

FEATURES

- * Low forward voltage drop
- * High current capability
- * High reliability
- * High surge current capability
- * Good for switching mode application

MECHANICAL DATA

- * Case: Molded plastic
- * Epoxy: UL 94V-0 rate flame retardant
- * Lead: Lead solderable per MIL-STD-202, method 208 guaranteed
- * Polarity: As Marked
- * Mounting position: Any

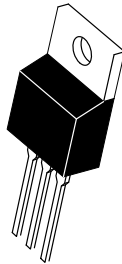

VOLTAGE RANGE

45 to 200 Volts

CURRENT

10.0 Amperes

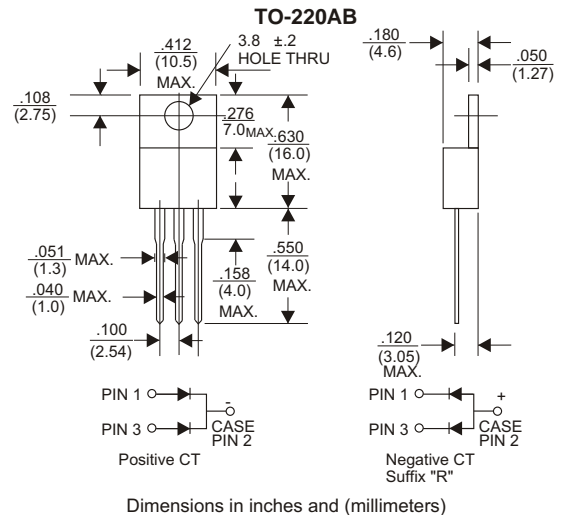

MAXIMUM RATINGS AND ELECTRICAL CHARACTERISTICS

Rating 25°C ambient temperature unless otherwise specified.
Single phase half wave, 60Hz, resistive or inductive load.
For capacitive load, derate current by 20%.

TYPE NUMBER	MBR10L45CT	MBR10L60CT	MBR10L100CT	MBR10L150CT	MBR10L200CT	UNITS
Maximum Recurrent Peak Reverse Voltage	45	60	100	150	200	V
Maximum RMS Voltage	45	60	100	150	200	V
Maximum DC Blocking Voltage	32	42	70	105	140	V
Maximum Average Forward Rectified Current						
at Tc=125°C	10					A
Peak Forward Surge Current, 8.3 ms single half sine-wave superimposed on rated load (JEDEC method)	150					A
Maximum Instantaneous Forward Voltage at 10A	0.46	0.55	0.7	0.85		V
Maximum DC Reverse Current	0.2					mA
at Rated DC Blocking Voltage	50					mA
Typical Junction Capacitance (Note1)	420					pF
Typical Thermal Resistance RθJC (Note 2)	2.5					°C/W
Operating Temperature Range Tj	-65 — +150					°C
Storage Temperature Range Tstg	-65 — +150					°C

NOTES:

1. Measured at 1MHz and applied reverse voltage of 4.0V D.C.
2. Thermal Resistance Junction to Case.

RATING AND CHARACTERISTIC CURVES (MBR10L45CT THRU MBR10L200CT)

FIG.1-TYPICAL FORWARD CURRENT DERATING CURVE

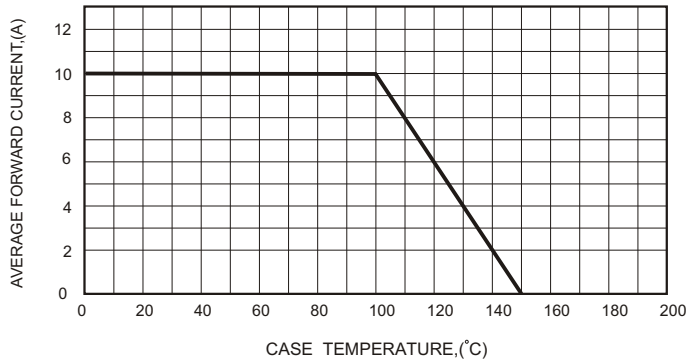

FIG.2-TYPICAL FORWARD CHARACTERISTICS

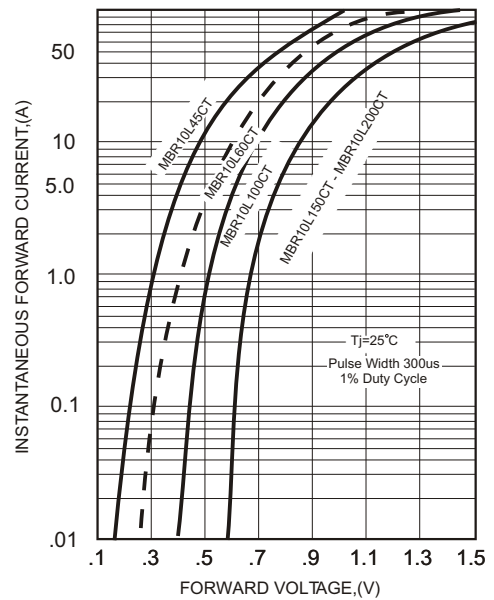

FIG.3 - TYPICAL REVERSE CHARACTERISTICS

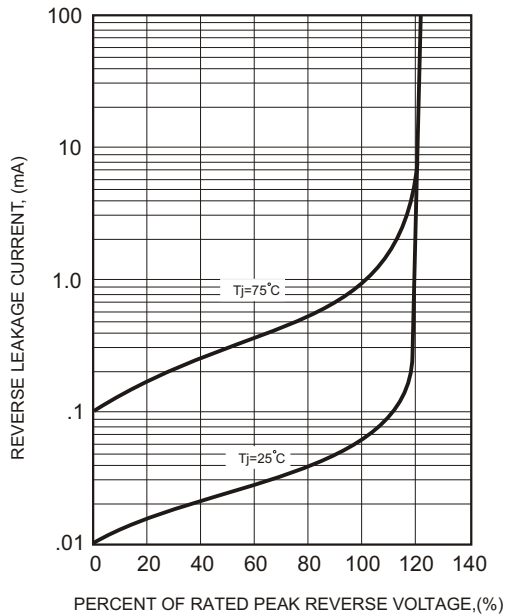

FIG.4-MAXIMUM NON-REPETITIVE FORWARD SURGE CURRENT

