

General Description

The EA8253 is a 3A buck regulator, designed to operate from 4.6V to 23V input voltage range. Built-in low $R_{DS(ON)}$ high/low side Power-MOSFETS not only reduce external components but also has up to 94% efficiency, ideal for 3A output current applications. The EA8253 is designed to take into account the light load mode operation. At output loading 20mA condition, the efficiency up to 81%. The EA8253 has complete protection functions, including cycle-by-cycle current limit, short circuit protection, OVP, OTP and UVLO protection. The EA8253 is available in the SOP-8 (with EP) package and has a good cooling effect and easy to use.

Features

- ▶ Built-in Low $R_{DS(ON)}$ Power-MOSFETS
- ▶ Efficiency Up to 94%
- ▶ Light Load Efficiency Up to 81%
- ▶ 4.6V to 23V Input Voltage Range
- ▶ Output Adjustable Down to 0.766V
- ▶ 3A Continuous Load Current
- ▶ Fixed 600KHz Switching Frequency
- ▶ Internal Compensation
- ▶ Cycle-by-Cycle Current Limit
- ▶ Short Circuit Protection
- ▶ Input UVLO Protection
- ▶ OTP Protection
- ▶ External Adjustable Soft-Start Function
- ▶ Available in SOP-8 (with EP) Package

Applications

- ▶ Distributed Power Systems
- ▶ Netcom Products
- ▶ LCD TVs and Flat TVs
- ▶ Notebooks



Pin Configurations

(TOP VIEW)

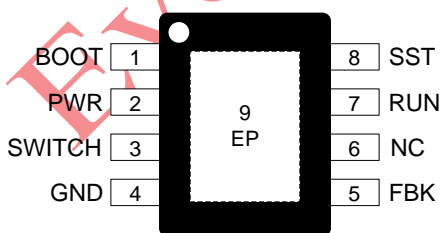

SOP-8 (with EP)

Pin Description

Pin Name	Function Description	Pin No.
BOOT	The power input of the internal high side N-MOSFET gate driver. Connect a 33nF ceramic capacitor from BOOT pin to SWITCH pin.	1
PWR	The EA8253 power input pin. Recommended to use two 10uF MLCC capacitors between PWR pin and GND pin.	2
SWITCH	Internal MOSFET switching output. Connect SWITCH pin with a low pass filter circuit to obtain a stable DC output voltage.	3
GND	Ground pin.	4
FBK	Feedback input. Connect FBK pin and GND pin with voltage dividing resistors to set the output voltage.	5
NC	Not Connect.	6
RUN	The device turns on/turns off control input. The EA8253 on/off state can be controlled by RUN pin voltage level. Connect RUN pin to PWR pin with a 150KΩ pull up resistor for automatic startup.	7
SST	Soft-Start input. Connect SST pin and GND pin by a ceramic capacitor. It can be used to set the soft-start time.	8
EP	Exposed Pad. Make sure that the EP has good soldering with the GND plane of the PCB surface to achieve the desired cooling effect.	9

Function Block Diagram

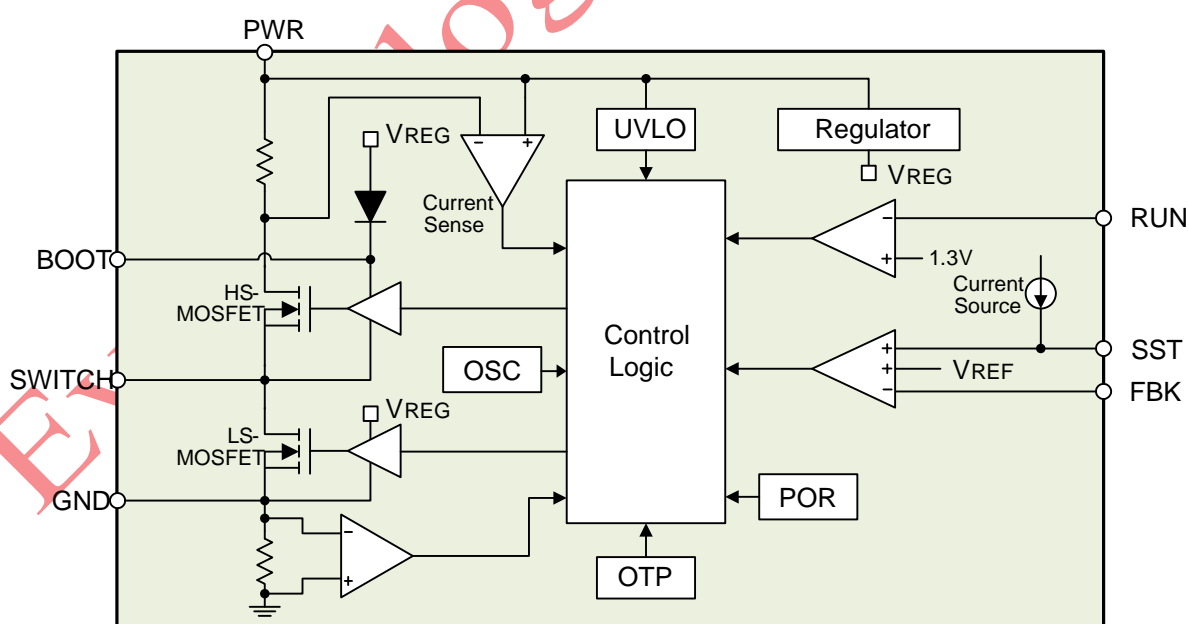

Figure 1. EA8253 internal function block diagram

Absolute Maximum Ratings

Parameter	Value
Input Voltage (V_{PWR})	-0.3V to +26V
RUN Pin Input Voltage (V_{RUN})	-0.3V to +26V
BOOT Pin Voltage (V_{BOOT})	$V_{SWITCH}-0.3V$ to $V_{SWITCH}+6.3V$
SWITCH Pin Voltage (V_{SWITCH})	-1V to +26V
FBK, SST Pins Voltage (V_{FBK} , V_{COMP} , V_{SST})	-0.3V to +6.3V
Ambient Temperature operating Range (T_A)	-40°C to +85°C
Maximum Junction Temperature (T_{Jmax})	+150°C
Lead Temperature (Soldering, 10 sec)	+260°C
Storage Temperature Range (T_S)	-65°C to +150°C

Note (1): Stresses beyond those listed under "Absolute Maximum Ratings" may cause permanent damage to the device. Exposure to "Absolute Maximum Ratings" conditions for extended periods may affect device reliability and lifetime.

Package Thermal Characteristics

Parameter	Value
SOP-8 (with EP) Thermal Resistance (θ_{JC})	14°C/W
SOP-8 (with EP) Thermal Resistance (θ_{JA})	65°C/W
SOP-8 (with EP) Power Dissipation at $T_A=25^\circ\text{C}$ (P_{Dmax})	1.92W

Note (1): P_{Dmax} is calculated according to the formula: $P_{Dmax}=(T_{JMAX}-T_A)/\theta_{JA}$.

Recommended Operating Conditions

Parameter	Value
Input Voltage (V_{PWR})	+4.5V to +23V
RUN Pin Input Voltage (V_{RUN})	-0.3V to +23V
Output Voltage (V_{OUT})	+0.766V to +19V
Junction Temperature Range (T_J)	-40°C to +125°C

Electrical Characteristics

$V_{PWR}=12V$, $T_A=25^{\circ}C$, unless otherwise noted

Parameter	Symbol	Test Conditions	Min	Typ	Max	Unit
Input Voltage	V_{PWR}		4.6		23	V
Shutdown Supply Current	I_{SD}	$V_{RUN} = 0V$		1	8	μA
Quiescent Current	I_Q	$V_{RUN} = 2V$, $V_{FBK} = 105\% V_{REF}$, $I_{LOAD} = 0A$		1.9		mA
UVLO Threshold	V_{UVLO}	V_{PWR} Rising	3.8	4.2	4.5	V
UVLO Hysteresis	$V_{UV-HYST}$			400		mV
Output Load Current	I_{LOAD}				3	A
Reference Voltage	V_{REF}	$4.6V \leq V_{PWR} \leq 20V$	0.75	0.766	0.782	V
Switching Frequency	F_{SW}		450	600	750	KHz
Short Frequency	F_{SHORT}	$V_{OUT} = 0V$		120		KHz
High Side MOSFET On-Resistance	$R_{DS(ON)-HM}$			125		m Ω
Low Side MOSFET On-Resistance	$R_{DS(ON)-LM}$			100		m Ω
High Side MOSFET Current Limit	I_{LIM-HM}		4.5	5		A
High Side MOSFET Leakage Current	$I_{LEAK-HM}$	$V_{RUN} = 0V$, $V_{SWITCH} = 0V$		1	10	μA
RUN Pin Input Low Voltage	V_{RUN-L}				0.4	V
RUN Pin Input High Voltage	V_{RUN-H}		2			V
Maximum Duty Cycle	D_{MAX}	$V_{FBK} = 0.6V$		88		%
High Side MOSFET Minimum On Time	T_{ONMIN}			120		ns
SST Pin Charge Current	I_{SST}	$V_{SST} = 0V$		6.5		μA
Thermal Shutdown Threshold	T_{OTP}			150		$^{\circ}C$
Thermal Shutdown Hysteresis	T_{HYST}			20		$^{\circ}C$

Note (1): MOSFET on-resistance specifications are guaranteed by correlation to wafer level measurements.

(2): Thermal shutdown specifications are guaranteed by correlation to the design and characteristics analysis.

Application Circuit Diagram

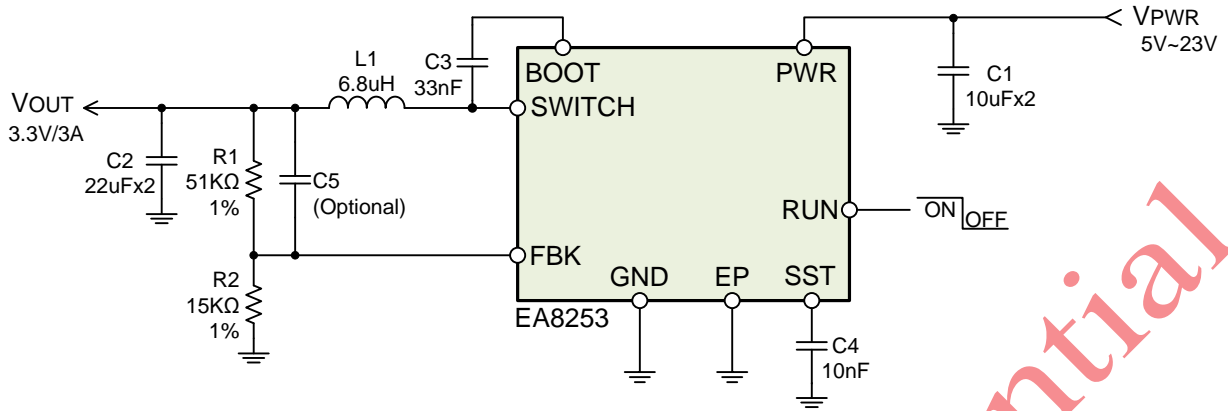

Figure 2. Typical application circuit diagram

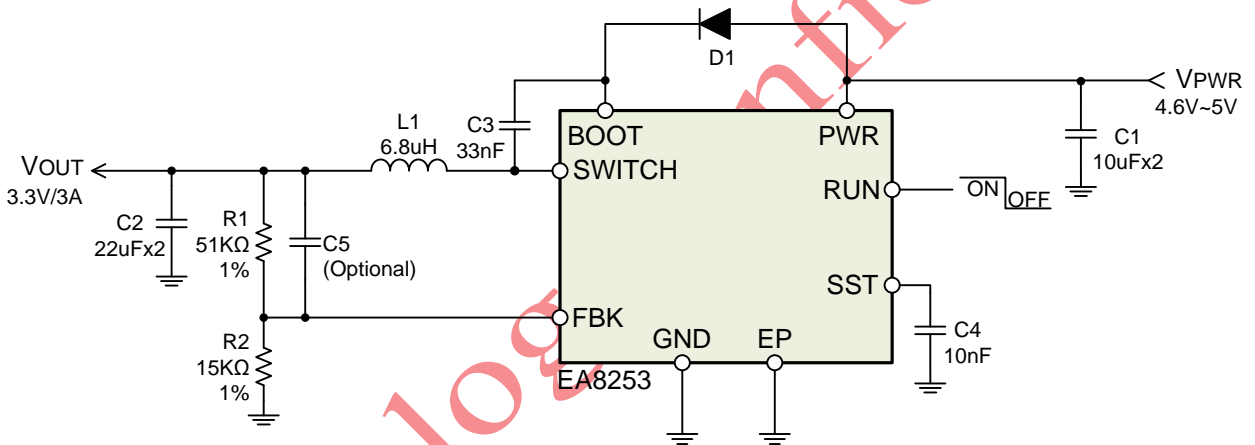

Figure 3. Recommended 5V application circuit diagram

Ordering Information

Part Number	Package Type	Packing Information
EA8253P8R	SOP-8(with EP)	Tape & Reel / 3000

Note (1): "P8": Package type code.
 (2): "R": Tape & Reel.

Application Information

Enable Control

The EA8253 use RUN pin to control the regulator turns on / turns off. When the RUN pin input voltage is higher than 2V, the EA8253 enters the operating mode. Drive the RUN pin input voltage lower than 0.4V to ensure the EA8253 into shutdown mode, as shown in Figure4. When the device works in the shutdown mode, the shutdown supply current is less than 1uA. The EA8253 also provides automatic startup function as shown in Figure 5. Connect RUN pin and PWR pin with a 150KΩ resistor, when the PWR supply input voltage increasing and higher than RUN pin threshold voltage, the EA8253 will enter operating mode automatically.

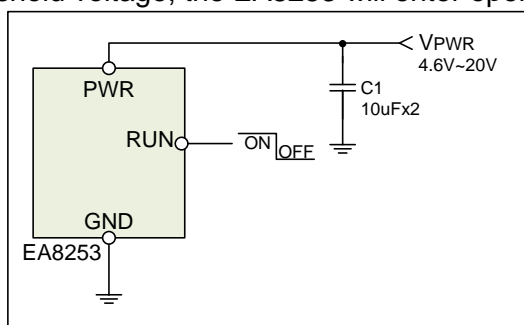

Figure 4. Enable control by RUN pin voltage

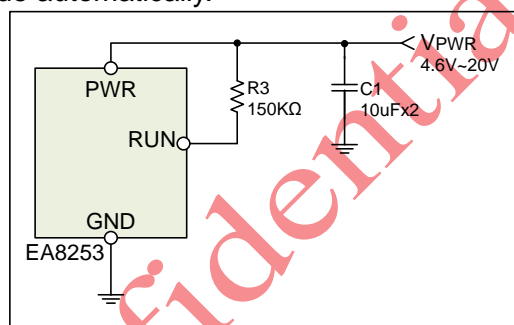

Figure 5. Automatic startup application circuit

Output Voltage Setting

The EA8253 output voltage can be set via a resistor divider (R1, R2). The output voltage is calculated by following equation:

$$V_{OUT} = 0.766 \times \frac{R1}{R2} + 0.766 \text{ V}$$

The following table lists common output voltage and the corresponding R1, R2 resistance value for reference.

Output Voltage	R1 Resistance	R2 Resistance	Tolerance
5V	100KΩ	18KΩ	1%
3.3V	51KΩ	15KΩ	1%
1.8V	21KΩ	15KΩ	1%
1.2V	9.1KΩ	15KΩ	1%
1V	4.7 KΩ	15KΩ	1%

Input / Output Capacitors Selection

The input capacitors are used to suppress the noise amplitude of the input voltage and provide a stable and clean DC input to the device. Because the ceramic capacitor has low ESR characteristic, so it is suitable for input capacitor use. It is recommended to use X5R or X7R MLCC capacitors in order to have better temperature performance and smaller capacitance tolerance. In order to suppress the output voltage ripple, the MLCC capacitor is also the best choice. The suggested part numbers of input / output capacitors are as follows:

Vendor	Part Number	Capacitance	Edc	Parameter	Size
TDK	C2012X5R1C106K	10uF	16V	X5R	0805
TDK	C3216X5R1E106K	10uF	25V	X5R	1206
TDK	C2012X5R0J226K	22uF	6.3V	X5R	0805
TDK	C3216X5R1A226M	22uF	10V	X5R	1206

Output Inductor Selection

The output inductor selection mainly depends on the amount of ripple current through the inductor ΔI_L . Large ΔI_L will cause larger output voltage ripple and loss, but the user can use a smaller inductor to save cost and space. On the contrary, the larger inductance can get smaller ΔI_L and thus the smaller output voltage ripple and loss. But it will increase the space and the cost. The inductor value can be calculated as:

$$L = \frac{V_{PWR} - V_{OUT}}{\Delta I_L \times F_{SW}} \times \frac{V_{OUT}}{V_{PWR}}$$

For most applications, 4.7H to 15uH inductors are suitable for EA8253. The suggested part numbers of output inductors are as follows:

Vendor	Part Number	Inductance	DCR (Max.)	Saturation Current	Dimensions (mm) (WxLxH)
SUMIDA	CDRH8D43R-6R8	6.8uH	29.8mΩ	4.2A	8.3x8.5x4.5
SUMIDA	CDRH104R-100	10uH	35.6 mΩ	3.9A	10.3x10.5x4

External bootstrap Diode Selection

For input 4.6V to 5V applications, it is recommended to add an external bootstrap diode between PWR pin and BOOT pin when the duty ratio is higher than 65%. The bootstrap diode can be a low cost one such as 1N4148. It's important that the external boot voltage must be lower than 5.5V.

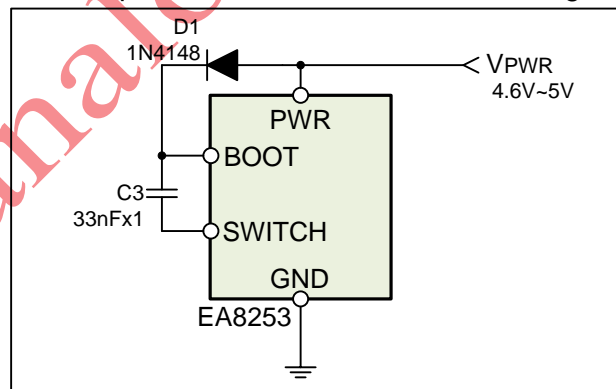

Figure 6. Bootstrap diode application circuit

PCB Layout Recommendations

For EA8253 PCB layout considerations, please refer to the following suggestions in order to get good performance.

- ▶ High current path traces (shown as Figure 7.) need to be widened.
- ▶ Place the input capacitors as close as possible to the PWR pin to reduce noise interference.
- ▶ Keep the feedback path (from V_{OUT} to FBK) away from the noise node (ex. SWITCH).

- SWITCH is a high current noise node. Complete the layout by using short and wide traces.

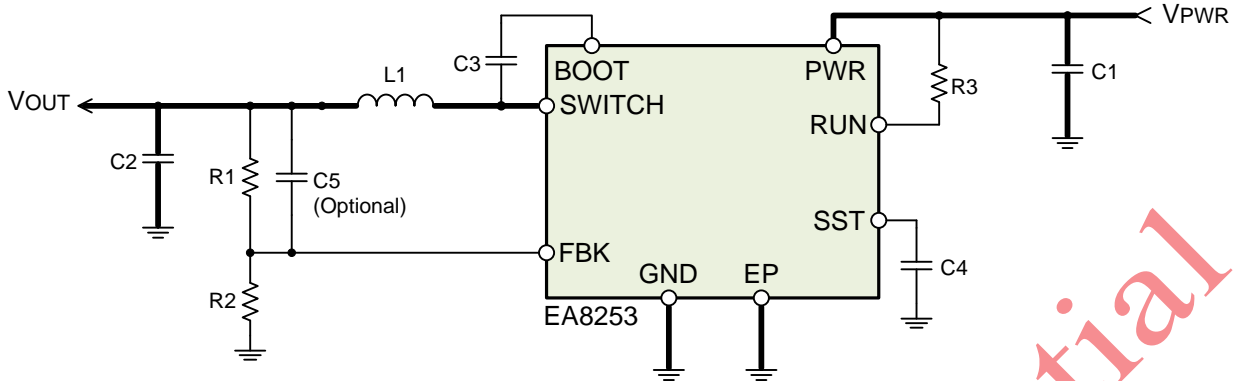

* Bold lines indicate high current paths

Figure 7. Recommended layout diagram

Package Information

SOP-8(with EP) Package

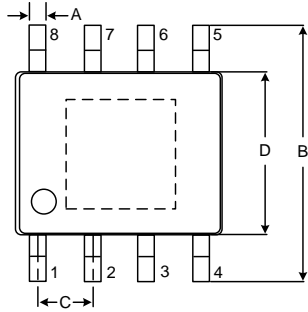

Top View

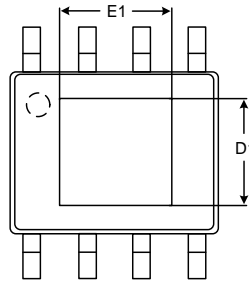

Bottom View



Front View

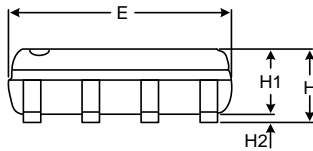

Side View

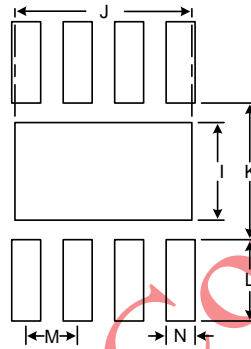

Recommended Layout Pattern

Unit: mm

Symbol	Dimension		Symbol	Dimension
	Min	Max		Typ
A	0.32	0.52	I	2.40
B	5.79	6.20	J	4.90
D	3.79	4.00	K	3.80
D1	2.16	2.42	L	2.00
E	4.81	5.01	M	1.27
E1	3.05	3.51	N	0.72
C	1.19	1.35		
F	0.41	1.27		
G	0.17	0.25		
H	1.26	1.71		
H1	1.26	1.56		
H2	0.00	0.15		