

承認書

SPECIFICATION FOR APPROVAL

CUSTOMER: _____ 2144 _____

DESCRIPTION: _____ COMMON MODE CHOKE _____

DDY PART NO: _____ WBA0603D900PT-F-HF _____

CUSTOMERMODELNO: _____

DRAWING		
MADE	CHECKED	APPROVED
谭晶晶	黄志伟	肖中华
DATE:	2023年7月6日	

CUSTOMER APPROVE

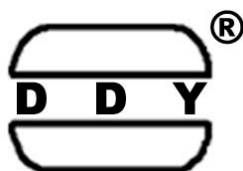

惠州市德立电子有限公司
HUI ZHOU DE LI ELECTRONICS CO., LTD

廣東省博羅縣洲際工業園梅園三路
NO.3 MEI YUAN ROAD, ZHOU JI INDUSTRIAL AREA, BOLUO COUNTY GUANGDONG

電話: 15970768093 13640935893

傳真: 0752-6207969

郵編: 516100

Http://ddycoils.com



惠州市德立电子有限公司

HUI ZHOU DE LI ELECTRONICS CO., LTD

CUSTOMER:	2144	REV NO:	A
DESCRIPTION:	COMMON MODE CHOKE	PAGE NO:	PAGE 1 OF 6
PART NO:	WBA0603D900PT-F-HF	SN.	
CUSTOMER NO:		DATE:	2023年7月6日

CATALOG

Resume	P2
Shape & Dimension	P3
Characteristic	P3
Part numbering ststem	P3
General specification	P3
Soldering Conditions	P4
Material List	P4
Package Information	P5
Electrical Characteristic Curve	P6



惠州市德立电子有限公司

HUI ZHOU DE LI ELECTRONICS CO., LTD

CUSTOMER:	2144	REV NO:	A
DESCRIPTION:	COMMON MODE CHOKE	PAGE NO:	PAGE 3 OF 6
PART NO:	WBA0603D900PT-F-HF	SN.	
CUSTOMER NO:		DATE:	2023年7月6日

1.SHAPE & DIMENSION

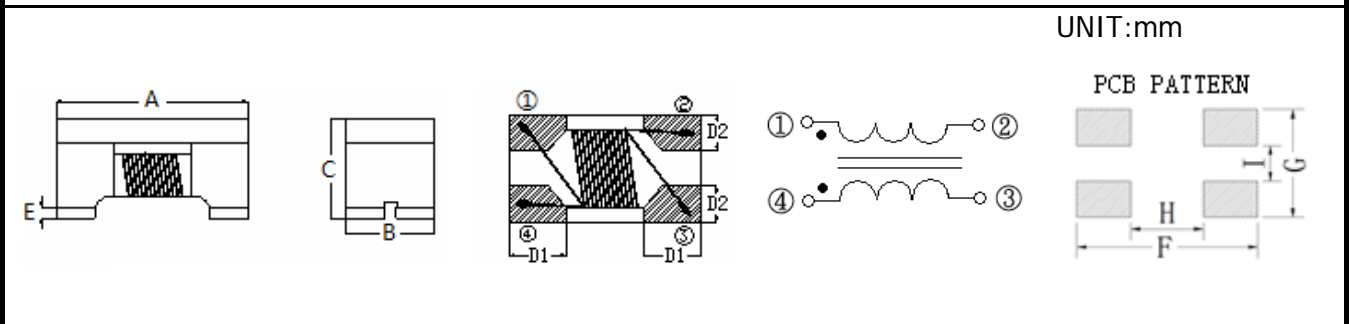

CODE	A	B	C	E	D1	D2	F	G	H	I
DIMENSION	1.6±0.1	0.8±0.1	1.1±0.1	0.1 Max	0.33 Typ.	0.25 Typ.	1.89 Typ.	0.85 Typ.	0.73 Typ.	0.25 Typ.

2. ELECTRICAL CHARACTERISTICS @25°C

Part Number	Z	Freq	Rdc	Irms	Rated Voltage	Insulation Resistance
	(Ω)	(MHz)	(Ω)max	(mA)max	Volts	MΩ Min
WBA0603D900PT-F-HF	90	100	0.25	300	20	10

3. PART NUMBERING SYSTEM

WBA	□□□□	□	□□□	□	□	—	□□
1	2	3	4	5	6		7

- 1 PRODUCT SYMBOL (产品代号)
- 2 DIMENSIONS (规格尺寸)
- 3 TYPE (类型)
- 4 IMPEDANCE (阻抗)
- 5 TOLERANCE (公差) : P±25%; N±30%
- 6 PACKAGING (包装方式) : T-编带盘装; B-散装
- 7 E.P. (环保) : LF—Lead Free HF—Halogen Free FP—Red Phosphor Free

4.GENERAL SPECIFICATION

- a. Rating DC current: Temperature rise(ΔT) is 40°C approximately at Irms.
- b. Operating temp.: -40°C~ +85°C
- c. Storage temp.: -10°C ~ +40°C R.H.: 65% Max
- d. Moisture sensitivity level (MSL) 2 (1 year floor life at <30°C/65% relative humidity)

APPROVED BY	CHECKED BY	DRAFT
肖中华	黄志伟	谭晶晶

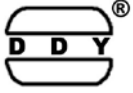

惠州市德立电子有限公司

HUI ZHOU DE LI ELECTRONICS CO., LTD

CUSTOMER:	2144	REV NO:	A
DESCRIPTION:	COMMON MODE CHOKE	PAGE NO:	PAGE 4 OF 6
PART NO:	WBA0603D900PT-F-HF	SN.	
CUSTOMER NO:		DATE:	2023年7月6日

5. SOLDERING CONDITIONS

**Figure 1.
Re-flow
Soldering (Lead
Free)**

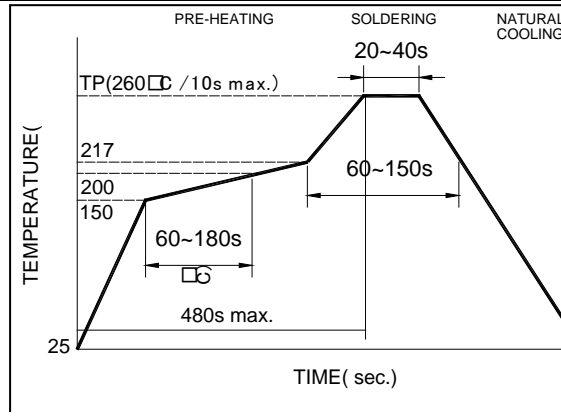

Note:

- Preheat circuit and products to 150°C
- 260°C tip temperature (max)
- Reflow times: no more than 2 times
- Solder paste thickness: the best 0.08mm is ,but max is 0.1mm

**Figure 2.
Hand Soldering**

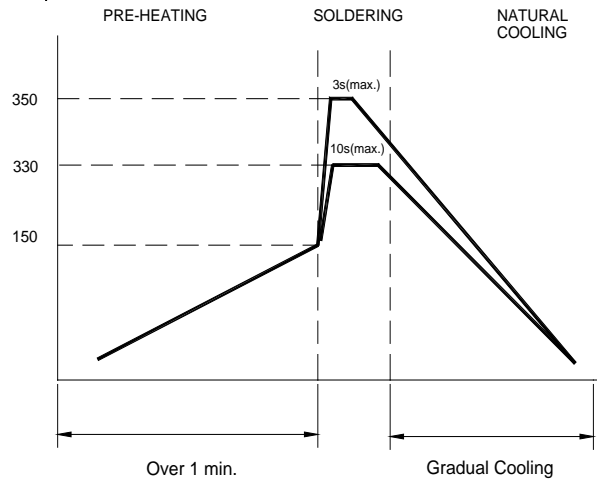

Note:

- Use a 20 watt soldering iron with tip diameter of 1.0mm
- Limit soldering time to 3 sec.

6.MATERIAL LIST

NO	DESCRIPTION	DESCRIPTION	SUPPLIER	
1	Upper Plate	Ferrite	Flag Magnetic Or equivalent	
2	Core	Ferrite Core	Flag Magnetic Or equivalent	
3	Wire	Enameled Copper Wire	Elektrisola Or equivalent	

REMARK:

APPROVED BY	CHECKED BY	DRAWN BY
肖中华	黄志伟	谭晶晶



惠州市德立电子有限公司

HUI ZHOU DE LI ELECTRONICS CO., LTD

CUSTOMER:	2144	REV NO:	A
DESCRIPTION:	COMMON MODE CHOKE	PAGE NO:	PAGE 5 OF 6
PART NO:	WBA0603D900PT-F-HF	SN.	
CUSTOMER NO:		DATE:	2023年7月6日

7. PACKAGING(unit: mm)

Type	0603
Quantity	3000

TAPING DRAWINGS

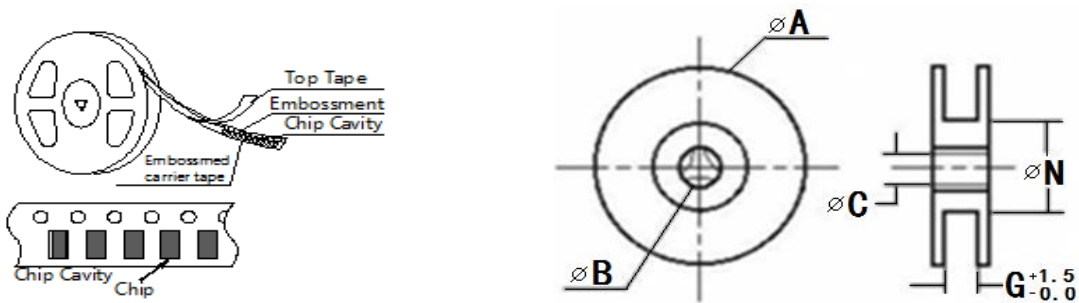

REEL DIMENSIONS(UNIT:mm)

	A	B	C	N	G
CF-8	178±2.0	22±2.0	12.5±1.5	57±2.0	8

LEADER AND BLANK PORTION

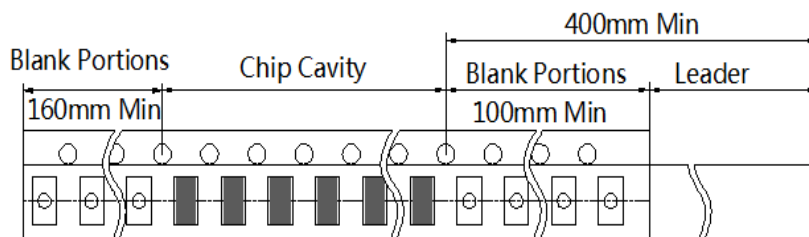

PEELLING OFF FORCE:0.05 to 0.7N in the direction show below.

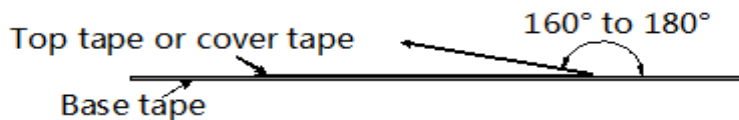

注意:

此物料不涉及汽车或相关产品方面的应用，否则，由此引起的一切品质和责任问题，我司将概不承担。

APPROVED BY	CHECKED BY	DRAFT
肖中华	黄志伟	谭晶晶

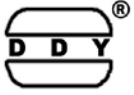

CUSTOMER:	2144	REV NO:	A
DESCRIPTION:	COMMON MODE CHOKE	PAGE NO:	PAGE 6 OF 6
PART NO:	WBA0603D900PT-F-HF	SN.	
CUSTOMER NO:		DATE:	2023年7月6日

8.ELECTRICAL CHARACTERISTIC CURVE

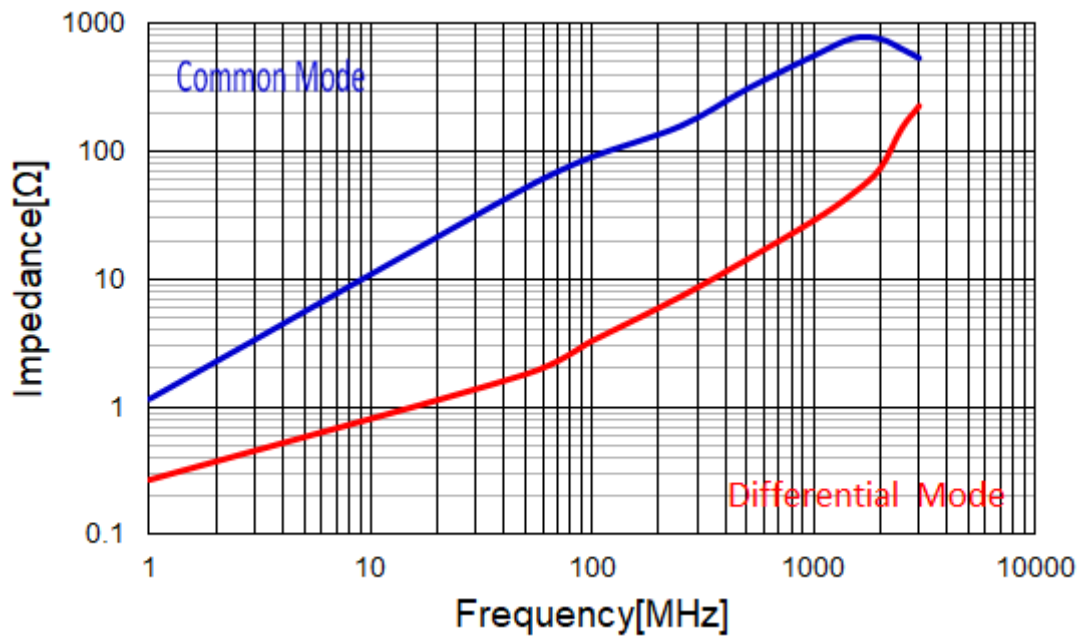

APPROVED BY	CHECKED BY	DRAFT
肖中华	黄志伟	谭晶晶