

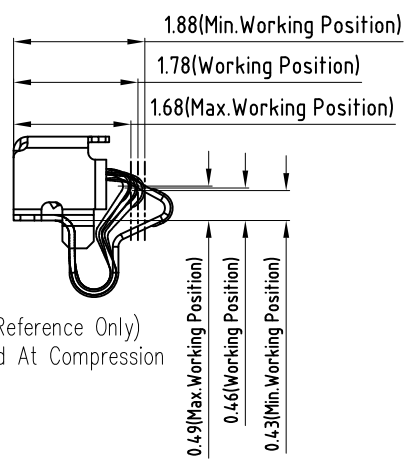

3D View

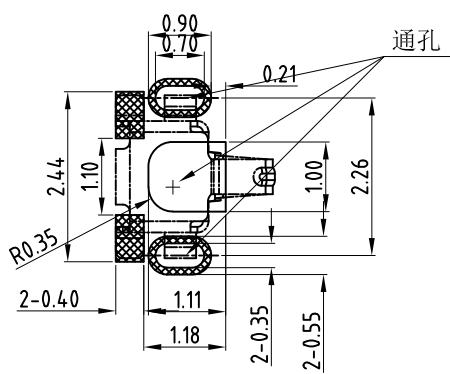
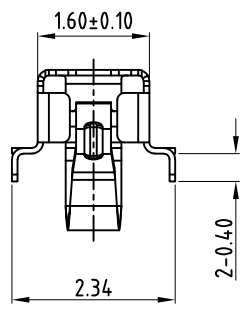
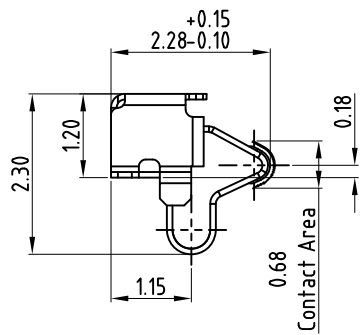
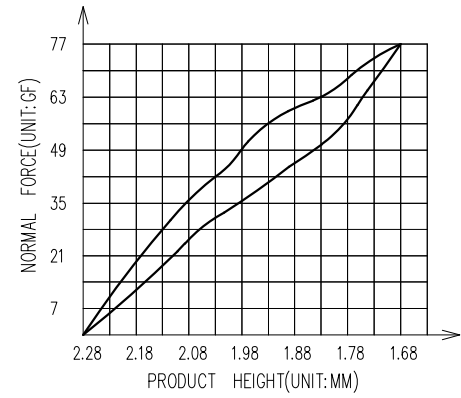

(For Reference Only)
Stated At Compression

- NOTES:
- 1: MATERIAL
1-1: C5210 THICKNE=0.08MM
 - 2: SPECIFICATIONS
2-1: RATED CURRENT: 1.0A
2-2: VOLTAGE RATING: 1.5V
2-3: CONTACT RESISTANCE: 80mΩ/MAX
2-4: WELDING THRUST: ≥3KG
2-5: OPERATING TEMPERATURE: -40°C~+85°C
 - 3: DURABILITY: 1500 CYCLES
 - 4: SALT SPRAY TIME: 24H
 - 5: ELECTROPLATE: THE NICKEL-PLATED SUBSTRATE IS 50μ" MIN
 - 6: REQUIREMENTS
6-1: TERMINAL TO EAT FULL TIN, NOT PEELING, WELDING OBVIOUS COLOR AND OTHER ADVERSE
6-2: ROHS, REACH, HF HALOGER ADVERSE OF DOMESTIC AND INTERNATIONAL ENVIRONMENTAL REQUIREMENTS

RECOMMENDED PCB LAYOUT
TOLERANCE: ±0.05MM (FOR REFERENCE ONLY)

 深圳市华宇创精密电子有限公司			
TOLERANCE: X.X ±0.30 X.XX ±0.25 X.XXX ±0.15 X' ±2' X.X' ±0.5'	DRAWN BY : 陈一鸣	DATE : 2014-02-23	PART NAME: 天线弹片 L2.28*W2.34*H2.3
	CHECKED BY: 马跃	DATE : 2014-02-23	PART NO. HYCW-TXT22823423A
UNIT: mm [inch] SCALE: 1:1 SIZE: A4	APPROVED BY: 邱敏	DATE : 2014-02-23	DRAW NO: HYC-2406071445
			SHEET NO. 1 OF 1