

RECOMMENDED PCB LAYOUT
TOLERANCE±0.05(焊盘推荐图)

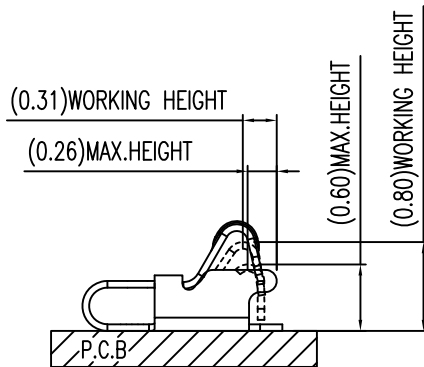

STATED AT COMPRESSION
(FOR REFERENCE ONLY)

NOTES

- (1)MATERIAL:SUS-301 THICKNE=0.06mm
- (2)PRODUCT SPECIFICATIONS:
 - 2-1:RATED CURRENT: 1.0A
 - 2-2:VOLTAGE RATING: 1.50V
 - 2-3:CONTACT RESISTANCE: 80mΩ/MAX
 - 2-4:WELDING THRUST: ≥ 3KG
 - 2-5:OPERATING TEMPERATURE: -40°C~+85°C
 - 2-6:DURABILITY: 1500 CYCLES
- (3):SALT SPRAY: 24 HOURS
- (4):FINISH:50u"Min NICKEL UNDERPLATING OVER ALL.
- (5):REQUIREMENTS
 - 5-1:TERMINAL TO EAT FULL TIN,NOTPEELING WELDING OBVIOUS COLOR AND OTHER ADVERSE
 - 5-2:ROHS,REACH,HF HALOGER ADVERSE OF DOMESTIC AND INTERNATIONAL ENVIRONMENTAL REQUIREMENTS



深圳市华宇创精密电子有限公司

TOLERANCE: X.X ±0.30 X.XX ±0.25 X.XXX ±0.15 X' ±2' X.X' ±0.5'	DRAWN BY : 陈一鸣	DATE : 2014-02-23	PART NAME: 天线弹片 L1. 80*W1. 0*H1. 0
	CHECKED BY: 马跃	DATE : 2014-02-23	PART NO. HVCW-TXT181010A
UNIT: mm [inch] SCALE:1:1 SIZE: A4	APPROVED BY: 邱敏	DATE : 2014-02-23	DRAW NO: HVC-2406061124
			SHEET NO. 1 OF 1