

# 承認書

## SPECIFICATION FOR APPROVAL

CUSTOMER: \_\_\_\_\_ 2144 \_\_\_\_\_

DESCRIPTION: \_\_\_\_\_ COMMON MODE CHOKE \_\_\_\_\_

DDY PART NO: \_\_\_\_\_ WBA0603D220PT-F-HF \_\_\_\_\_

CUSTOMERMODELNO: \_\_\_\_\_

DRAWING		
MADE	CHECKED	APPROVED
譚晶晶	黃志偉	肖中華
DATE:	2023年7月20日	

CUSTOMER APPROVE

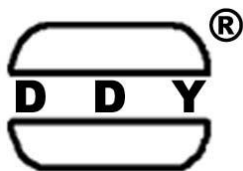

惠州市德立电子有限公司  
HUI ZHOU DE LI ELECTRONICS CO., LTD

廣東省博羅縣洲際工業園梅園三路  
NO.3 MEI YUAN ROAD,ZHOU JI INDUSTRIAL AREA,BOLUO COUNTY GUANGDONG

電話：15970768093 13640935893

傳真：0752-6207969

郵編：516100

Http://ddycoils.com

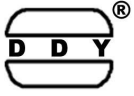

惠州市德立电子有限公司

HUI ZHOU DE LI ELECTRONICS CO., LTD

CUSTOMER:	2144	REV NO:	A
DESCRIPTION:	COMMON MODE CHOKE	PAGE NO:	PAGE 1 OF 5
PART NO:	WBA0603D220PT-F-HF	SN.	
CUSTOMER NO:		DATE:	2023年7月20日

## CATALOG

Resume	.....	P2
Shape & Dimension	.....	P3
Characteristic	.....	P3
Part numbering stsem	.....	P3
General specification	.....	P3
Soldering Conditions	.....	P4
Material List	.....	P4
Package Information	.....	P5



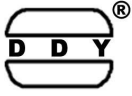

# 惠州市德立电子有限公司

## HUI ZHOU DE LI ELECTRONICS CO., LTD

CUSTOMER:	2144	REV NO:	A
DESCRIPTION:	COMMON MODE CHOKE	PAGE NO:	PAGE 3 OF 5
PART NO:	WBA0603D220PT-F-HF	SN.	
CUSTOMER NO:		DATE:	2023年7月20日

### 1. SHAPE & DIMENSION

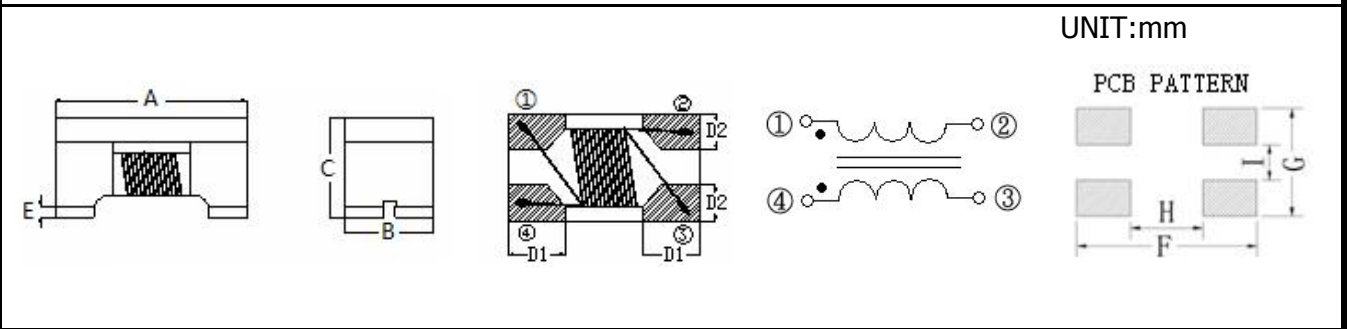

CODE	A	B	C	E	D1	D2	F	G	H	I
DIMENSION	1.6±0.1	0.8±0.1	1.1±0.1	0.1 Max	0.33 Typ.	0.25 Typ.	1.89 Typ.	0.85 Typ.	0.73 Typ.	0.25 Typ.

### 2. ELECTRICAL CHARACTERISTICS @25°C

Part Number	Z	Freq	Rdc	Irms	Rated Voltage	Insulation Resistance
	(Ω)	(MHz)	(Ω)max	(mA)max	Volts	MΩ Min
WBA0603D220PT-F-HF	22	100	0.11	500	20	10

### 3. PART NUMBERING SYSTEM

<b>WBA</b>	□□□□	□	□□□	□	□	—	□□
<b>1</b>	<b>2</b>	<b>3</b>	<b>4</b>	<b>5</b>	<b>6</b>		<b>7</b>

- PRODUCT SYMBOL (产品代号)
- DIMENSIONS (规格尺寸)
- TYPE (类型)
- IMPEDANCE (阻抗)
- TOLERANCE (公差) : P±25%; N±30%
- PACKAGING (包装方式) : T-编带盘装; B-散装
- E.P. (环保) : LF—Lead Free HF—Halogen Free FP—Red Phosphor Free

### 4. GENERAL SPECIFICATION

- a. Rating DC current: Temperature rise(ΔT) is 40°C approximately at Irms.
- b. Operating temp.: -40°C~ +85°C
- c. Storage temp.: -10°C ~ +40°C R.H.: 65% Max
- d. Moisture sensitivity level (MSL) 2 (1 year floor life at <30°C/65% relative humidity)

APPROVED BY	CHECKED BY	DRAFT
肖中华	黄志伟	谭晶晶

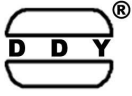

**惠州市德立电子有限公司**  
**HUI ZHOU DE LI ELECTRONICS CO., LTD**

CUSTOMER:	2144	REV NO:	A
DESCRIPTION:	COMMON MODE CHOKE	PAGE NO:	PAGE 4 OF 5
PART NO:	WBA0603D220PT-F-HF	SN.	
CUSTOMER NO:		DATE:	2023年7月20日

**5. SOLDERING CONDITIONS**

**Figure 1.  
Re-flow  
Soldering (Lead  
Free)**

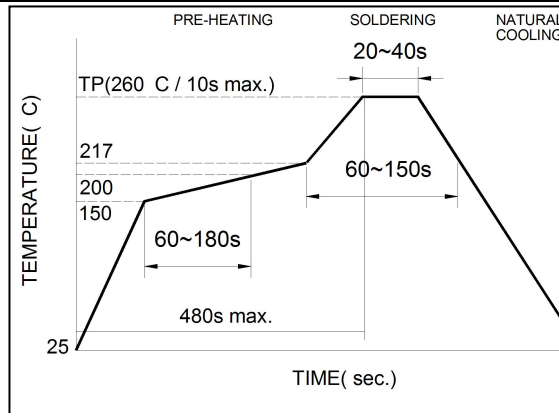

**Note:**

- Preheat circuit and products to 150°C
- 260°C tip temperature (max)
- Reflow times: no more than 2 times
- Solder paste thickness: the best 0.08mm is ,but max is 0.1mm

**Figure 2.  
Hand Soldering**

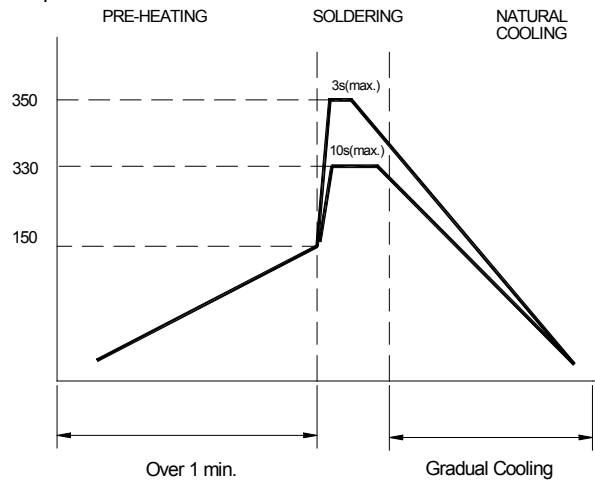

**Note:**

- Use a 20 watt soldering iron with tip diameter of 1.0mm
- Limit soldering time to 3 sec.

**6.MATERIAL LIST**

NO	DESCRIPTION	DESCRIPTION	SUPPLIER	
1	Upper Plate	Ferrite	Flag Magnetic Or equivalent	
2	Core	Ferrite Core	Flag Magnetic Or equivalent	
3	Wire	Enameled Copper Wire	Elektrisola Or equivalent	

REMARK:

APPROVED BY	CHECKED BY	DRAWN BY
肖中华	黄志伟	谭晶晶

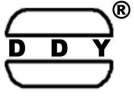

惠州市德立电子有限公司

HUI ZHOU DE LI ELECTRONICS CO., LTD

CUSTOMER:	2144	REV NO:	A
DESCRIPTION:	COMMON MODE CHOKE	PAGE NO:	PAGE 5 OF 5
PART NO:	WBA0603D220PT-F-HF	SN.	
CUSTOMER NO:		DATE:	2023年7月20日

**7. PACKAGING(unit: mm)**

Type	0603
Quantity	3000

**TAPING DRAWINGS**

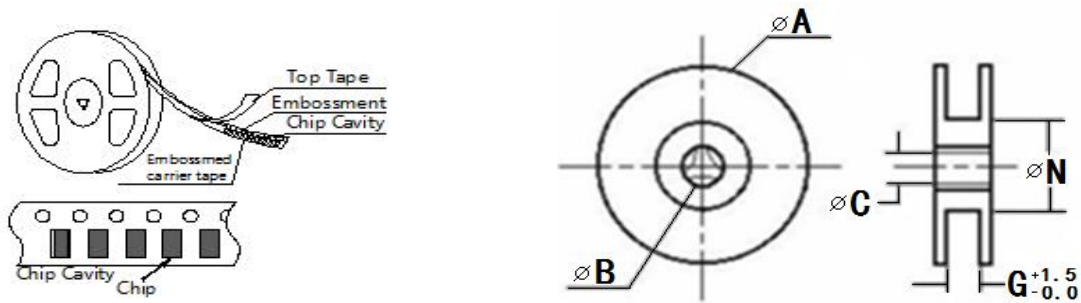

**REEL DIMENSIONS(UNIT:mm)**

	A	B	C	N	G
CF-8	178±2.0	22±2.0	12.5±1.5	57±2.0	8

**LEADER AND BLANK PORTION**

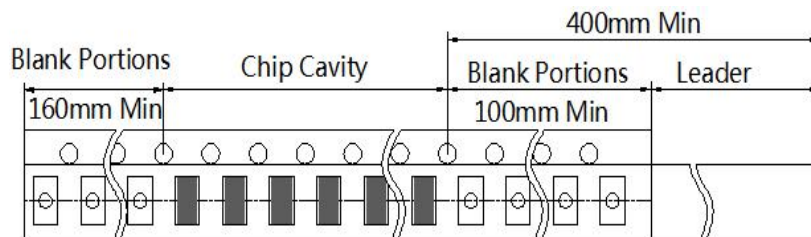

**PEELLING OFF FORCE:0.05 to 0.7N in the direction show below.**

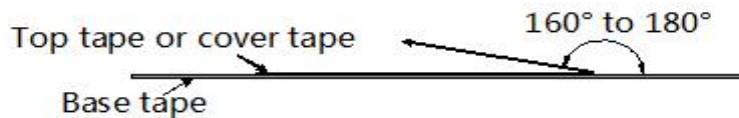

**注意:**

此物料不涉及汽车或相关产品方面的应用，否则，由此引起的一切品质和责任问题，我司将概不承担。

APPROVED BY	CHECKED BY	DRAFT
肖中华	黄志伟	谭晶晶