

SAW Duplexer

for B66 / Unbalanced / LR / 1612

Pinnacle PN: SA6616121G74AT

Key Feature:

✓ Band 66 Support

✓ Low Insertion Loss

1 Description

SA6616121G74AT is a high-performance Surface Acoustic Wave (SAW) duplexer optimized for FDD LTE Band 66 applications operating in the range of 1.710-1.780GHz / 2.110-2.200 GHz. It is designed to provide low insertion loss in Band 66, good isolation between TX and RX ports, and high rejection in the adjacent cellular bands for mobile devices.

SA6616121G74AT uses advanced Chip Scale Package (CSP) technology and is housed in an industry-standard, 8-pin 1.6mm x 1.2 mm package with a low profile of 0.6 mm max.

2 Package & Dimensions:

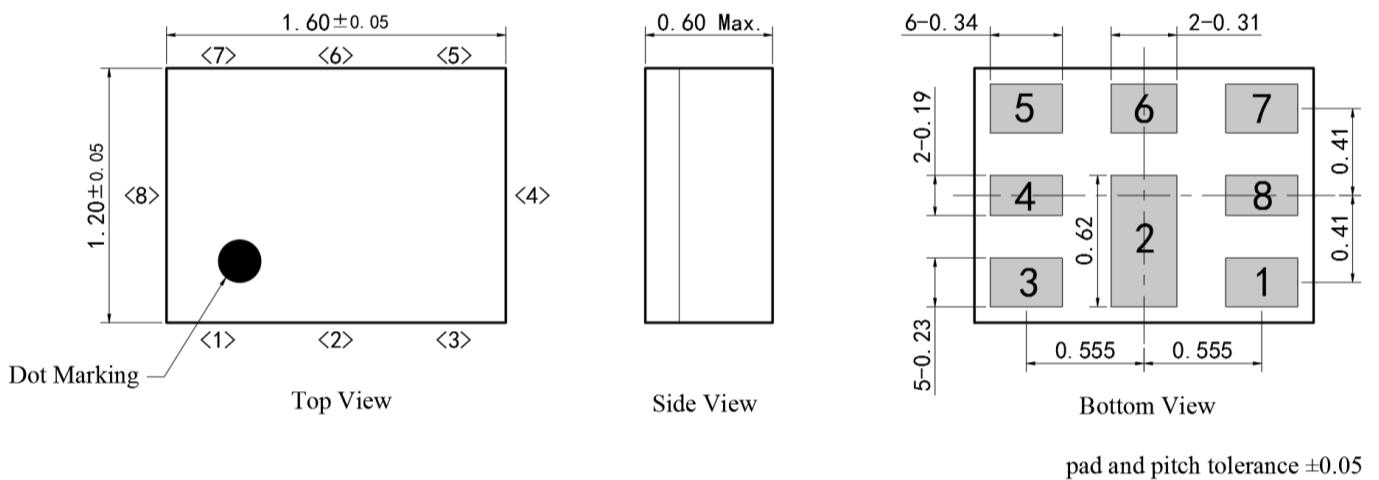

Figure 1: Drawing of Package with each tolerance range

3 Test Circuit

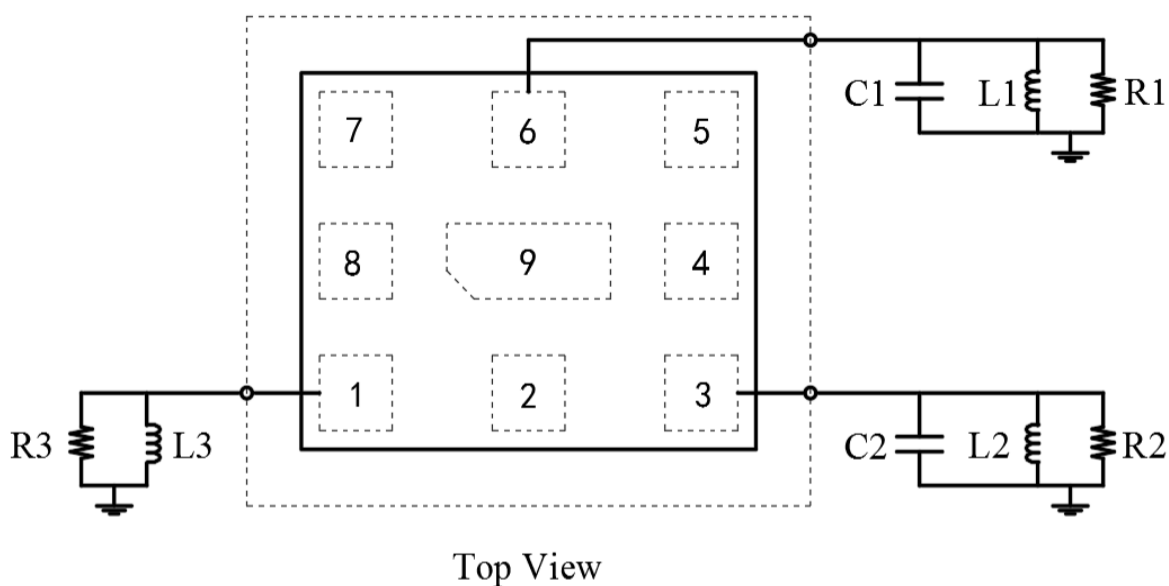

Figure 2: Schematic of matching circuit. External matching components required as below.

R1: 50 Ohm	L1: 2.7 nH C1: 0.5 pF
R2: 50 Ohm	L2: 4.7 nH C2: 0.5 pF
R3: 50 Ohm	L3: 5.6 nH

4 Pin configuration

- 1 RX
- 3 TX
- 6 Ant
- 2, 4, 5,7,8 To be grounded

5 Absolute Maximum Ratings

Parameter	Rating	Unit
Operating Temperature	-30 to +85	°C
Storage Temperature	-40 to +85	°C
Input Power@ input port	Pin=31dBm Continuous wave for 5000h@+55 °C	dBm
Approximate weight	3	mg
Moisture Sensitivity Levels	3	MSL
Maximum DC Voltage	3	V

6 Recommended Soldering Profile

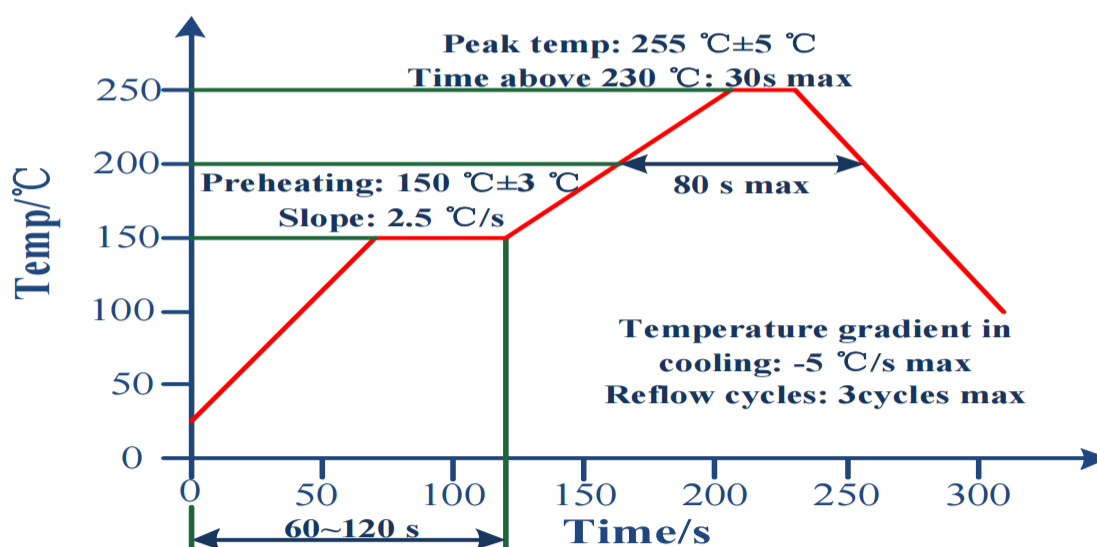

Figure 3: Recommended Reflow profile for convection and infrared soldering-lead-free solder.

7 Electrical Specifications

(At $T_a=25^{\circ}\text{C}$, unless otherwise specified, as measured on the evaluation board of SA6616121G74AT with feed line loss de-embedded.)

TX→ANT					
Parameter	Conditions	Min	Typ.	Max	Unit
Insertion Loss	1710 - 1780 MHz	-	1.9	2.5	dB
Passband Ripple	1710 - 1780 MHz	-	0.8	1.4	dB
Attenuation	10 - 728 MHz	48	53	-	dB
	699 - 716 MHz	45	50	-	dB
	704 - 716 MHz	45	52	-	dB
	777 - 787 MHz	40	51	-	dB
	824 - 849 MHz	40	50	-	dB
	851 - 894 MHz	40	50	-	dB
	1226 - 1250 MHz	38	42	-	dB
	1559 - 1563 MHz	35	42	-	dB
	1556.42 - 1573.37 MHz	35	42	-	dB
	1573.37 - 1577.47 MHz	38	45	-	dB
	1577.47 - 1585.42 MHz	40	45	-	dB
	1597.55 - 1605.89 MHz	38	43	-	dB
	1805 - 1880 MHz	8	15	-	dB
	2110 - 2200 MHz	40	45	-	dB
	2350 - 2360 MHz	35	40	-	dB
	2400 - 2500 MHz	35	40	-	dB
2500 - 2570 MHz	35	40	-	dB	
VSWR(TX)	1710 - 1780 MHz	-	1.5	2.0	-
VSWR(ANT)	1710 - 1780 MHz	-	1.4	1.9	-

ANT→RX						
Parameter	Conditions	Min	Typ.	Max	Unit	
Insertion Loss	2110 - 2200 MHz	-	1.9	2.5	dB	
Passband Ripple	2110 - 2200 MHz	-	1.5	1.8	dB	
Attenuation	10 - 1710 MHz	35	40	-	dB	
	699 - 716 MHz	45	52	-	dB	
	777 - 787 MHz	45	52	-	dB	
	814 - 849 MHz	42	48		dB	
	1710 - 1780 MHz	40	45		dB	
	2400 - 2500 MHz	37	42		dB	
	2496 - 2690 MHz	35	40		dB	
	2500 - 2570 MHz	35	40		dB	
	3820 - 3910 MHz	30	35		dB	
	4220 - 4310 MHz	30	36		dB	
VSWR(ANT)	2110 - 2200 MHz	-	1.8	2.2	-	
VSWR(RX)	2110 - 2200 MHz	-	1.8	2.2	-	

TX→RX					
Parameter	Conditions	Min	Typ.	Max	Unit
Isolation	1574 -1577 MHz	51	53	-	dB
	1710 - 1780 MHz	50	52	-	dB
	2110 - 2200 MHz	51	52	-	dB
	3410 - 3570 MHz	35	38	-	dB

8 Frequency Characteristics

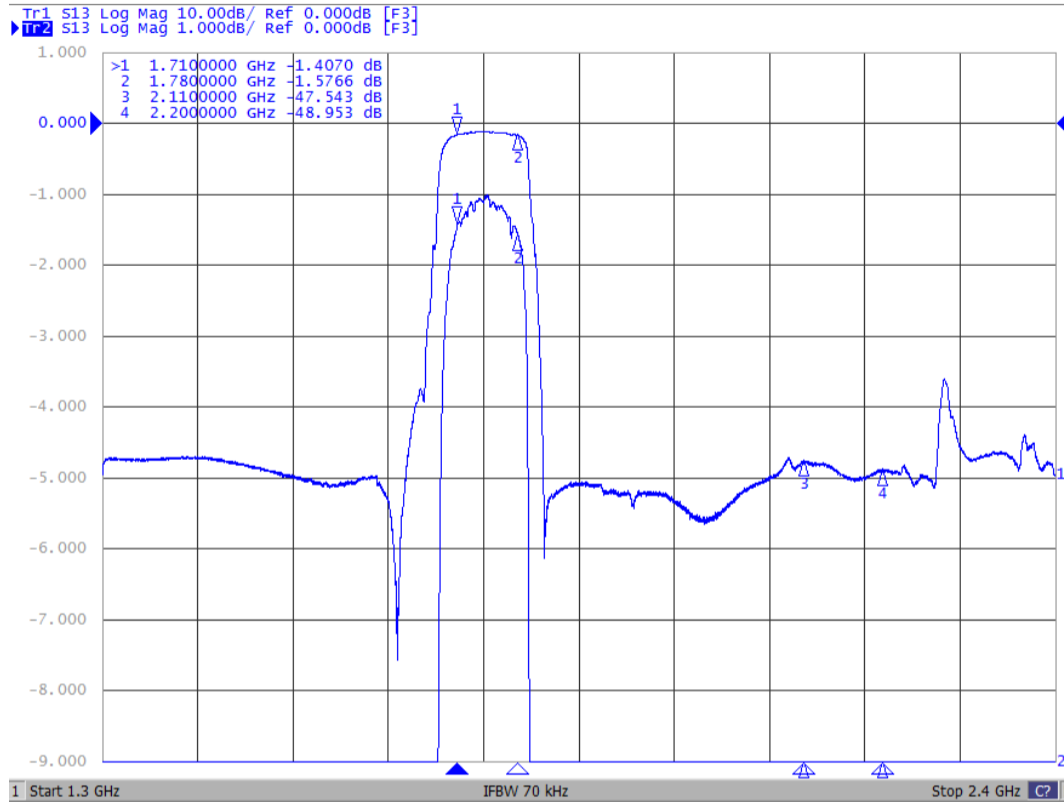

Figure 4: TX→ANT

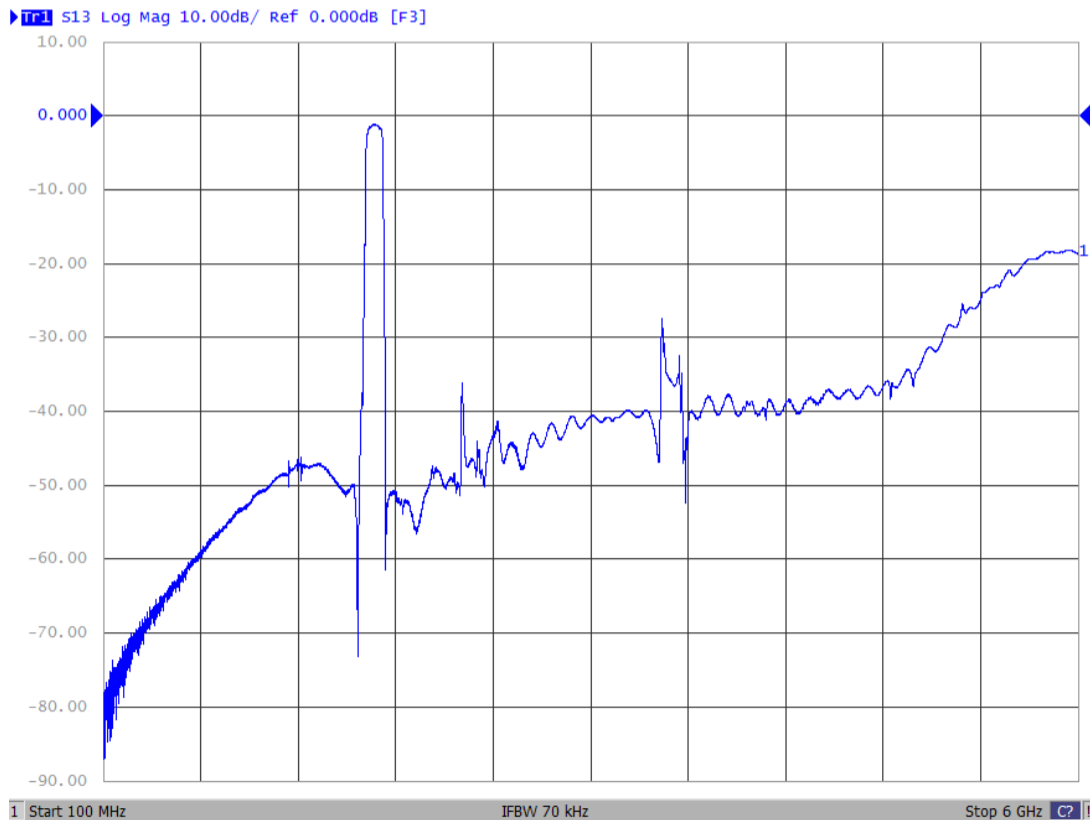

Figure 5: TX→ANT (Wide Band)

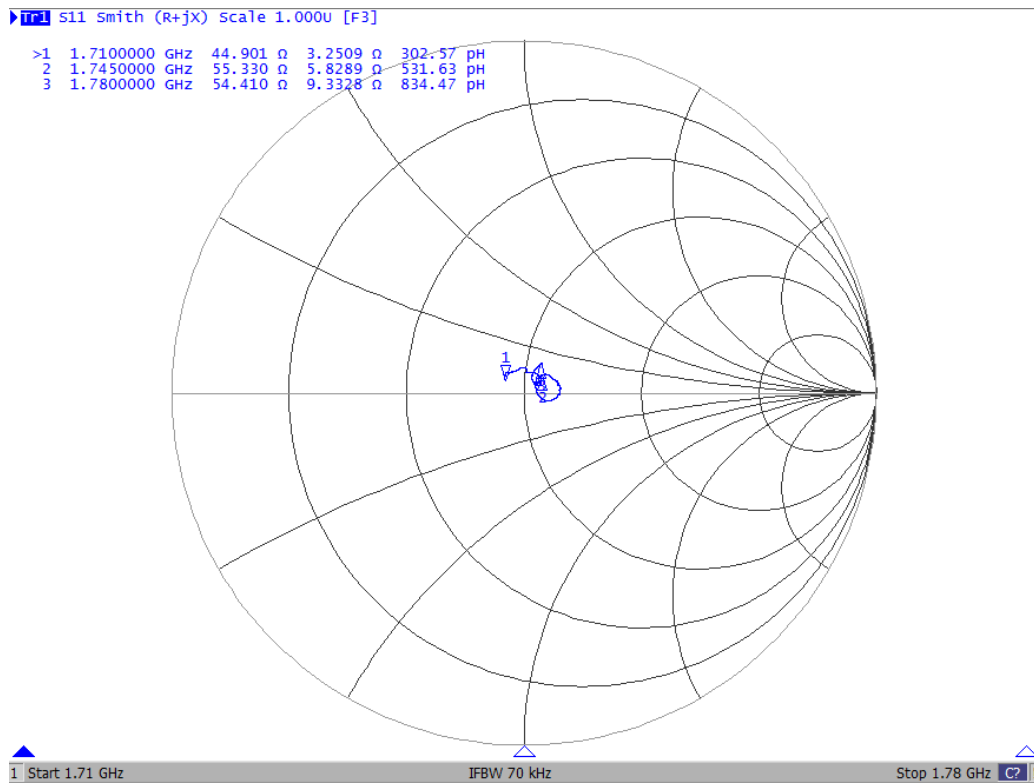

Figure 6: Smith for ANT

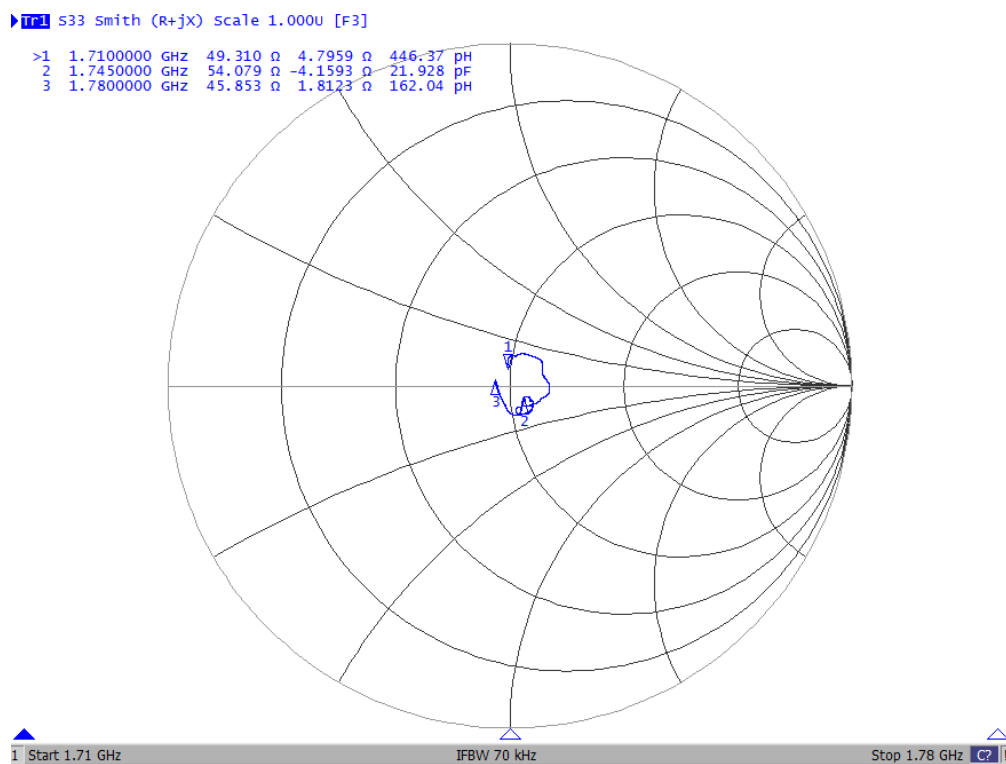

Figure 7: Smith for TX

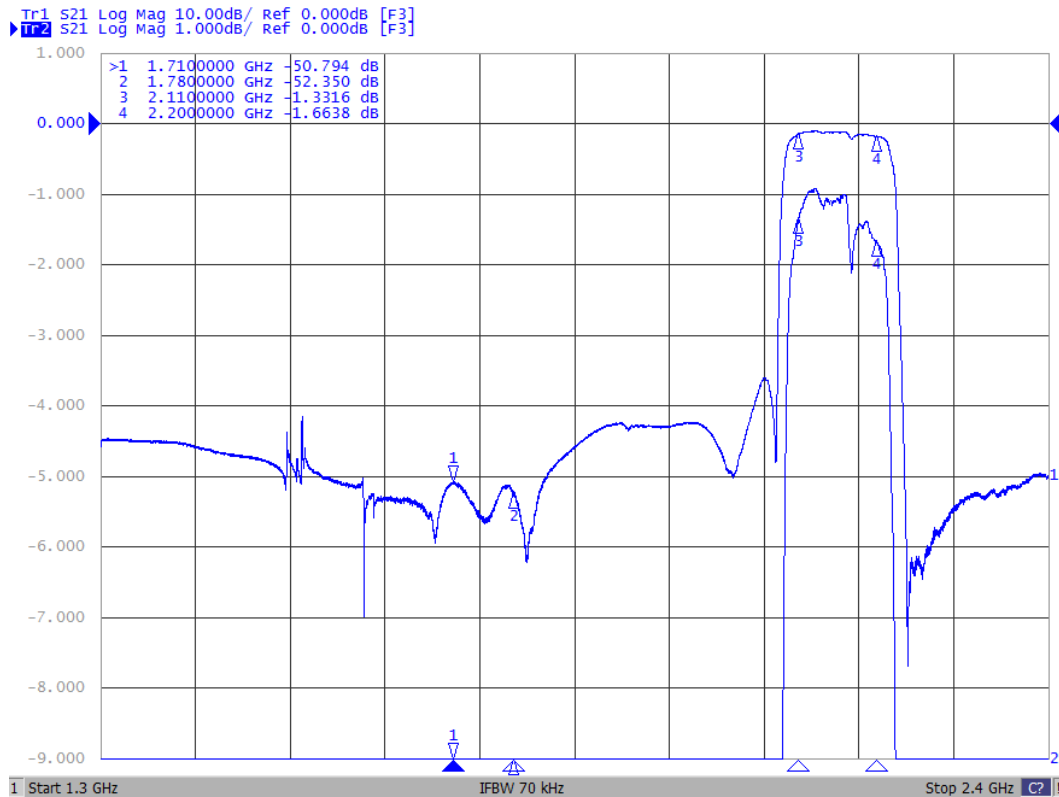

Figure 8: ANT→RX

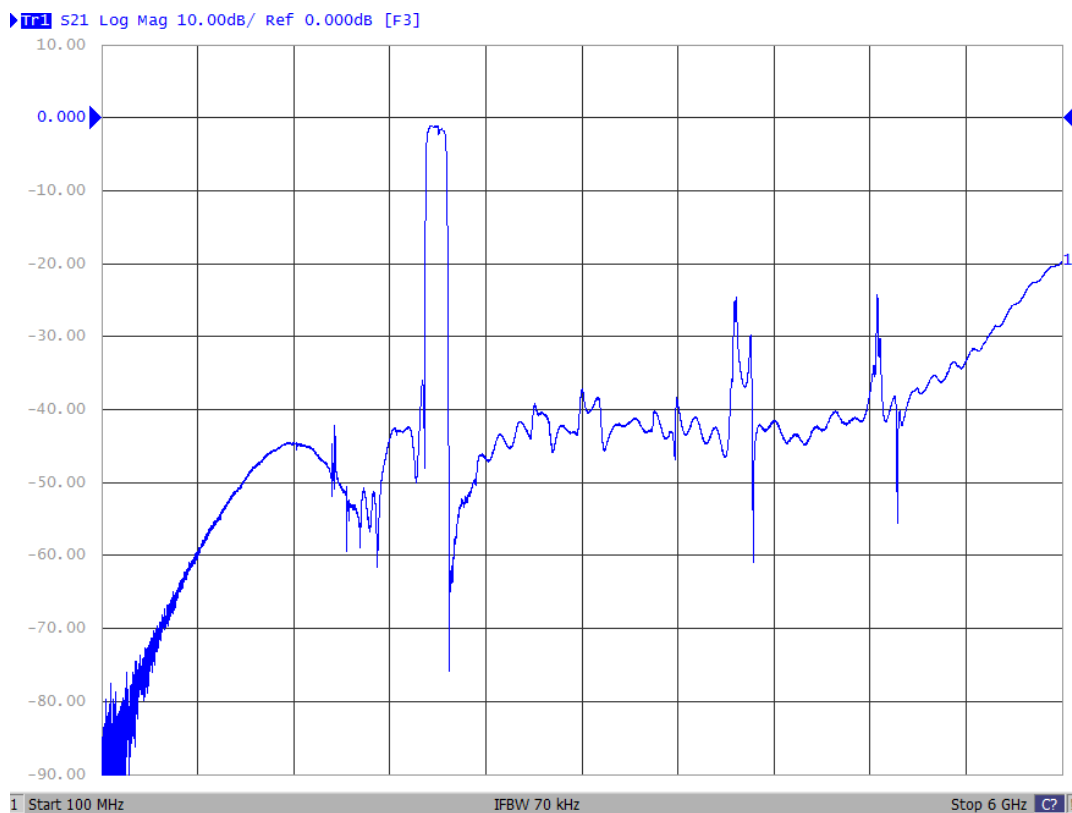

Figure 9: ANT→RX (Wide Band)

▶ S11 Smith (R+jX) Scale 1.000u [F3]

>1	2.1100000	GHZ	63.276	Ω	6.9106	Ω	521.26	pH
2	2.1550000	GHZ	43.012	Ω	-426.93	p Ω	172.99	pF
3	2.2000000	GHZ	48.072	Ω	6.4784	Ω	468.67	pH

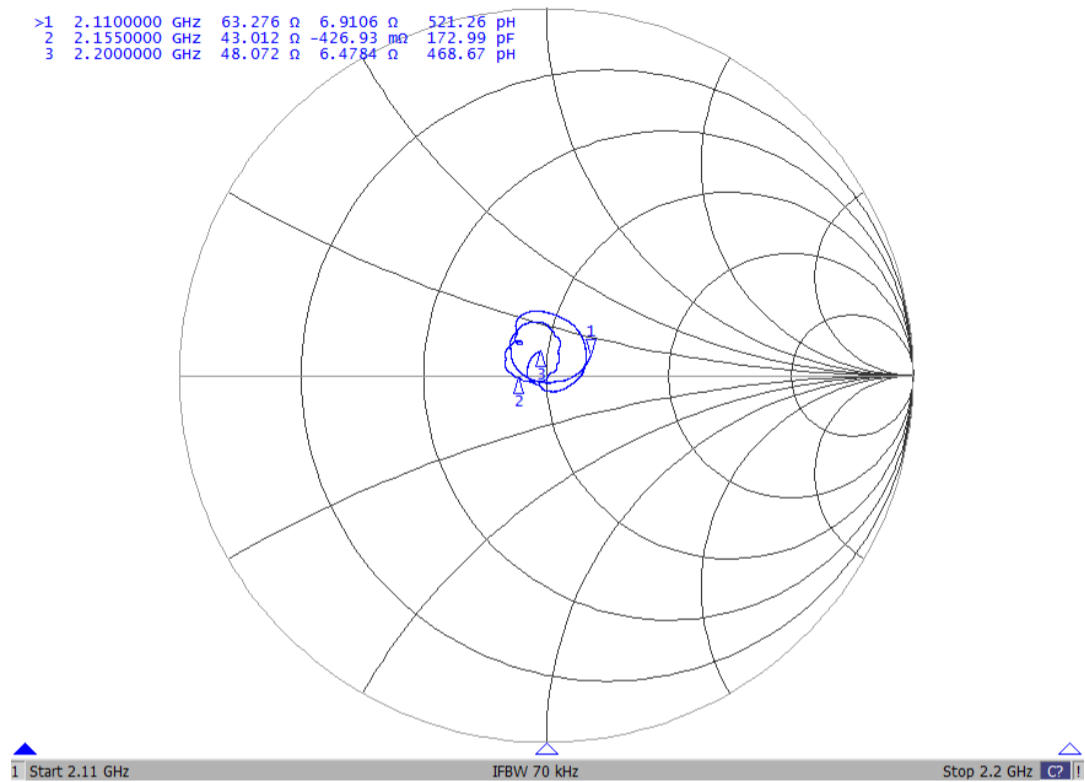

Figure 10: Smith for ANT

▶ S22 Smith (R+jX) Scale 1.000u [F3]

>1	2.1100000	GHZ	59.016	Ω	-7.1379	Ω	10.567	pF
2	2.1550000	GHZ	42.278	Ω	4.0261	Ω	297.34	pH
3	2.2000000	GHZ	56.902	Ω	6.0793	Ω	439.79	pH

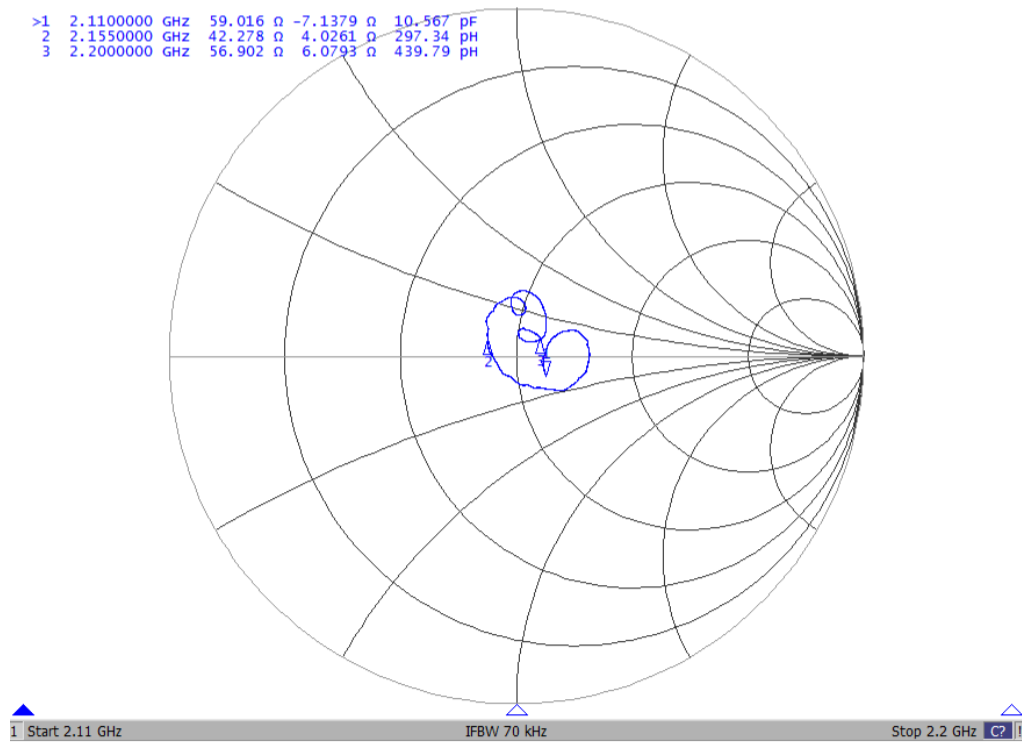

Figure 11: Smith for RX

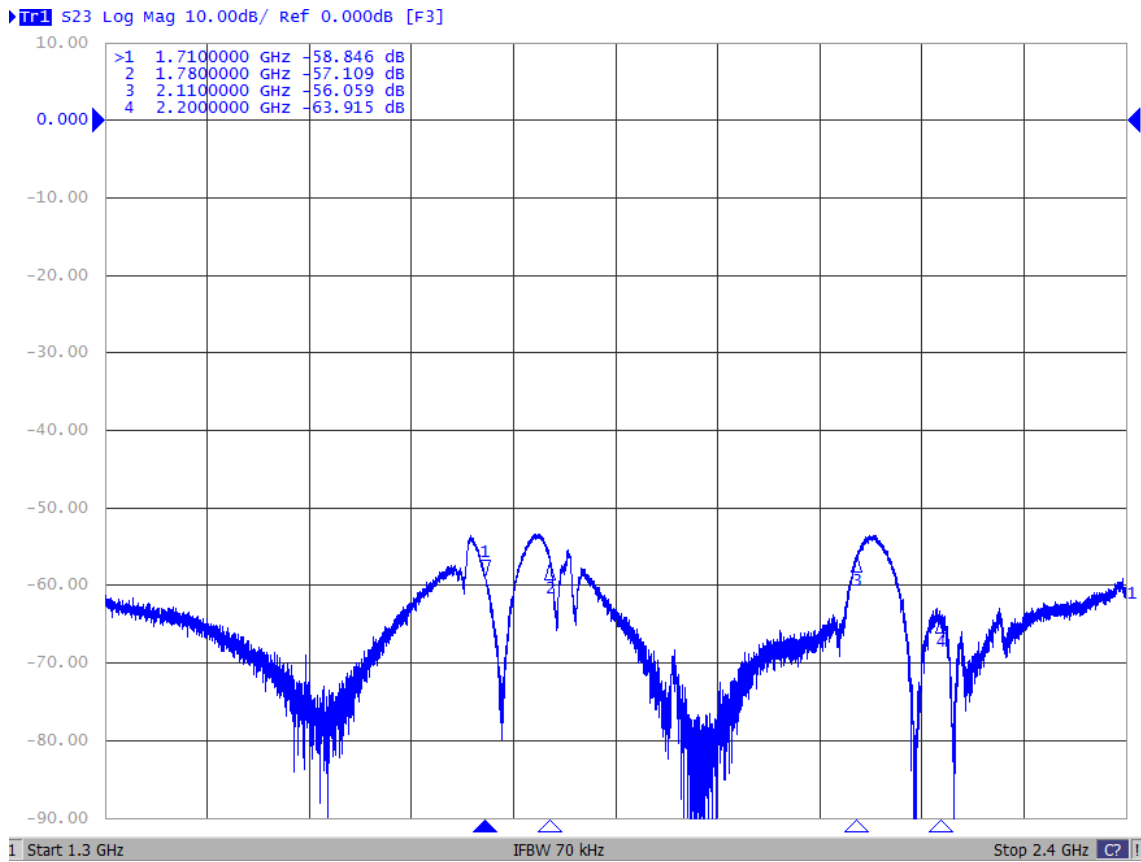

Figure 12: TX→RX

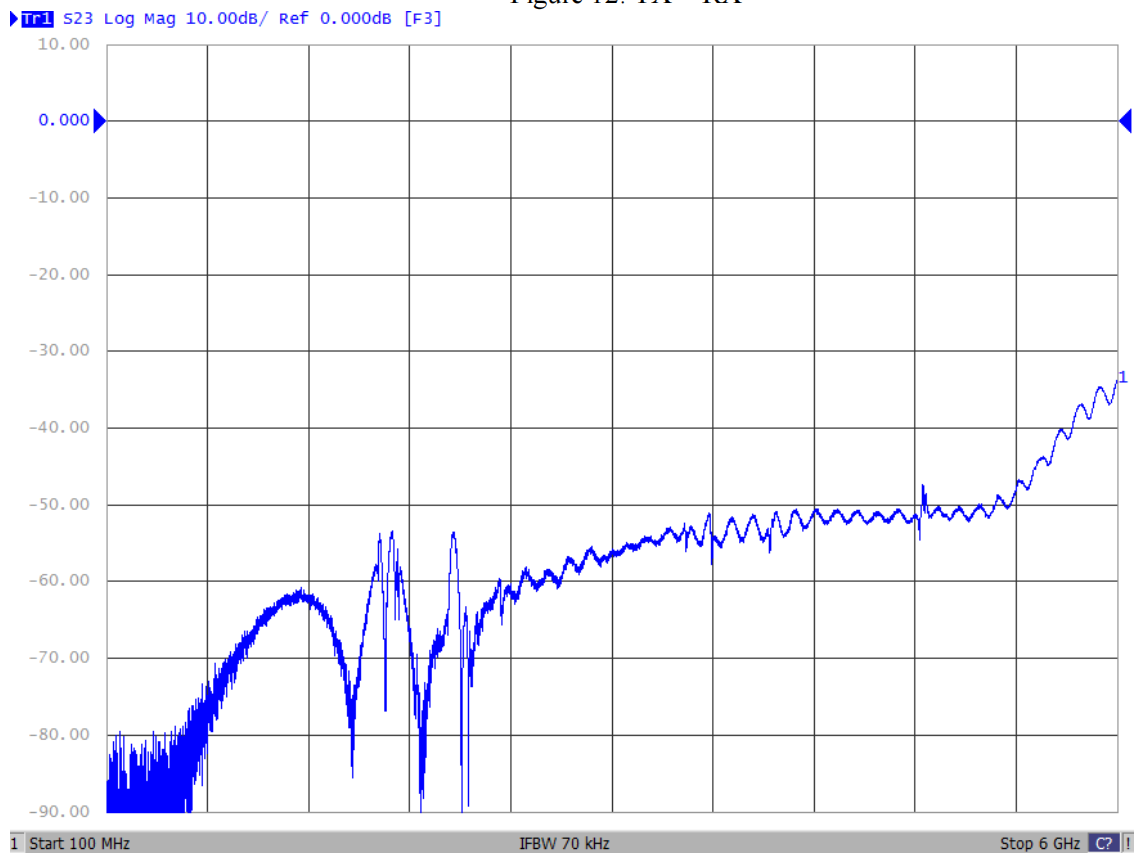

Figure 13: TX→RX (Wide Band)

9 Packaging

9.1 Tape

Tensile Strength of Carrier Tape: Carrier tape 10N or more; Cover tape 5N or more. Packaging quantities: 5000 PCS / Reel.

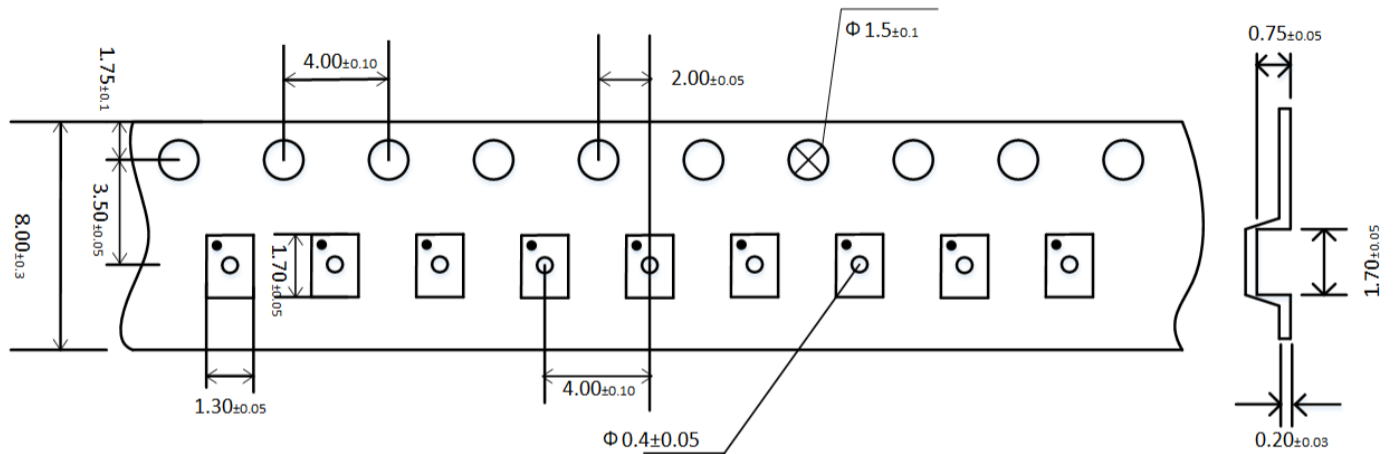

Figure 14: Drawing of tape with tape dimensions according above (mm).

9.2 Reel with diameter of 178mm

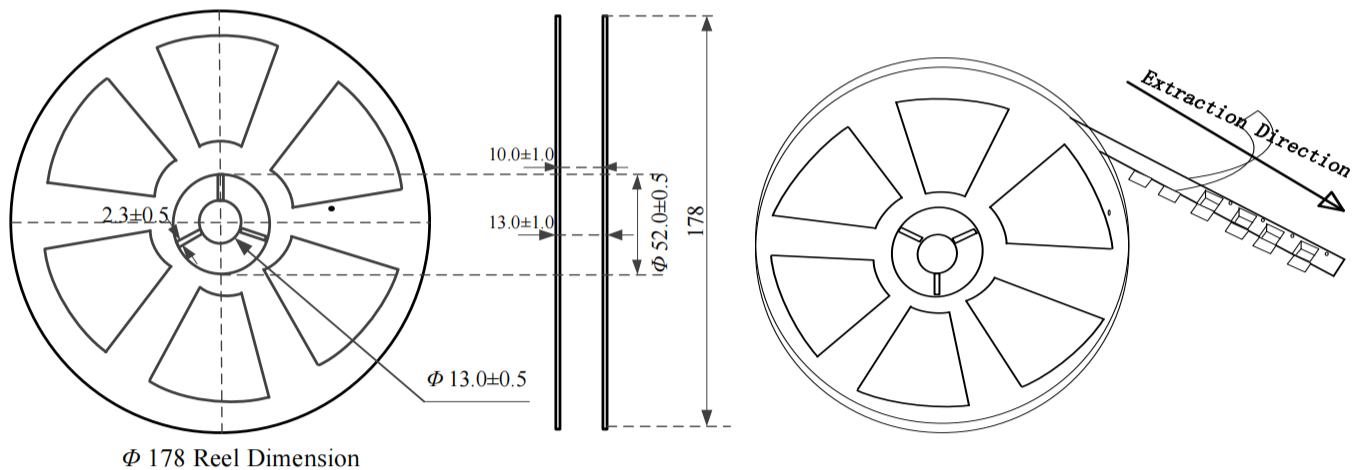

Figure 15: Drawing of reel with diameter of 178mm.