



SN74LS107 (LX) Dual JK Flip-Flop with Reset; Negative-Edge Trigger

Product Specification

Specification Revision History:

Version	Date	Description
2023-12-A0	2023-12	New
2024-03-A1	2024-03	Modify the parameters



Contents

1、 General Description.....	1
2、 Block Diagram And Pin Description	3
2.1、 Block Diagram	3
2.2、 Pin Configurations.....	3
2.3、 Pin Description.....	3
2.4、 Function Table.....	4
3、 Electrical Parameter	4
3.1、 Absolute Maximum Ratings.....	4
3.2、 Recommended Operating Conditions.....	4
3.3、 Electrical Characteristics	5
3.3.1、 DC Characteristics 1	5
3.3.2、 DC Characteristics 2	6
3.3.3、 AC Characteristics 1	7
3.3.4、 AC Characteristics 2	8
4、 Testing Circuit	9
4.1、 AC Testing Circuit	9
4.2、 Test Data	9
4.3、 AC Testing Waveforms.....	10
4.4、 Measurement Points.....	11
5、 Package Information	12
5.1、 DIP14	12
5.2、 SOP14	13
5.3、 TSSOP14.....	14
6、 Statements And Notes	15
6.1、 The name and content of Hazardous substances or Elements in the product	15
6.2、 Notes	15



1、General Description

The SN74LS107 is dual negative-edge triggered JK-type flip-flops featuring individual J, K, clock (\overline{nCP}) and reset (\overline{nR}) inputs; also complementary Q and \overline{Q} outputs.

Features:

- Supply voltage range: 2V to 6V
- Temperature range: -40°C to +125°C
- Packaging information: DIP14/SOP14/TSSOP14

Ordering Information:

Tube packing specifications:

Part number	Packaging form	Marking code	Tube quantity	Boxed tube quantity	Boxed quantity	Notes
SN74LS107N (LX)	DIP14	SN74LS107N	25 PCS/tube	40 tube/box	1000 PCS/box	Dimensions of plastic enclosure: 19.0mm×6.4mm Pin spacing: 2.54mm
SN74LS107D (LX)	SOP14	LS107	50 PCS/tube	200 tube/box	10000 PCS/box	Dimensions of plastic enclosure: 8.7mm×3.9mm Pin spacing: 1.27mm
SN74LS107P (LX)	TSSOP14	LS107	96 PCS/tube	200 tube/box	19200 PCS/box	Dimensions of plastic enclosure: 5.0mm×4.4mm Pin spacing: 0.65mm



灵星芯微 集成电路

Reel packing specifications:

Part number	Packaging form	Marking code	Reel quantity	Boxed reel quantity	Notes
SN74LS107DR(LX)	SOP14	LS107	2500 PCS/reel	5000 PCS/box	Dimensions of plastic enclosure: 8.7mm×3.9mm Pin spacing: 1.27mm
SN74LS107PW(LX)	TSSOP14	LS107	5000 PCS/reel	10000 PCS/box	Dimensions of plastic enclosure: 5.0mm×4.4mm Pin spacing: 0.65mm

Note: If the physical information is inconsistent with the ordering information, please refer to the actual product.

2、Block Diagram And Pin Description

2.1、Block Diagram

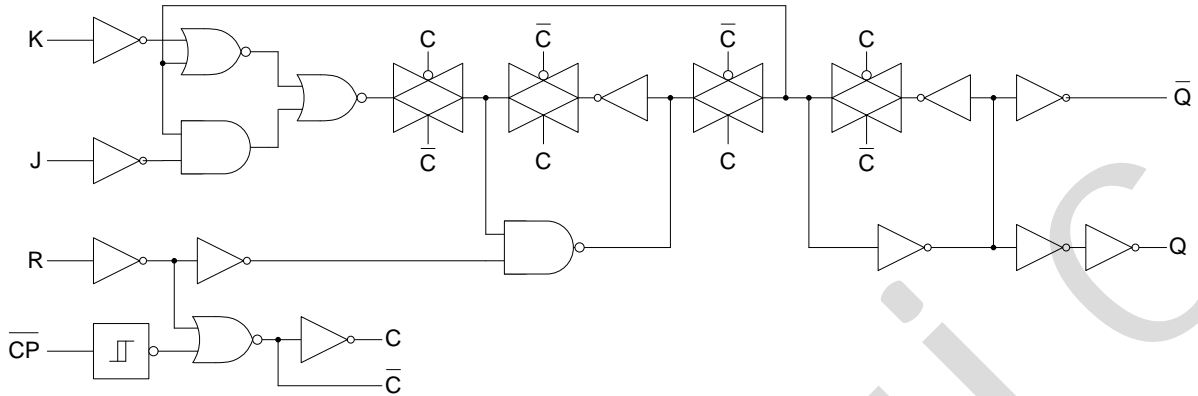

Figure 1. Logic diagram

2.2、Pin Configurations

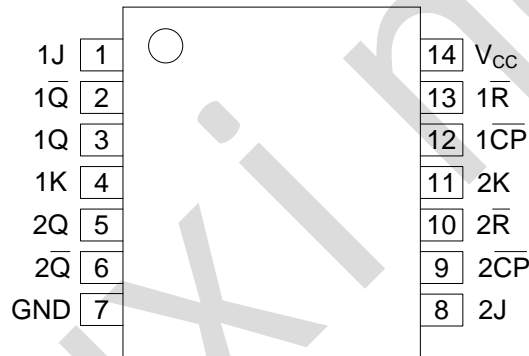

Figure 2. Pin Configurations

2.3、Pin Description

Pin No.	Pin Name	Description
1	1J	synchronous J input
2	1Q \bar{Q}	complement output
3	1Q	true output
4	1K	synchronous K input
5	2Q	true output
6	2Q \bar{Q}	complement output
7	GND	ground (0V)
8	2J	synchronous J input
9	2CP	clock input (HIGH-to-LOW edge-triggered)
10	2R \bar{R}	asynchronous reset input (active LOW)
11	2K	synchronous K input
12	1CP	clock input (HIGH-to-LOW edge-triggered)
13	1R \bar{R}	asynchronous reset input (active LOW)
14	V _{CC}	supply voltage



2.4、Function Table

Input				Output		Operating mode
\bar{nR}	\bar{nCP}	nJ	nK	nQ	\bar{nQ}	
L	X	X	X	L	H	asynchronous reset
H	↓	h	h	\bar{q}	q	toggle
H	↓	l	h	L	H	load 0 (reset)
H	↓	h	l	H	L	load 1 (set)
H	↓	l	l	q	\bar{q}	hold (no change)

Notes:

H = HIGH voltage level;

h = HIGH voltage level one set-up time prior to the HIGH-to-LOW clock transition;

L = LOW voltage level;

l = LOW voltage level one set-up time prior to the HIGH-to-LOW clock transition;

q = state of referenced output one set-up time prior to the HIGH-to-LOW clock transition;

X = don't care;

↓ = HIGH-to-LOW clock transition.

3、Electrical Parameter

3.1、Absolute Maximum Ratings

(Voltages are referenced to GND (ground=0V), unless otherwise specified.)

Parameter	Symbol	Conditions	Min.	Max.	Unit
supply voltage	V_{CC}	-	-0.5	+7	V
supply current	I_{CC}	-	-	50	mA
ground current	I_{GND}	-	-50	-	mA
input clamping current	I_{IK}	$V_I < -0.5V$ or $V_I > V_{CC}+0.5V$	-	±20	mA
output clamping current	I_{OK}	$V_O < -0.5V$ or $V_O > V_{CC}+0.5V$	-	±20	mA
output current	I_O	$-0.5V < V_O < V_{CC}+0.5V$	-	±25	mA
storage temperature	T_{stg}	-	-65	+150	°C
soldering temperature	T_L	10s	DIP		°C
			SOP/TSSOP		

3.2、Recommended Operating Conditions

Parameter	Symbol	Conditions	Min.	Typ.	Max.	Unit
supply voltage	V_{CC}	-	2.0	5.0	6.0	V
input voltage	V_I	-	0	-	V_{CC}	V
output voltage	V_O	-	0	-	V_{CC}	V
ambient temperature	T_{amb}	-	-40	-	+125	°C



3.3、Electrical Characteristics

3.3.1、DC Characteristics 1

($T_{amb} = -40^{\circ}\text{C}$ to $+85^{\circ}\text{C}$, voltages are referenced to GND (ground=0V), unless otherwise specified.)

Parameter	Symbol	V _{CC}	Conditions	Min.	Typ.	Max.	Unit
HIGH-level input voltage	V _{IH}	2.0V	-	1.5	1.2	-	V
		4.5V	-	3.15	2.4	-	V
		6.0V	-	4.2	3.2	-	V
LOW-level input voltage	V _{IL}	2.0V	-	-	0.8	0.5	V
		4.5V	-	-	2.1	1.35	V
		6.0V	-	-	2.8	1.8	V
HIGH-level output voltage	V _{OH}	2.0V	I _O =-20uA	1.9	2.0	-	V
		4.5V	I _O =-20uA	4.4	4.5	-	V
		6.0V	I _O =-20uA	5.9	6.0	-	V
		4.5V	I _O =-4.0mA	3.84	4.32	-	V
		6.0V	I _O =-5.2mA	5.34	5.81	-	V
LOW-level output voltage	V _{OL}	2.0V	I _O =20uA	-	0	0.1	V
		4.5V	I _O =20uA	-	0	0.1	V
		6.0V	I _O =20uA	-	0	0.1	V
		4.5V	I _O =4.0mA	-	0.15	0.33	V
		6.0V	I _O =5.2mA	-	0.16	0.33	V
input leakage current	I _I	6.0V	V _I =V _{CC} or GND	-	-	±1	uA
supply current	I _{CC}	6.0V	V _I =V _{CC} or GND; I _O =0A	-	-	80	uA



3.3.2、DC Characteristics 2

($T_{amb}=-40^{\circ}\text{C}$ to $+125^{\circ}\text{C}$, voltages are referenced to GND (ground=0V), unless otherwise specified.)

Parameter	Symbol	V _{CC}	Conditions	Min.	Typ.	Max.	Unit
HIGH-level input voltage	V _{IH}	2.0V	-	1.5	-	-	V
		4.5V	-	3.15	-	-	V
		6.0V	-	4.2	-	-	V
LOW-level input voltage	V _{IL}	2.0V	-	-	-	0.5	V
		4.5V	-	-	-	1.35	V
		6.0V	-	-	-	1.8	V
HIGH-level output voltage	V _{OH}	2.0V	I _O =-20uA	1.9	-	-	V
		4.5V	I _O =-20uA	4.4	-	-	V
		6.0V	I _O =-20uA	5.9	-	-	V
		4.5V	I _O =-4.0mA	3.7	-	-	V
		6.0V	I _O =-5.2mA	5.2	-	-	V
LOW-level output voltage	V _{OL}	2.0V	I _O =20uA	-	-	0.1	V
		4.5V	I _O =20uA	-	-	0.1	V
		6.0V	I _O =20uA	-	-	0.1	V
		4.5V	I _O =4.0mA	-	-	0.4	V
		6.0V	I _O =5.2mA	-	-	0.4	V
input leakage current	I _I	6.0V	V _I =V _{CC} or GND	-	-	±1	uA
supply current	I _{CC}	6.0V	V _I =V _{CC} or GND; I _O =0A	-	-	160	uA



3.3.3、AC Characteristics 1

($T_{amb} = -40^{\circ}\text{C}$ to $+85^{\circ}\text{C}$, voltages are referenced to GND (ground=0V), unless otherwise specified.)

Parameter	Symbol	V _{CC}	Conditions	Min.	Typ.	Max.	Unit				
SN74LS107											
nCP to nQ propagation delay	t _{PLH} , t _{PHL}	2.0V	C _L =50pF	see Figure 4	-	52	160	ns			
		4.5V	C _L =50pF		-	19	32	ns			
		5.0V	C _L =15pF		-	16	-	ns			
		6.0V	C _L =50pF			15	27	ns			
nCP to nQ propagation delay		2.0V	C _L =50pF		see Figure 4	-	52	200	ns		
		4.5V	C _L =50pF			-	19	40	ns		
		5.0V	C _L =15pF			-	16	-	ns		
		6.0V	C _L =50pF				15	34	ns		
nR to nQ/nQ propagation delay		t _{THL} , t _{TLH}	2.0V	C _L =50pF	see Figure 5	-	52	195	ns		
			4.5V	C _L =50pF		-	19	39	ns		
			5.0V	C _L =15pF		-	16	-	ns		
			6.0V	C _L =50pF			15	26	ns		
nQ/nQ transition time	tw		2.0V	C _L =50pF		see Figure 4	-	19	95	ns	
			4.5V	C _L =50pF			-	7	19	ns	
			6.0V	C _L =50pF			-	6	16	ns	
nCP input HIGH or LOW pulse width			trec	2.0V		C _L =50pF	see Figure 4	100	22	-	ns
		4.5V		C _L =50pF	20	8		-	ns		
		6.0V		C _L =50pF	17	6		-	ns		
nR input, HIGH pulse width		tsu		2.0V	C _L =50pF	see Figure 5		100	22	-	ns
				4.5V	C _L =50pF			20	8	-	ns
				6.0V	C _L =50pF			17	6	-	ns
nR to nCP recovery time			th	2.0V	C _L =50pF		see Figure 5	75	19	-	ns
				4.5V	C _L =50pF			15	7	-	ns
				6.0V	C _L =50pF			13	6	-	ns
nJ,nK to nCP set-up time	fmax	2.0V		C _L =50pF	see Figure 4	125		22	-	ns	
		4.5V		C _L =50pF		25		8	-	ns	
		6.0V		C _L =50pF		21		6	-	ns	
nJ,nK to nCP hold time		fmax	2.0V	C _L =50pF		see Figure 4	3	-6	-	ns	
			4.5V	C _L =50pF			3	-2	-	ns	
			6.0V	C _L =50pF			3	-2	-	ns	
maximum clock frequency	fmax	2.0V	C _L =50pF	see Figure 4	4.8	30	-	MHz			
		4.5V	C _L =50pF		24	91	-	MHz			
		6.0V	C _L =50pF		28	108	-	MHz			



3.3.4、AC Characteristics 2

($T_{amb} = -40^{\circ}\text{C}$ to $+125^{\circ}\text{C}$, voltages are referenced to GND (ground=0V), unless otherwise specified.)

Parameter	Symbol	V _{CC}	Conditions	Min.	Typ.	Max.	Unit		
nCP to nQ propagation delay	t _{PLH} , t _{PHL}	2.0V	C _L =50pF	see Figure 4	-	-	240	ns	
		4.5V	C _L =50pF		-	-	48	ns	
		6.0V	C _L =50pF				41	ns	
nCP to nQ propagation delay		t _{PLH} , t _{PHL}	2.0V	C _L =50pF	see Figure 4	-	-	240	ns
			4.5V	C _L =50pF		-	-	48	ns
			6.0V	C _L =50pF		-	-	41	ns
nR to nQ/nQ propagation delay		t _{PLH} , t _{PHL}	2.0V	C _L =50pF	see Figure 5	-	-	235	ns
			4.5V	C _L =50pF		-	-	47	ns
			6.0V	C _L =50pF				40	ns
nQ/nQ transition time	t _{THL} , t _{TLH}	2.0V	C _L =50pF	see Figure 4	-	-	110	ns	
		4.5V	C _L =50pF		-	-	22	ns	
		6.0V	C _L =50pF		-	-	19	ns	
nCP input HIGH or LOW pulse width	t _w	2.0V	C _L =50pF	see Figure 4	120	-	-	ns	
		4.5V	C _L =50pF		24	-	-	ns	
		6.0V	C _L =50pF		20	-	-	ns	
nR input, HIGH pulse width		t _w	2.0V	C _L =50pF	see Figure 5	120	-	-	ns
			4.5V	C _L =50pF		24	-	-	ns
			6.0V	C _L =50pF		20	-	-	ns
nR to nCP recovery time	t _{rec}	2.0V	C _L =50pF	see Figure 5	90	-	-	ns	
		4.5V	C _L =50pF		18	-	-	ns	
		6.0V	C _L =50pF		15	-	-	ns	
nJ,nK to nCP set-up time	t _{su}	2.0V	C _L =50pF	see Figure 4	150	-	-	ns	
		4.5V	C _L =50pF		30	-	-	ns	
		6.0V	C _L =50pF		26	-	-	ns	
nJ,nK to nCP hold time	t _h	2.0V	C _L =50pF	see Figure 4	3	-	-	ns	
		4.5V	C _L =50pF		3	-	-	ns	
		6.0V	C _L =50pF		3	-	-	ns	
maximum clock frequency	f _{max}	2.0V	C _L =50pF	see Figure 4	4.0	-	-	MHz	
		4.5V	C _L =50pF		20	-	-	MHz	
		6.0V	C _L =50pF		24	-	-	MHz	



4、Testing Circuit

4.1、AC Testing Circuit

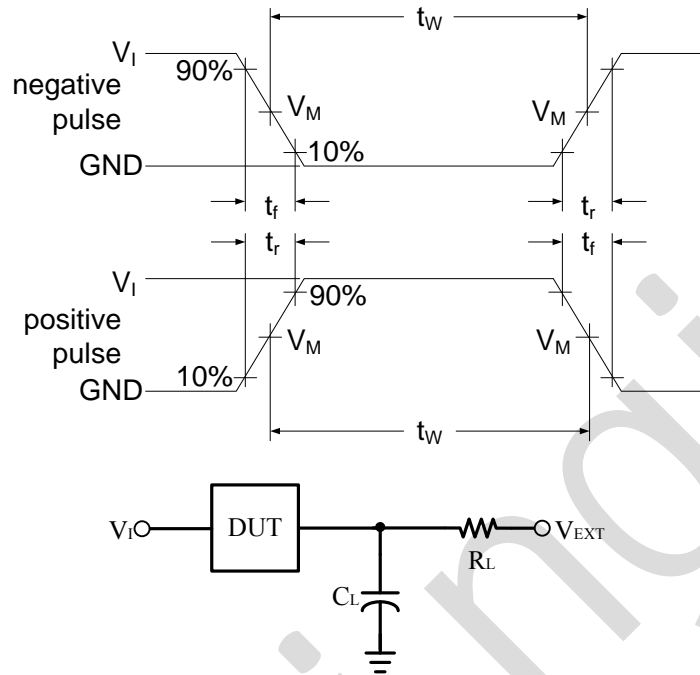

Figure 3. Test circuit for measuring switching times

C_L includes probe and jig capacitance.

4.2、Test Data

Input		Load		V_{EXT}		
V_I	$t_r = t_f$	C_L	R_L	t_{PLH}/t_{PHL}	t_{PLZ}/t_{PZL}	t_{PHZ}/t_{PZH}
V_{CC}	3.0ns	15pF, 50pF	1K Ω	Open	V_{CC}	GND



4.3、AC Testing Waveforms

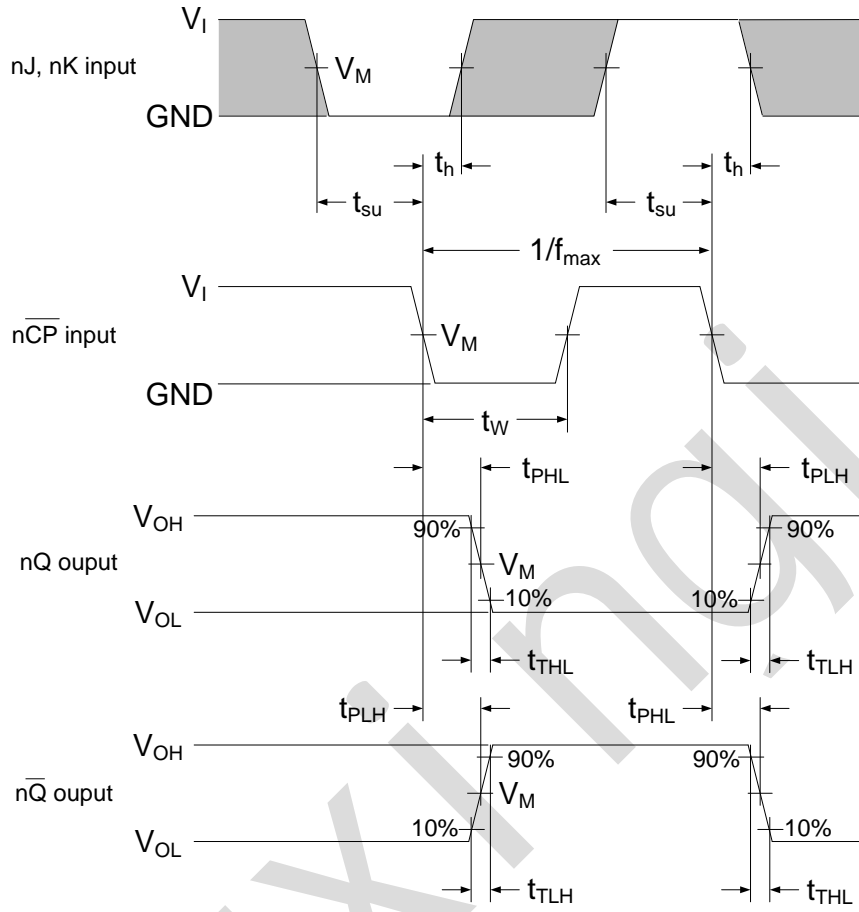

Figure 4. Clock propagation delays, pulse width, set-up and hold times, output transition times and the maximum frequency

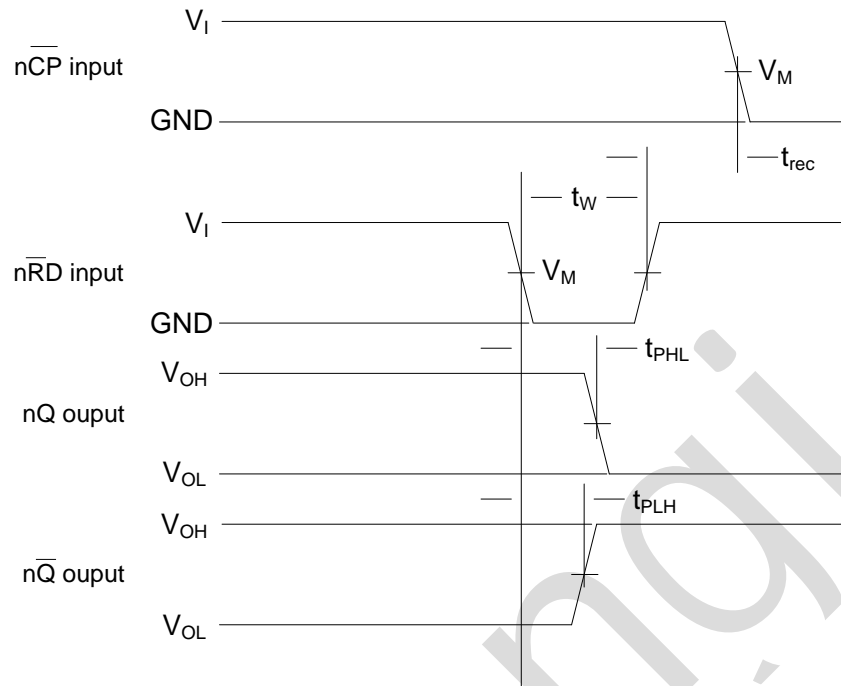

Figure 5. Reset propagation delays, pulse width and recovery time

4.4. Measurement Points

Input	Output
V_M	V_M
$0.5 \times V_{CC}$	$0.5 \times V_{CC}$



5、Package Information

5.1、DIP14

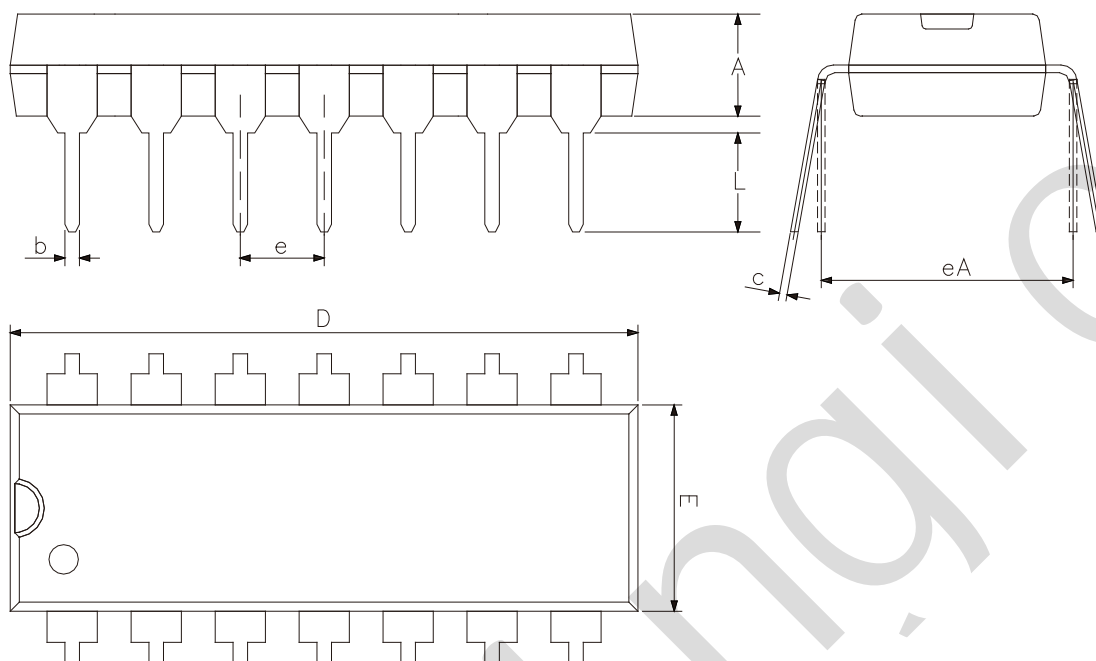

2023/12/A	Dimensions In Millimeters	
Symbol	Min	Max
A	3.05	3.60
b	0.33	0.56
c	0.20	0.36
D	18.80	19.40
E	6.20	6.60
e	2.54	
eA	7.62	10.90
L	2.92	—



5.2、SOP14

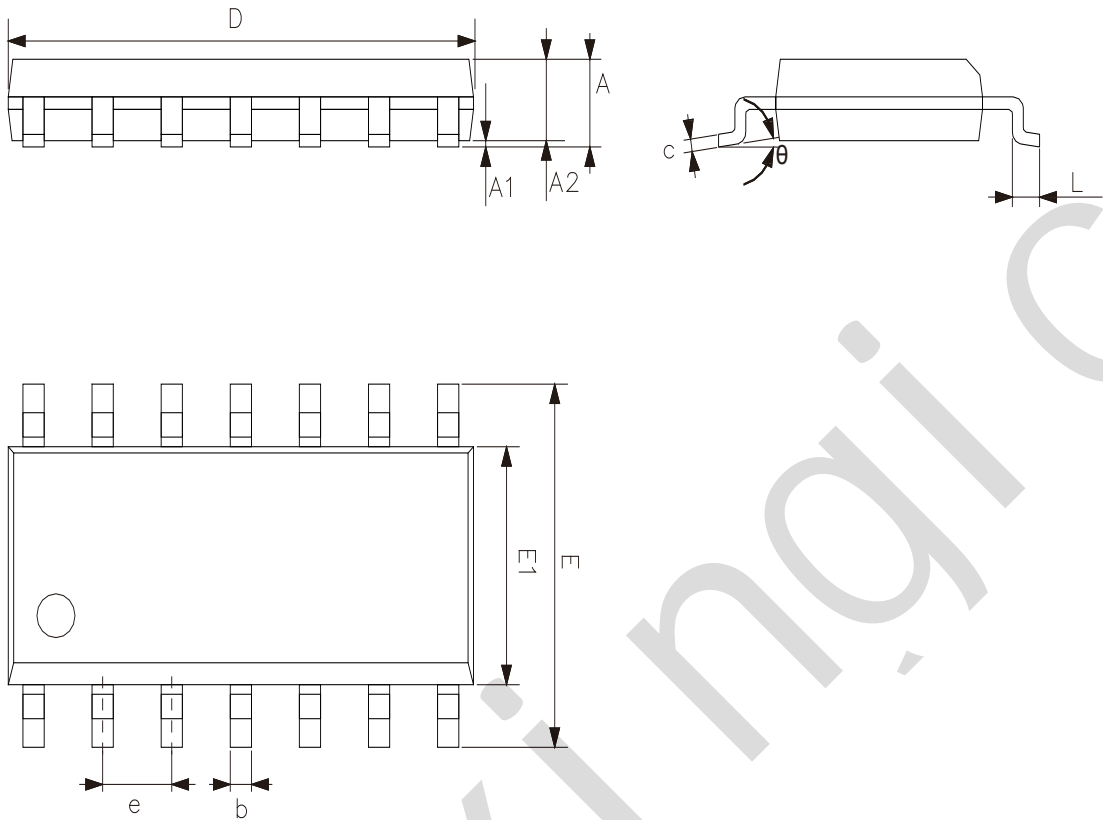

2023/12/A	Dimensions In Millimeters	
Symbol	Min.	Max.
A	1.50	1.75
A1	0.05	0.25
A2	1.30	—
b	0.33	0.50
c	0.19	0.25
D	8.43	8.76
E	5.80	6.25
E1	3.75	4.00
e	1.27	
L	0.40	0.89
θ	0°	8°



5.3、TSSOP14

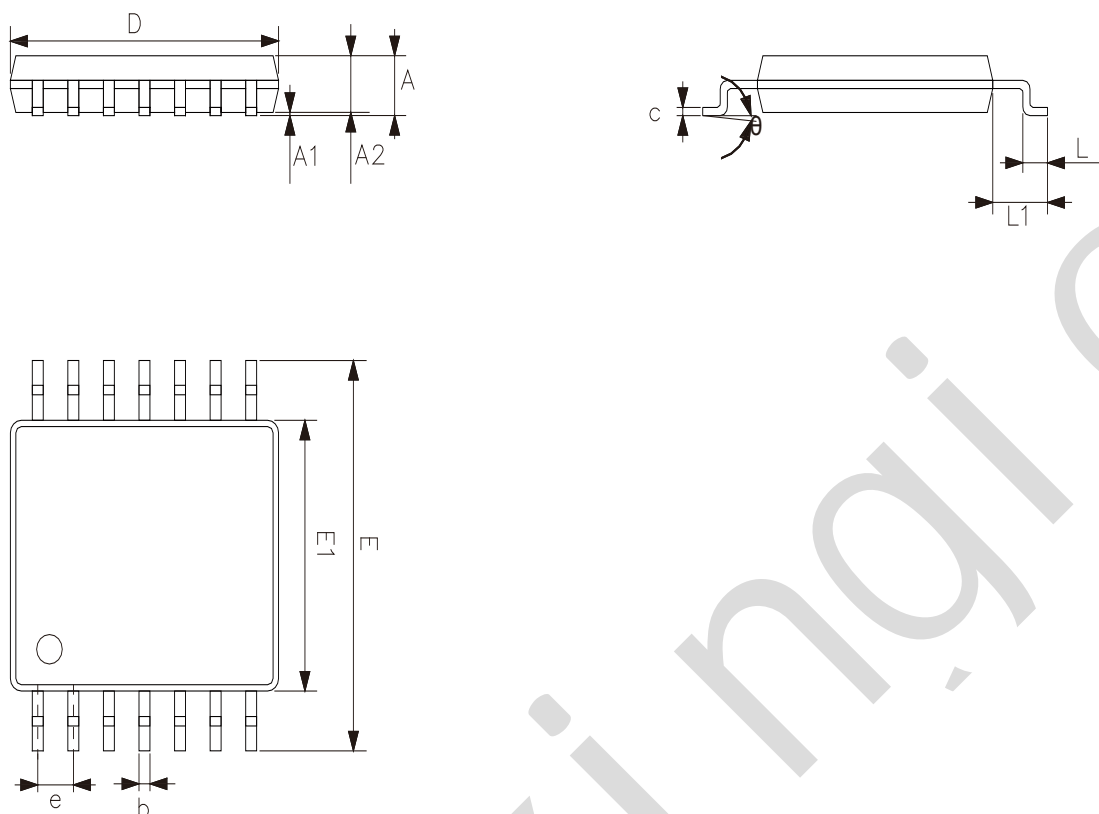

2023/12/A	Dimensions In Millimeters		
	Symbol	Min	Max
	A	—	1.20
	A1	0.05	0.15
	A2	0.80	1.05
	b	0.19	0.30
	c	0.09	0.20
	D	4.90	5.10
	E1	4.30	4.50
	E	6.20	6.60
	e	0.65	
	L	0.45	0.75
	L1	1.00	
	θ	0°	8°



6、 Statements And Notes

6.1、 The name and content of Hazardous substances or Elements in the product

Part name	Hazardous substances or Elements									
	Lead and lead compounds	Mercury and mercury compounds	Cadmium and cadmium compounds	Hexavalent chromium compounds	Polybrominated biphenyls	Polybrominated biphenyl ethers	Dibutyl phthalate	Butylbenzyl phthalate	Di-2-ethylhexyl phthalate	Diisobutyl phthalate
Lead frame	○	○	○	○	○	○	○	○	○	○
Plastic resin	○	○	○	○	○	○	○	○	○	○
Chip	○	○	○	○	○	○	○	○	○	○
The lead	○	○	○	○	○	○	○	○	○	○
Plastic sheet installed	○	○	○	○	○	○	○	○	○	○
explanation	○: Indicates that the content of hazardous substances or elements in the detection limit of the following the SJ/T11363-2006 standard. ×: Indicates that the content of hazardous substances or elements exceeding the SJ/T11363-2006 Standard limit requirements.									

6.2、 Notes

We recommend you to read this chapter carefully before using this product.

The information in this chapter is provided for reference only and Lingxing disclaims any express or implied warranties, including but not limited to applicability, special application or non-infringement of third party rights.

This product is not suitable for critical equipment such as life-saving, life-sustaining or safety equipment. It is also not suitable for applications that may result in personal injury, death, or serious property or environmental damage due to product malfunction or failure. Lingxing will not be liable for any damages incurred by the customers at their own risk for such applications.

The customer is responsible for conducting all necessary tests Lingxing's application to avoid failure in the application or the application of the customer's third party users. Lingxing does not accept any liability.

The Company reserves the right to change or improve the information published in this chapter at any time. The information in this chapter are subject to change without notice. We recommend the customer to consult our sales staff before purchasing.

Please obtain related materials form Lingxing's regular channels and we are not responsible for its content if it is provided by sources other than our company.

In case of any conflict between the Chinese and English version, the version is subject to the Chinese one.