

RoHS

MAPX

MODIFICATION

DRW

DATE

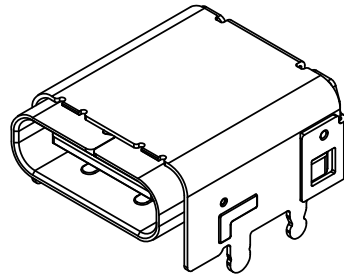
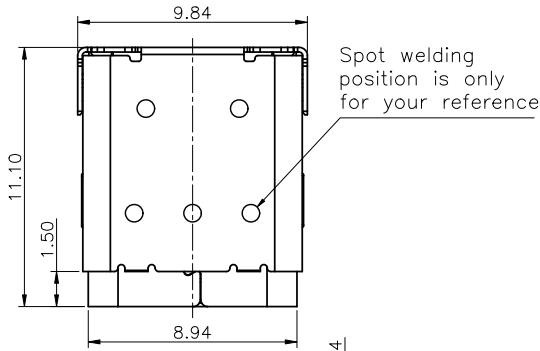

- 1.MATERIAL SPECIFICATION:SEE TABLE"A";
 - 2.MECHANICAL PERFORMANCE:
 - 2-1.INSERTION FORCE: 5~20N;
 - 2-2.REMOVAL FORCE: 8~20N,AFTER DURABILITY EXTRACTION FORCE:6~20N;
 - 2-3.DURABILITY: 10000 CYCLES;
 - 3.ELECTRICAL PERFORMANCE:
 - 3-1. CURRENT RATING:5A Max.;
 - 3-2. LLCR:
- VBUS & GND PINS AND OTHER PINS: 40mΩ/PIN MAX.;
- LLCR MAX. CHANGE OF ALL PINS: 10mΩ.;
- 3-3.INSULATION RESISTANCE: 100MΩ MIN.;
 - 3-4.DIELECTRIC WITHSTAND VOLTAGE,AC 100V FOR 1 MINUTE;
- 4.RoHS COMPLIANT;
 - 5.IR REFLOW:THE PEAK TEMPERATURE ON THE BOARD;
- 6.ENVIRONMENTAL PERFORMANCE:
 - OPERATING TEMPERATURE: -55°C~+85°C;

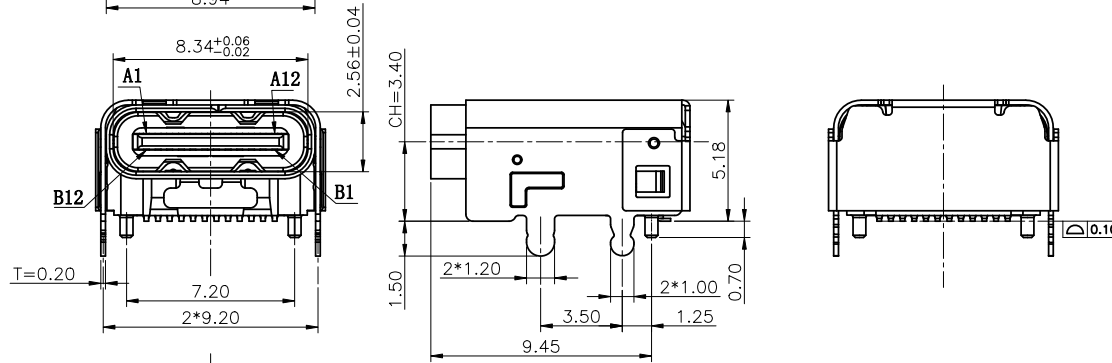

TABLE "A";

ITEM	DESCRIPTION	Q'TY	MATERIAL	FINISH
6	OUTER-SHELL	1	STAINLESS STEEL	SOLDER NICKEL: 50U" MIN
5	INNER-SHELL	1	STAINLESS STEEL	SOLDER NICKEL: 50U" MIN
4	TOP TERMINAL	1	COPPER ALLOY	MATING AREA:AU 3u" SOLDER TAIL:MATTE TIN 80 MIN, 50u" NICKEL OVERALL.
3	BOTTOM TERMINAL	1	COPPER ALLOY	MATING AREA:AU 3u" SOLDER TAIL:MATTE TIN 80 MIN, 50u" NICKEL OVERALL.
2	MID PLATE	1	STAINLESS STEEL	SOLDER NICKEL: 50U" MIN
1	MAIN HOUSING	1	HIGH TEMPERATURE	BLACK
ITEM DESCRIPTION		Q'TY	MATERIAL	FINISH

产品图
PRODUCT CHART DWG

深圳市精拓金电子有限公司
Shenzhen Jing Tuo Jin Electronics Co., Ltd.

公差一览表 TOLERANCE UNLESS OTHERWISE		单位 UNITS	MM	制图 DRAWING	L-S-S	制图料号 PRODUCT PART NO.	918-418K2029F30000
X.	±0.35	X.	±5.°	审核 CHKD	郭治富	产品名称 PRODUCT NO.	TYPE-C3. 1母11. 0CH3. 4双壳四脚间距3.5 有柱端子双排SMT/LCP脚24PIN
.X	±0.25	.X	±2.°	日期 DATE	2021-03-10	角法 VIEW	版本 VER
.XX	±0.20	.XX	±1.°	核准 APPD	黄国荣		AO
.XXX	±0.05	.XXX	±0.5°				

RoHS

MAPX

MODIFICATION

DRW

DATE

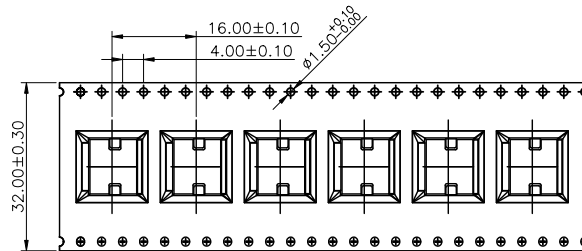
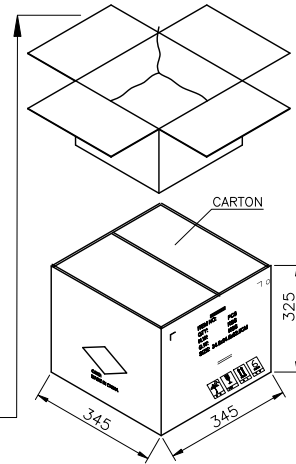
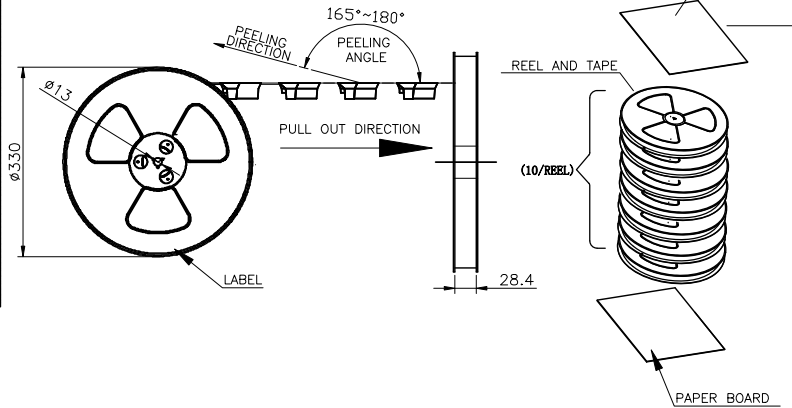
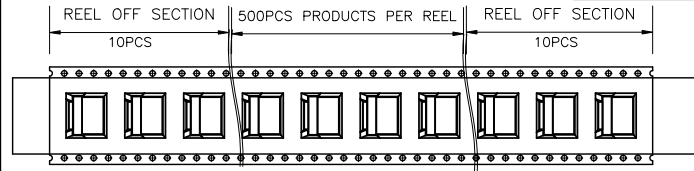
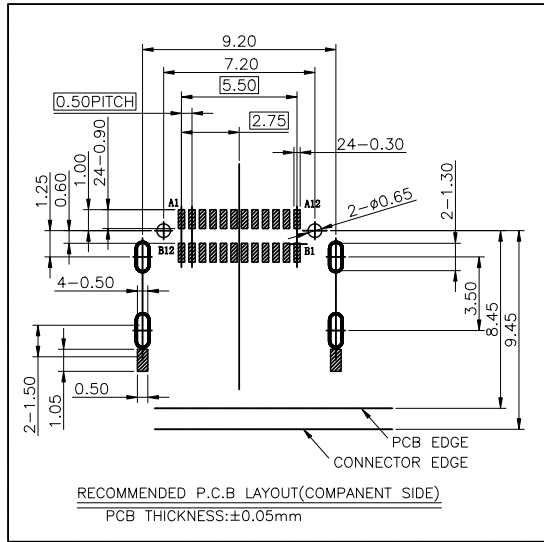

A1	GND	B12	GND
A2	SSTXP1	B11	SSRXP1
A3	SSTXN1	B10	SSRXN1
A4	VBUS	B9	VBUS
A5	CC1	B8	SBU2
A6	DP1	B7	DN2
A7	DN1	B6	DP2
A8	SBU1	B5	CC2
A9	VBUS	B4	VBUS
A10	SSRXN2	B3	SSTXN2
A11	SSRXP2	B2	SSTXP2
A12	GND	B1	GND
PIN	SIGNAL NAME	PIN	SIGNAL NAME

	REEL/TRAY	CARTON
CONNECTOR Q'TY(PCS)	500	5000

<p>产品图 PRODUCT CHART DWG</p> <p>公差一览表 TOLERANCE UNLESS OTHERWISE</p>		<p>深圳市精拓金电子有限公司 Shenzhen Jing Tuo Jin Electronics Co., Ltd.</p>								
X.	±0.35	X.	±5.°	单位	MM	制图	L-S-S	制图料号	918-418K2029F30000	
.X	±0.25	.X	±2.°	比例	1:1	审核	郭治富	产品名称	TYPE-C3.1母11.0CHS.4双壳四脚间距3.5 有柱端子双排SMT/LCP黑24PIN	
.XX	±0.20	.XX	±1.°	日期	2021-03-10	核准	黄国荣	角法		
.XXX	±0.05	.XXX	±0.5°	DATE	2021-03-10	APPD		版本	VER	A0