

Features

- Supply Voltage: 3 V to 36 V or ± 1.5 V to ± 18 V
- Low Supply Current: 100 μ A per channel
- Input Common-Mode Voltage Range Includes Ground
- Can Work as Comparators
- Rail-to-Rail Output
- Bandwidth: 0.9 MHz
- Slew Rate: 0.5 V/ μ s
- Excellent EMI Suppress Performance: 71 dB at 1 GHz
- Offset Voltage: ± 3 mV Maximum
- -40°C to 125°C Operation Temperature Range
- Qualified for Automotive Applications with AEC-Q100 Reliability Test

Applications

- Automotive
- Sensor Interface
- Motor Control

Description

The LM2904A/2902A series of amplifiers are the newest high-supply voltage amplifiers with low offset, low power, and stable frequency response. They incorporate 3PEAK’s proprietary and patented design techniques to achieve very good AC performance with 0.9-MHz bandwidth and 0.5-V/ μ s slew rate. The input common-mode voltage range extends to V_{-} , and the outputs swing rail-to-rail. The LM2904A/2902A family can be used as plug-in replacements for many commercially available op-amps to reduce power and improve input/output range and performance.

The combination of features makes the LM2904A/2902A ideal choices for the power module, industrial control, motor control, and audio applications.

Pin Configuration

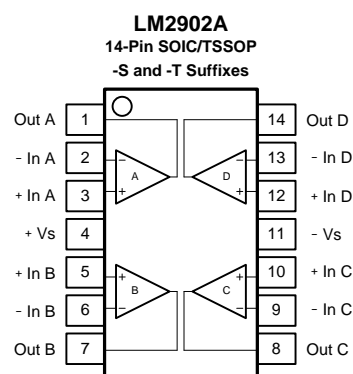
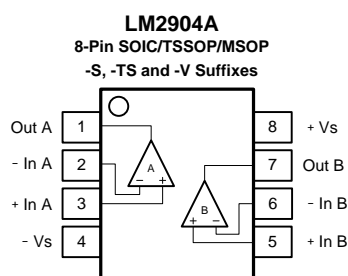

Table of Contents

Features	1
Applications	1
Description	1
Pin Configuration	1
Table of Contents	2
Revision History	3
Absolute Maximum Ratings ⁽¹⁾	4
ESD Rating	4
Thermal Information	4
Electrical Characteristics	5
Typical Performance Characteristics	7
Tape and Reel Information	9
Package Outline Dimensions	10
SOP8	10
TSSOP8	11
MSOP8	12
SOP14	13
TSSOP14	14
Order Information	15

Revision History

Date	Revision	Notes
2022-12-25	Rev.A.0	Initial version.
2023-06-01	Rev.A.1.	The following updates are all about the new datasheet formats or typo, the actual product remains unchanged. Updated address of web site. Updated tape and reel information. Updated status of LM2902A-TS2R-S and LM2902A-SO2R-S, the Q100 test is finished.

Absolute Maximum Ratings ⁽¹⁾

Parameters	Rating
Supply Voltage, (+V _S)– (-V _S)	40 V
Voltage on Input Pin and Output Pin	(–V _S) – 0.3 to (+V _S) + 0.3
Differential Input Voltage	(–V _S) – (+V _S) to (+V _S) – (–V _S)
Input Current: +IN, –IN ^{Note 2}	±10mA
Output Short-Circuit Duration ^{Note 3}	Infinite
Maximum Junction Temperature	150°C
Operating Temperature Range	–40 to 125°C
Storage Temperature Range	–65 to 150°C
Lead Temperature (Soldering, 10 sec)	260°C

Note 1: Stresses beyond those listed under Absolute Maximum Ratings may cause permanent damage to the device. Exposure to any Absolute Maximum Rating condition for extended periods may affect device reliability and lifetime.

Note 2: The inputs are protected by ESD protection diodes to each power supply. If the input extends more than 300 mV beyond the power supply, the input current should be limited to less than 10 mA.

Note 3: A heat sink may be required to keep the junction temperature below the absolute maximum. This depends on the power supply voltage and how many amplifiers are shorted. Thermal resistance varies with the amount of PC board metal connected to the package. The specified values are for short traces connected to the leads.

ESD Rating

Symbol	Parameter	Condition	Minimum Level	Unit
HBM	Human Body Model ESD	AEC-Q100-002	3	kV
CDM	Charged Device Model ESD	AEC-Q100-011	1	kV

Thermal Information

Package Type	θ_{JA}	θ_{JC}	Unit
SOP8	158	43	°C/W
TSSOP8	191	44	°C/W
MSOP8	210	45	°C/W
SOP14	120	36	°C/W
TSSOP14	180	35	°C/W

Electrical Characteristics

All test conditions: $V_S = 30\text{ V}$, $T_A = 25^\circ\text{C}$, $R_L = 10\text{ k}\Omega$, $C_L = 100\text{ pF}$, unless otherwise noted.

Symbol	Parameter	Conditions	T_A	Min	Typ	Max	Unit
Power Supply							
V_S	Supply Voltage Range			3		36	V
I_Q	Quiescent Current per Amplifier	$V_S = 30\text{ V}$			120	300	μA
			Operating Range			500	μA
PSRR	Power Supply Rejection Ratio	$V_S = 5\text{ V to } 36\text{ V}$		80	120		dB
			Operating Range	70			dB
Input Characteristics							
V_{OS}	Input Offset Voltage	$V_S = 30\text{ V}, V_{CM} = 0\text{ V to } 28\text{ V}$		-4	1	4	mV
			Operating Range	-7		7	mV
		$V_S = 5\text{ V}, V_{CM} = 0\text{ V to } 3\text{ V}$		-4	1	4	mV
			Operating Range	-7		7	mV
$V_{OS\text{ TC}}$	Input Offset Voltage Drift		Operating Range		7		$\mu\text{V}/^\circ\text{C}$
I_B	Input Bias Current ⁽¹⁾				60	1000	pA
			Operating Range		600	2000	pA
I_{OS}	Input Offset Current ⁽¹⁾				60	1000	pA
			Operating Range		600	2000	pA
R_{IN}	Input Impedence				10^{10}		Ω
C_{IN}	Input Capacitance	Differential Mode			5		pF
		Common Mode			5		pF
A_V	Open-loop Voltage Gain			90	110		dB
			Operating Range	85			dB
V_{CMR}	Common-Mode Input Voltage Range		Operating Range	(V-)		(V+) - 2	V
CMRR	Common Mode Rejection Ratio	$V_{CM} = 0\text{ V to } 28\text{ V}$		65	120		dB
			Operating Range	60	90		dB
Output Characteristics							
	Output Voltage Swing from Positive and Negative Rail	$R_{LOAD} = 10\text{ k}\Omega\text{ to } V_S/2$			200	500	mV
			Operating Range			1000	mV
		$R_{LOAD} = 2\text{ k}\Omega\text{ to } V_S/2$			1.1	1.5	V
			Operating Range			3	V
	Output Voltage Swing from Negative Rail	$V_S = 5\text{ V}, R_{LOAD} = 10\text{ k}\Omega\text{ to } 0\text{ V}$			5	20	mV
I_{SC}	Output Short-Circuit Current			10	25		mA
			Operating Range	5			mA

(1) Provided by bench test and design simulation

AC Specifications							
GBW	Gain-Bandwidth Product				0.9		MHz
SR	Slew Rate	G = 1, 2 V step			0.5		V/ μ s
t_s	Settling Time, 0.1%	G = 1, 2 V step			4		μ s
	Settling Time, 0.01%				5		μ s
PM	Phase Margin	$V_s = 30$ V, $R_L = 1$ K, $C_L = 100$ pF			60		$^\circ$
GM	Gain Margin	$V_s = 30$ V, $R_L = 1$ K, $C_L = 100$ pF			15		dB
	Channel Separation	f = 1 kHz to 20 kHz			120		dB
Noise Performance							
E_N	Input Voltage Noise	f = 0.1 Hz to 10 Hz			3		μ V _{RMS}
e_N	Input Voltage Noise Density	f = 1 kHz			70		nV/ \sqrt Hz
i_N	Input Current Noise	f = 1 kHz			3		fA/ \sqrt Hz

Typical Performance Characteristics

All test conditions: $V_s = \pm 15\text{ V}$, $V_{CM} = 0\text{ V}$, $R_L = 10\text{ k}\Omega$, unless otherwise specified.

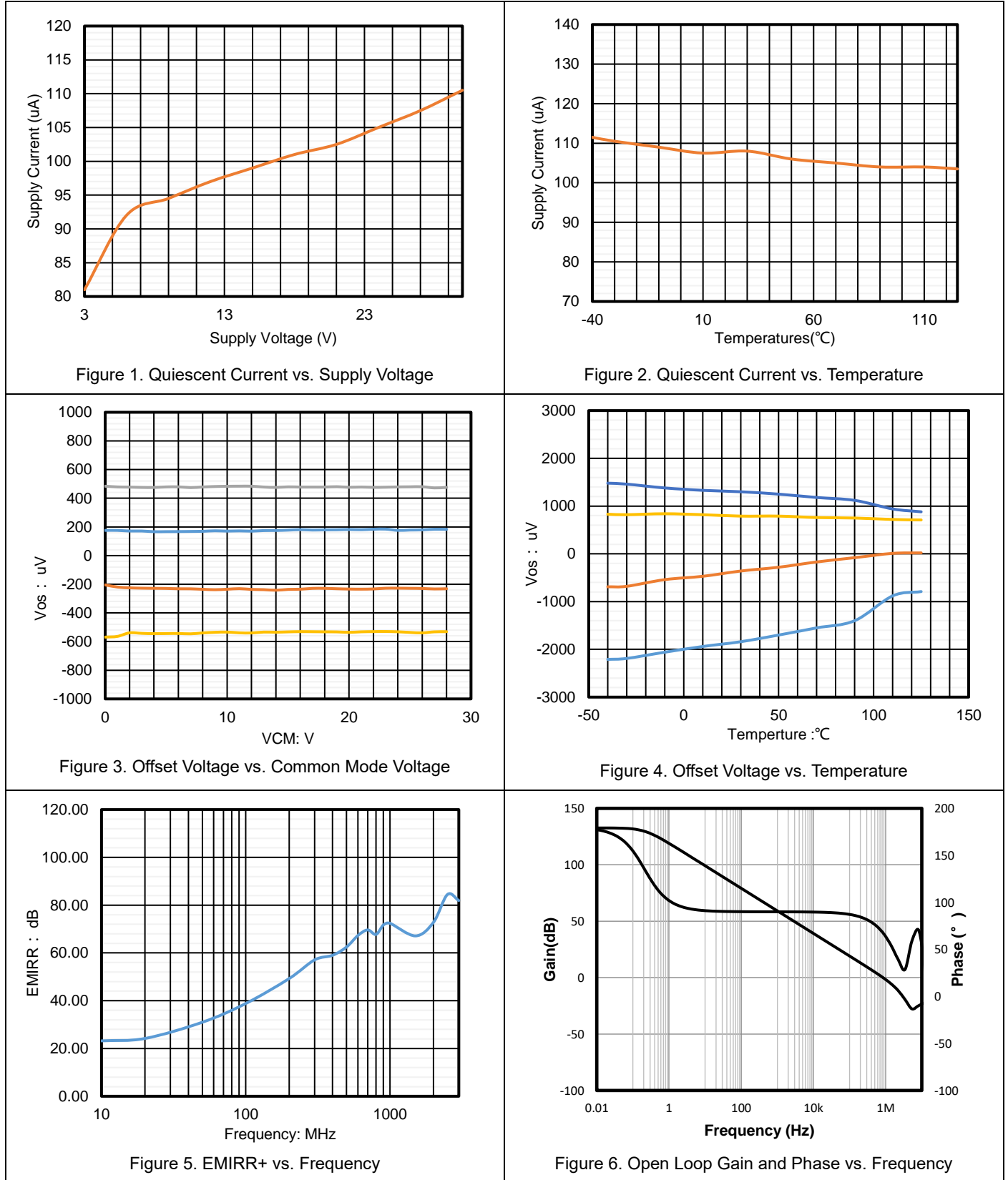

All test conditions: $V_S = \pm 15\text{ V}$, $V_{CM} = 0\text{ V}$, $R_L = 10\text{ k}\Omega$, unless otherwise specified.

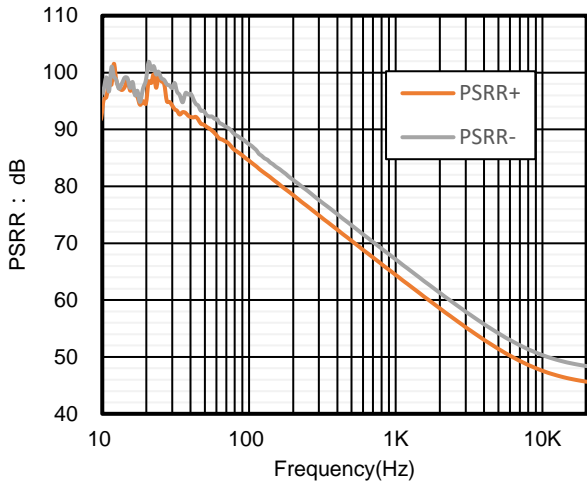

Figure 7. PSRR vs. Frequency

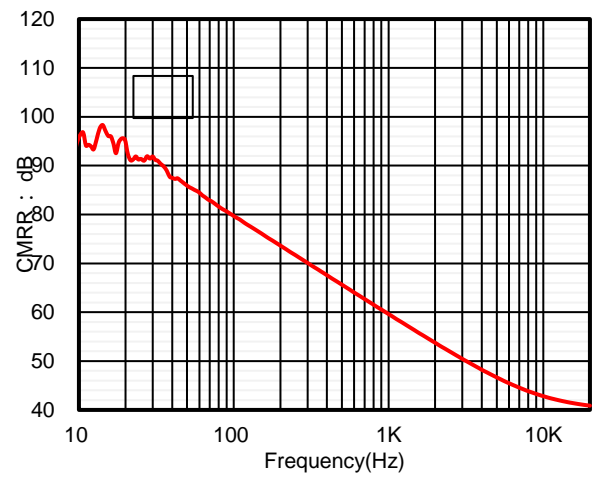

Figure 8. CMRR vs. Frequency

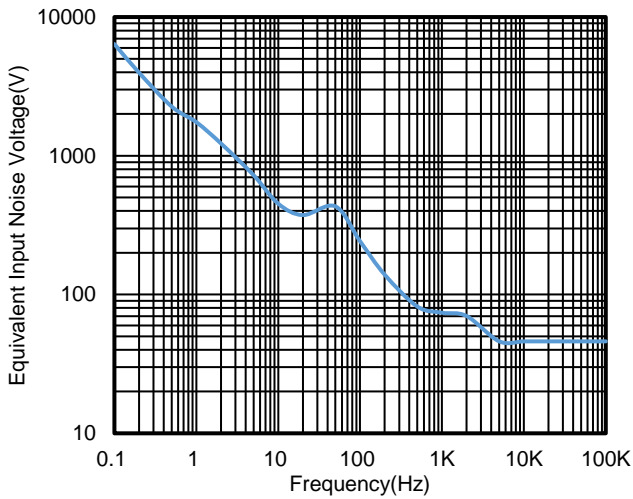

Figure 9. Voltage Noise Spectral Density vs. Frequency

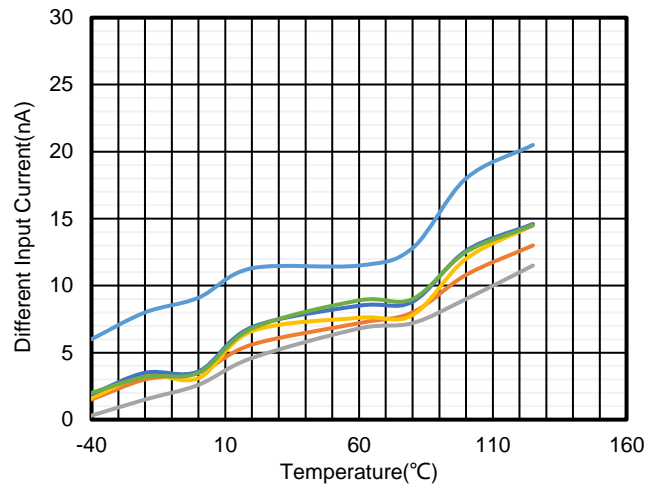
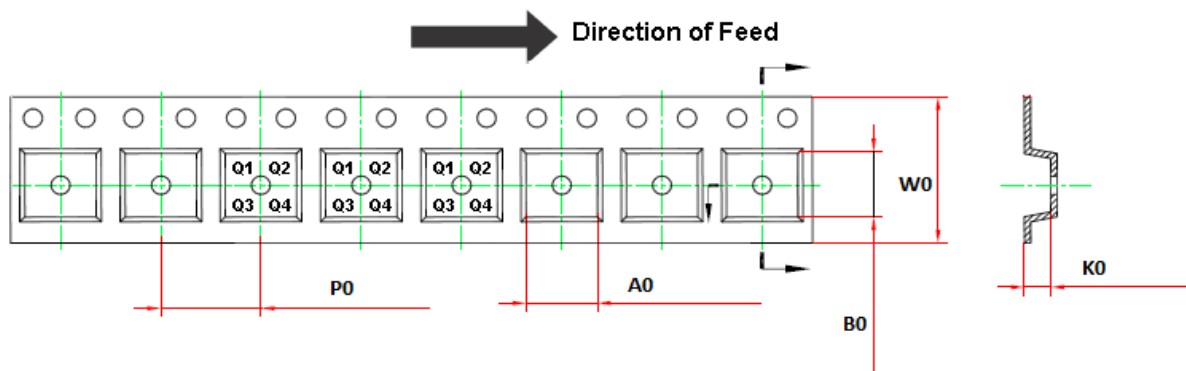
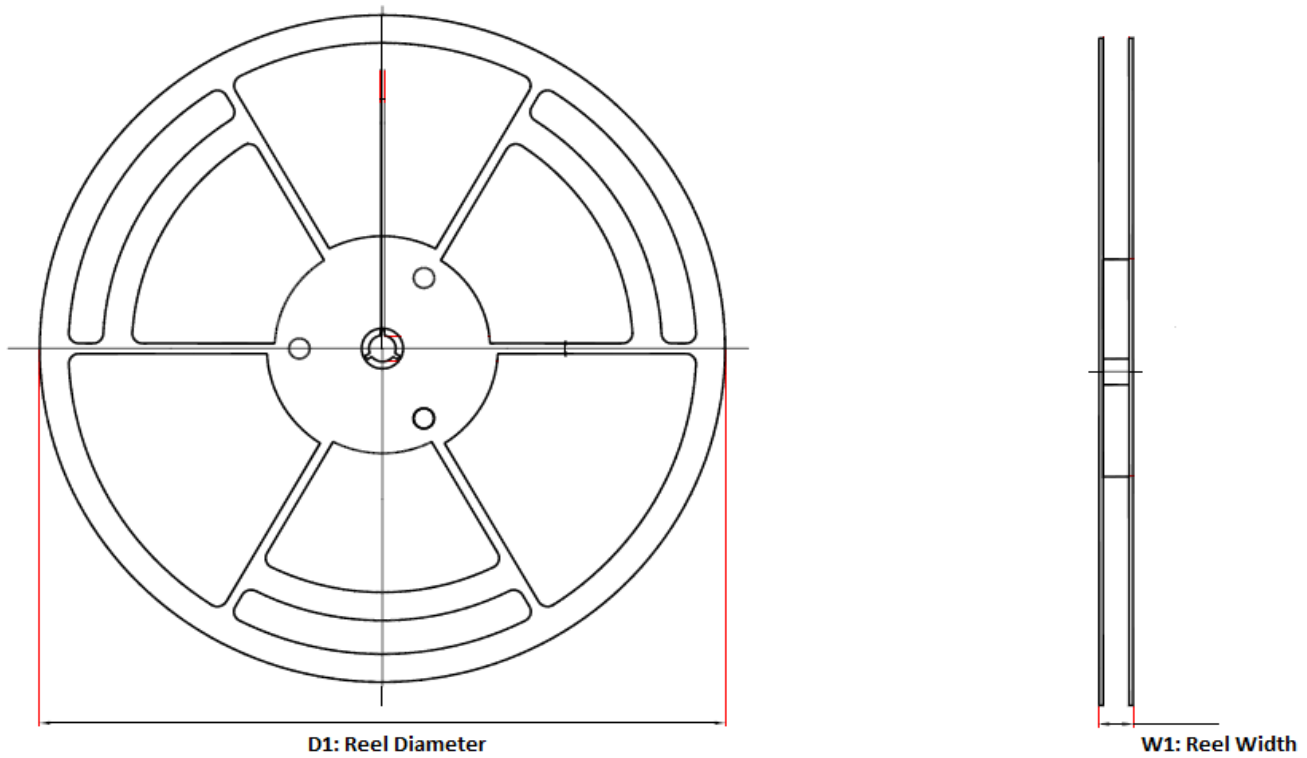

Figure 10. Different Input Current vs. Temperature

Tape and Reel Information



Order Number	Package	D1	W1	A0	B0	K0	P0	W0	Pin1 Quadrant
LM2904A-SO1R-S	SOP8	330.0	17.6	6.5	5.4	2.0	8.0	12.0	Q1
LM2904A-VS1R-S	MSOP8	330.0	17.6	5.2	3.3	1.5	8.0	12.0	Q1
LM2904A-TS1R-S	TSSOP8	330.0	17.6	6.8	3.3	1.7	8.0	12.0	Q1
LM2902A-SO2R-S	SOP14	330.0	21.6	6.5	9.2	1.8	8.0	16.0	Q1
LM2902A-TS2R-S	TSSOP14	330.0	17.6	6.8	5.5	1.7	8.0	12.0	Q1

Package Outline Dimensions

SOP8

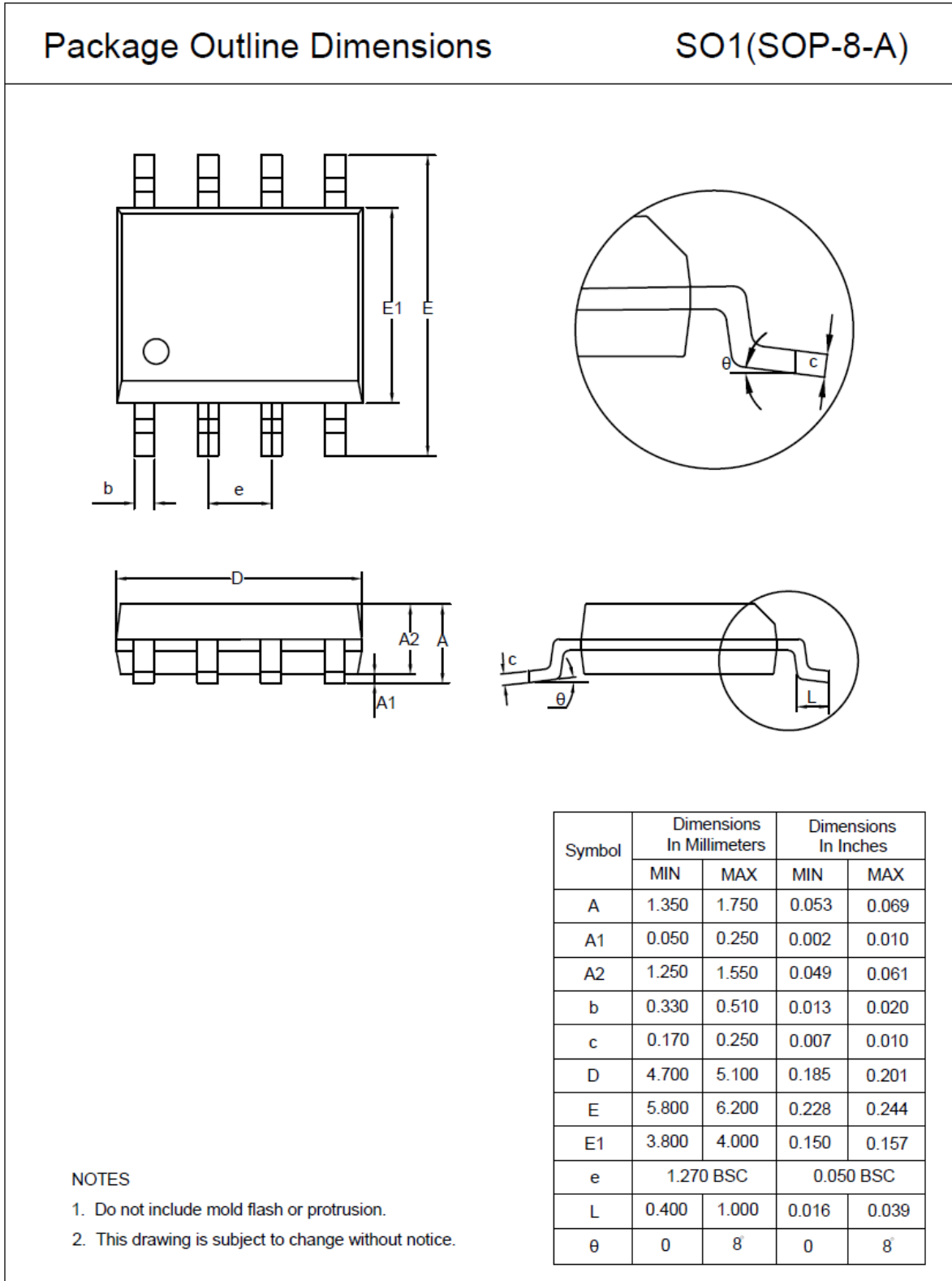

TSSOP8

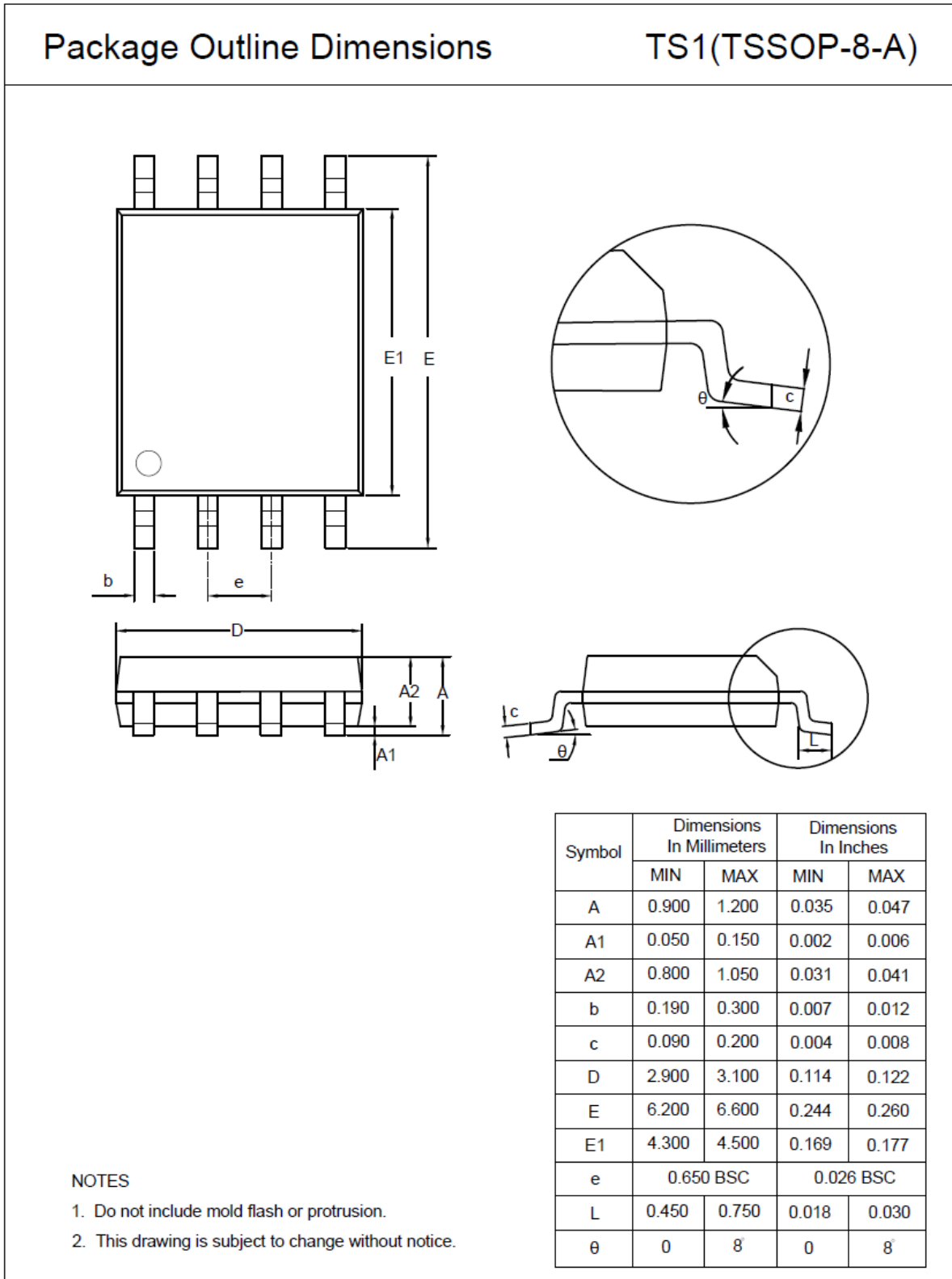

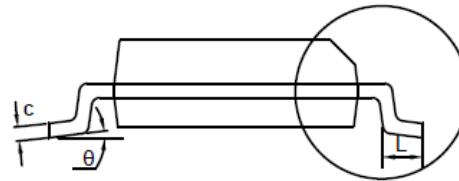
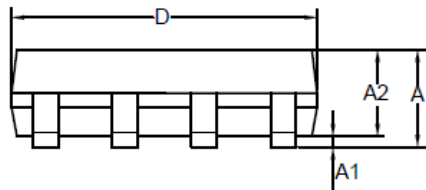
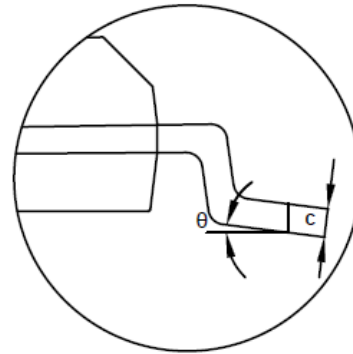
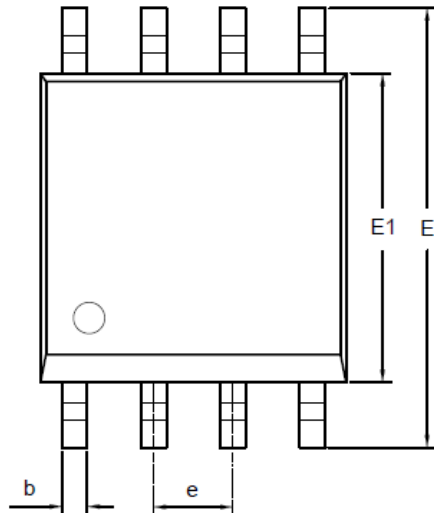
MSOP8
Package Outline Dimensions
VS1(MSOP-8-A)

Symbol	Dimensions In Millimeters		Dimensions In Inches	
	MIN	MAX	MIN	MAX
A	0.800	1.100	0.031	0.043
A1	0.050	0.150	0.002	0.006
A2	0.750	0.950	0.030	0.037
b	0.250	0.380	0.010	0.015
c	0.090	0.230	0.004	0.009
D	2.900	3.100	0.114	0.122
E	4.700	5.100	0.185	0.201
E1	2.900	3.100	0.114	0.122
e	0.650 BSC		0.026 BSC	
L	0.400	0.800	0.016	0.031
θ	0	8°	0	8°

NOTES

1. Do not include mold flash or protrusion.
2. This drawing is subject to change without notice.

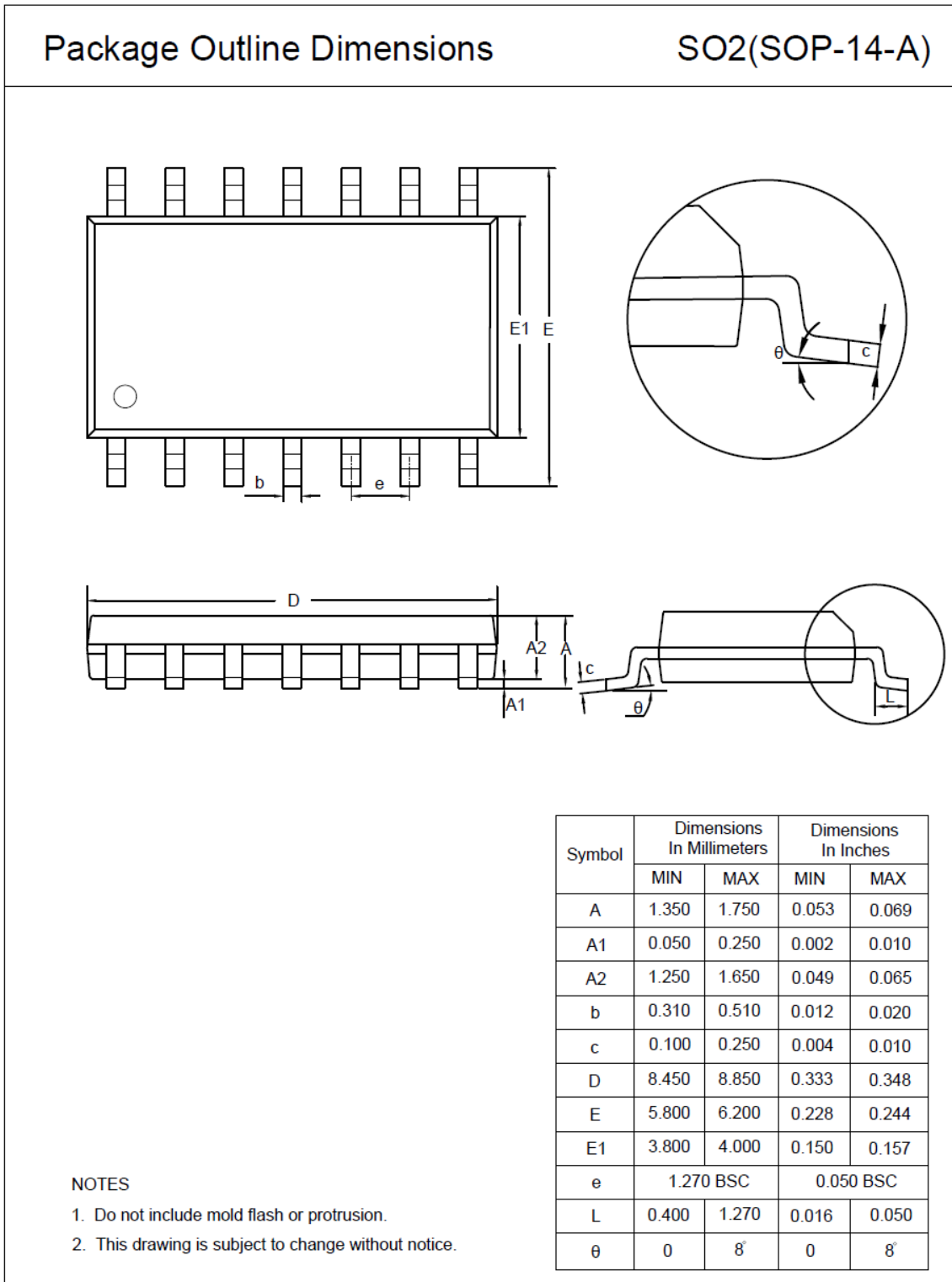
SOP14

TSSOP14

Package Outline Dimensions

TS2(TSSOP-14-A)

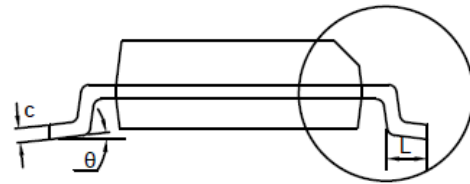
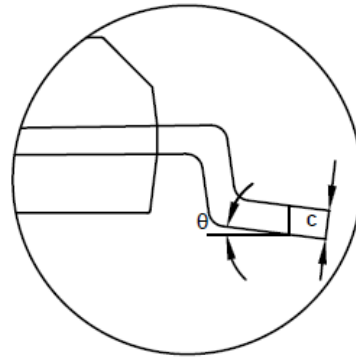
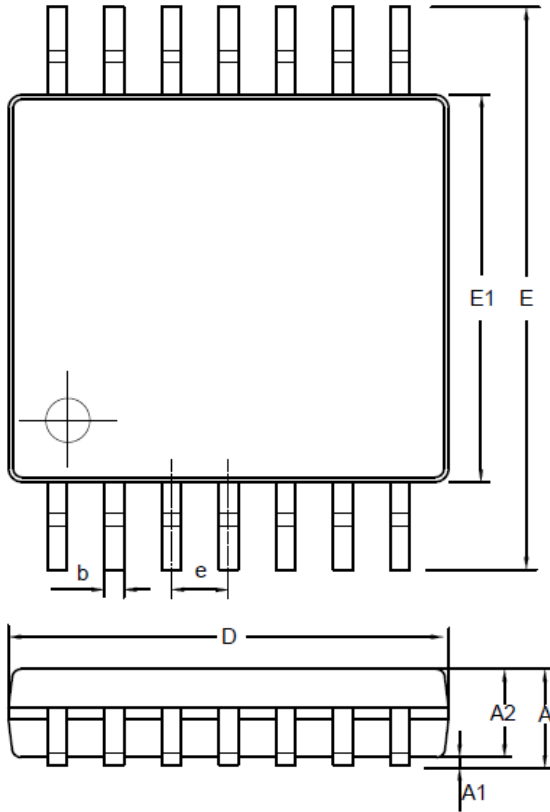

Symbol	Dimensions In Millimeters		Dimensions In Inches	
	MIN	MAX	MIN	MAX
A	0.900	1.200	0.035	0.047
A1	0.050	0.150	0.002	0.006
A2	0.800	1.050	0.031	0.041
b	0.190	0.300	0.007	0.012
c	0.090	0.200	0.004	0.008
D	4.900	5.100	0.193	0.201
E	6.200	6.600	0.244	0.260
E1	4.300	4.500	0.169	0.177
e	0.650 BSC		0.026 BSC	
L	0.450	0.750	0.018	0.030
theta	0	8°	0	8°

NOTES

1. Do not include mold flash or protrusion.
2. This drawing is subject to change without notice.

Order Information

Order Number	Operating Temperature Range	Package	Marking Information	MSL	Transport Media, Quantity
LM2904A-SO1R-S	-40 to 125°C	SOP8	2904S	3	Tape and Reel, 4000
LM2904A-TS1R-S	-40 to 125°C	TSSOP8	2904S	3	Tape and Reel, 3000
LM2904A-VS1R-S	-40 to 125°C	MSOP8	2904S	3	Tape and Reel, 3000
LM2902A-SO2R-S	-40 to 125°C	SOP14	2902S	3	Tape and Reel, 2500
LM2902A-TS2R-S	-40 to 125°C	TSSOP14	2902S	3	Tape and Reel, 3000

 **3PEAK and the 3PEAK logo are registered trademarks of 3PEAK INCORPORATED. All other trademarks are the property of their respective owners.**

IMPORTANT NOTICE AND DISCLAIMER

Copyright© 3PEAK 2012-2023. All rights reserved.

Trademarks. Any of the 思瑞浦 or 3PEAK trade names, trademarks, graphic marks, and domain names contained in this document /material are the property of 3PEAK. You may NOT reproduce, modify, publish, transmit or distribute any Trademark without the prior written consent of 3PEAK.

Performance Information. Performance tests or performance range contained in this document/material are either results of design simulation or actual tests conducted under designated testing environment. Any variation in testing environment or simulation environment, including but not limited to testing method, testing process or testing temperature, may affect actual performance of the product.

Disclaimer. 3PEAK provides technical and reliability data (including data sheets), design resources (including reference designs), application or other design recommendations, networking tools, security information and other resources "As Is". 3PEAK makes no warranty as to the absence of defects, and makes no warranties of any kind, express or implied, including without limitation, implied warranties as to merchantability, fitness for a particular purpose or non-infringement of any third-party's intellectual property rights. Unless otherwise specified in writing, products supplied by 3PEAK are not designed to be used in any life-threatening scenarios, including critical medical applications, automotive safety-critical systems, aviation, aerospace, or any situations where failure could result in bodily harm, loss of life, or significant property damage. 3PEAK disclaims all liability for any such unauthorized use.