

# CD4518 Dual BCD Up-Counter

# CD4520 Dual Binary Up-Counter

## 1. General Description

### 1.1 Description

CD4518 Dual BCD Up Counter and CD4520 Dual Binary Up Counter each consist of two identical, internally synchronous 4-stage counters. The counter stages are D-type flip-flops having interchangeable CLOCK and ENABLE lines for incrementing on either the positive-going or negative-going transition. For single unit operation the ENABLE input is maintained high and the counter advances on each positive-going transition of the CLOCK. The counters are cleared by high levels on their RESET lines. The counter can be cascaded in the ripple mode by connecting Q4 to the enable input of the subsequent counter while the CLOCK input of the latter is held low.

### 1.2 Features

- Positive or negative edge triggering
- Synchronous internal carry propagation
- 100% tested for quiescent current at 18V
- Maximum input current of 1 $\mu$ A at 18V (temperature : +25 $^{\circ}$ C)
- Standardized symmetrical output characteristics

### 1.3 Device Information

PART NUMBER	PACKAGE
CD4518 CD4520	DIP
	SOP
	TSSOP

## 2. Pin Description and Functional Diagram

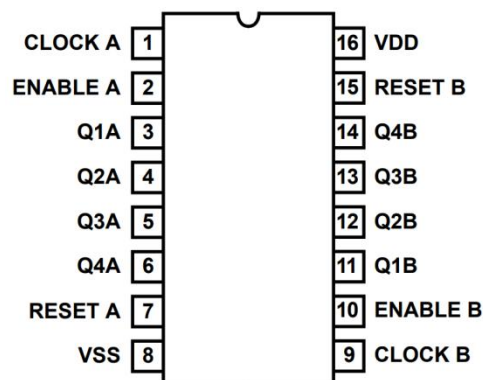

Figure 2.1 Top View

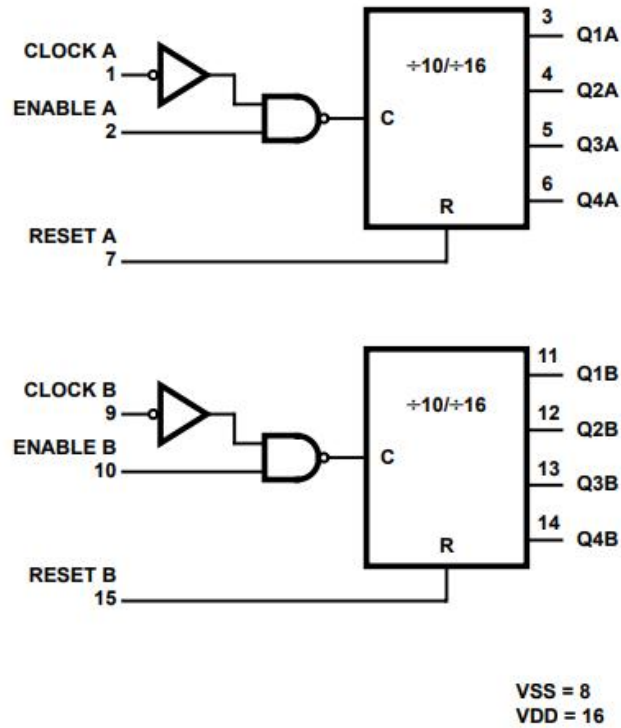

Figure 2.2 Functional Diagram

### 3. System Diagram

#### 3.1 Logic Diagram

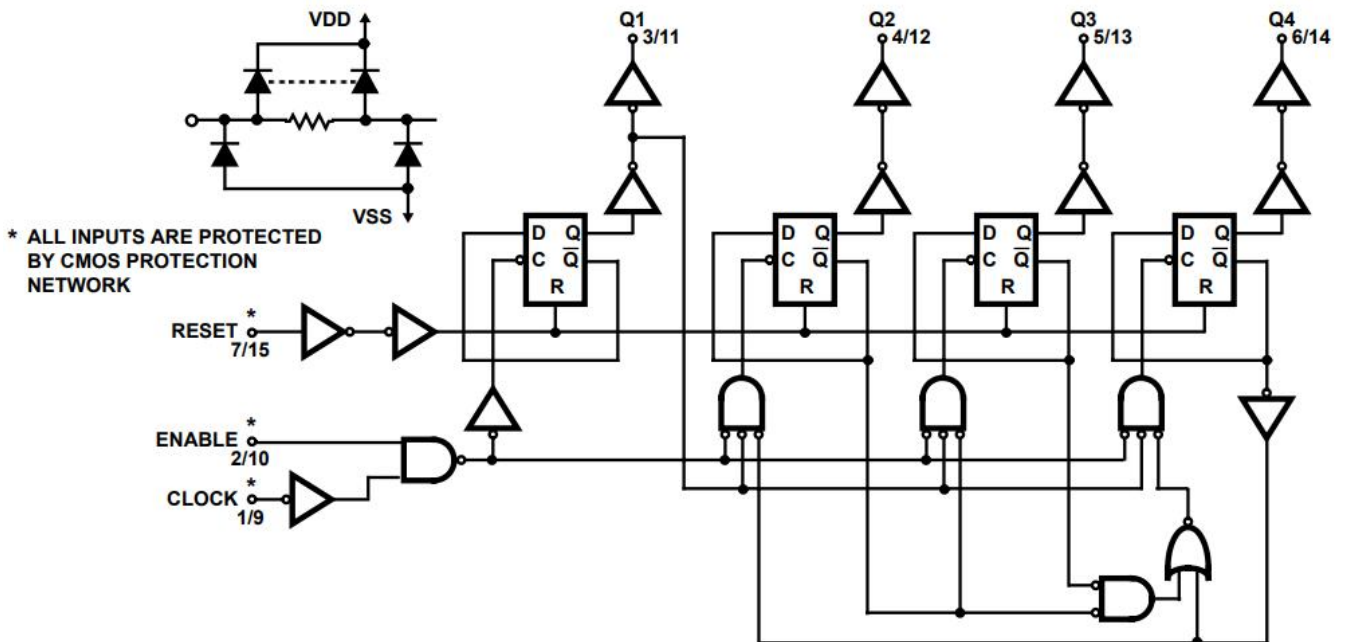

Figure 3.1: CD4518 Logic Diagram for one or two identical counters

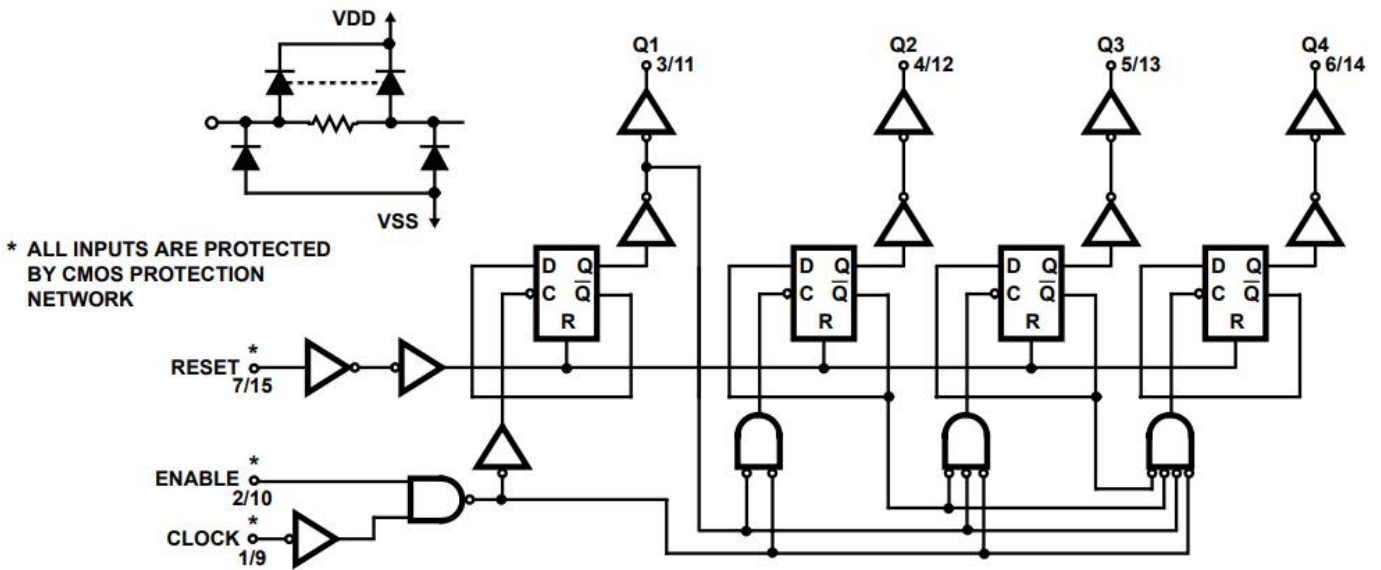

Figure 3.2: CD4520 Logic Diagram for one or two identical counters

### 3.2 Truth Table

Clock	Enable	Reset	Action
↑	1	0	Increment Counter
0	↓	0	Increment Counter
↓	X	0	No Change
X	↑	0	No Change
↑	0	0	No Change
1	↓	0	No Change
X	X	1	Q1 thru Q4 = 0

X = Don't Care, 1 ≡ High State, 0 ≡ Low State, ↑=positive-going transition, ↓=negative-going transition.

## 4. Specifications

### 4.1 Absolute Maximum Ratings

Symbol	Parameter	MIN	MAX	Unit
VDD	DC Supply Voltage Range (Voltage Referenced to VSS Terminals)	-0.5	20	V
V <sub>i</sub>	Input Voltage Range, All Inputs	0.5	VDD+0.5	V
P <sub>D</sub>	Power Dissipation		500	mW
T <sub>J</sub>	Junction Temperature		125	°C
T <sub>OP</sub>	Operating Temperature	-45	85	°C

Absolute maximum ratings are those values beyond which the device could be permanently damaged, These are stress ratings only, which do not imply functional operation of the device at these or any other conditions beyond those indicated under Recommended Operating Conditions.



## 4.2 Electrical Characteristics

( $T_a=25^{\circ}\text{C}$ , voltages are referenced to VSS (ground=0V), unless otherwise specified)

Symbol	Parameter	Test Condition			MIN	TYP	MAX	Unit
		VO	VIN	VDD				
I <sub>DD</sub>	Supply Current		0,5	5	--		1	uA
			0,10	10	--		1	uA
			0,18	18	--		1	uA
I <sub>OL</sub>	Low Level Output Current	0.4	0,5	5	1.5	2.5	--	mA
			0,10	10	3	6	--	mA
			0,15	15	13	24	--	mA
I <sub>OH</sub>	High Level Output Current	4.6	0,5	5	-0.5	-1.3	--	mA
			0,5	5	-3	-5.5	--	mA
			0,10	10	-1.5	-3	--	mA
			0,15	15	-5	-10	--	mA
V <sub>OL</sub>	Low Level Output Voltage		0,5	5	--	0.0	0.05	V
			0,10	10	--	0.0	0.05	V
			0,15	15	--	0.0	0.05	V
V <sub>OH</sub>	High Level Output Voltage		0,5	5	4.95	5	--	V
			0,10	10	9.95	10	--	V
			0,15	15	14.95	15	--	V
V <sub>IL</sub>	Low Level Input Voltage	0.5,4.5		5	--		1.5	V
			1,9	10	--		3	V
			1.5,13.5	15	--		4	V
V <sub>IH</sub>	High Level Input Voltage	0.5,4.5		5	3.5		--	V
			1,9	10	7		--	V
			1.5,13.5	15	11		--	V
I <sub>IN</sub>	Input Leakage Current		0,18	18			±1	uA

## 5. Timing Diagrams

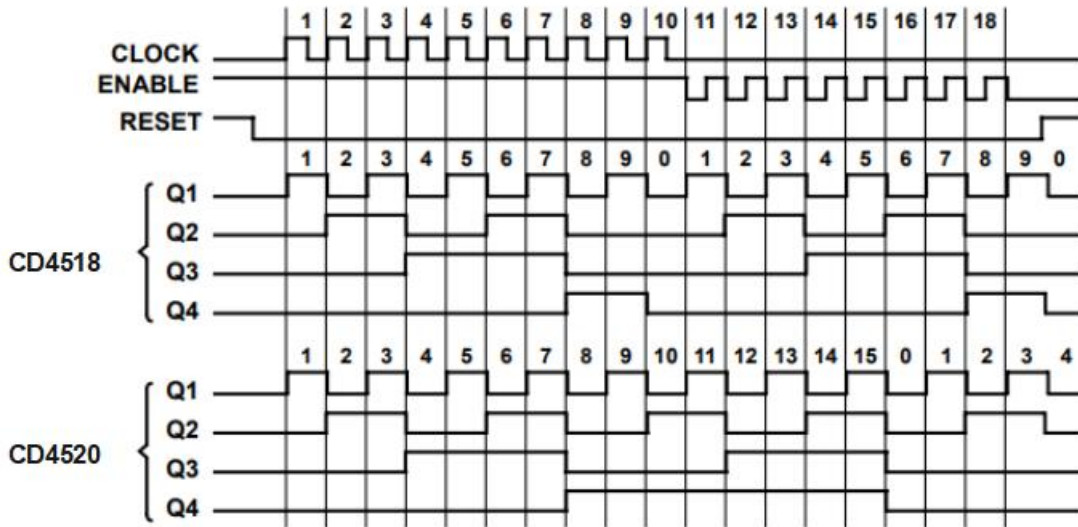

Figure 6.1: Timing diagrams for CD4518 and CD4520

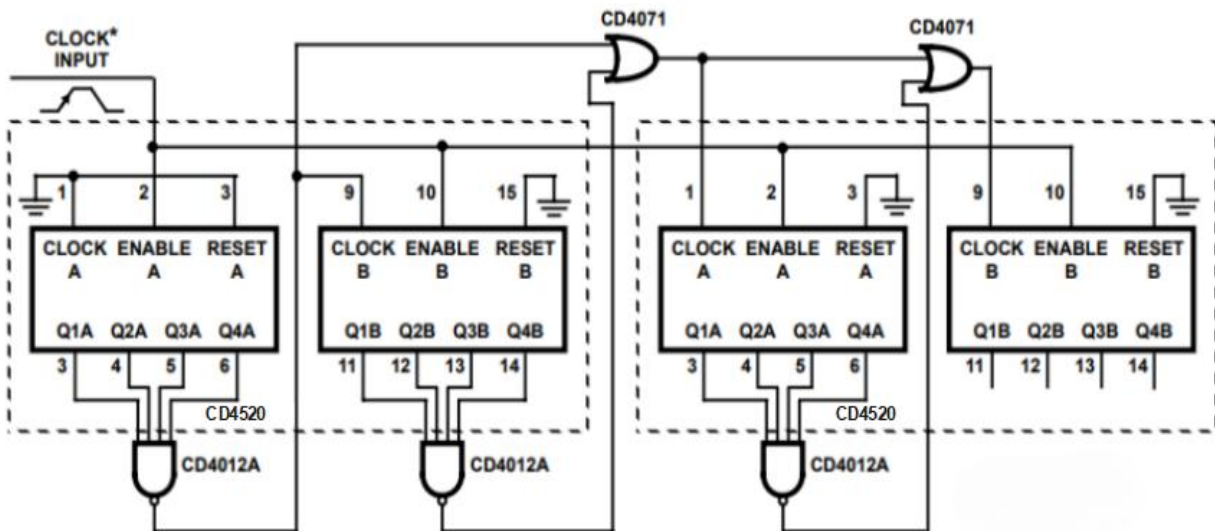

Figure 6.2: Ripple cascading of four counters with positive edge triggering

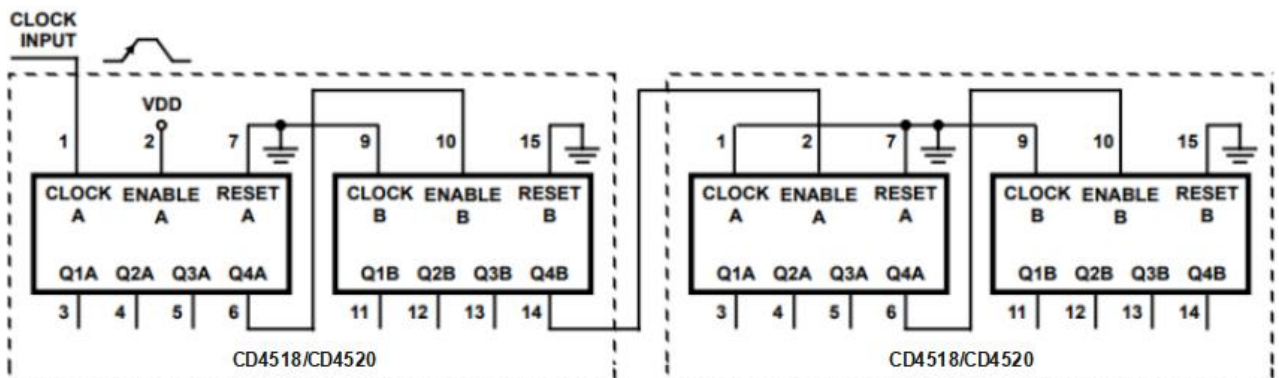

Figure 6.2: Synchronous cascading of four counters with negative edge triggering

\*For synchronous cascading, the clock transition time should be made less than or equal to the sum of the fixed propagation delay at 15pF and the transition time of the output driver stage for the estimated capacitive load.



## 6. Ordering Information

Orderable Device	Package Type	Pins	Packing	Package Qty
CD4518ND16ATBE	DIP	16	Tube	25
CD4518NS16ARDQ	SOP	16	Tape & Reel	4000
CD4518TS16ARDQ	TSSOP	16	Tape & Reel	4000
CD4520ND16ATBE	DIP	16	Tube	25
CD4520NS16ARDQ	SOP	16	Tape & Reel	4000
CD4520TS16ARDQ	TSSOP	16	Tape & Reel	4000

## 7. Package Information

### 7.1 DIP16

Dim.	mm.			inch.		
	Min.	Typ.	Max.	Min.	Typ.	Max.
a1	0.51			0.020		
B	0.77		1.65	0.030		0.065
b		0.5			0.020	
b1		0.25			0.010	
D			20			0.787
E		8.5			0.335	
e		2.54			0.100	
e3		17.78			0.700	
F			7.1			0.280
I			5.1			0.201
L		3.3			0.130	
Z			1.27			0.050

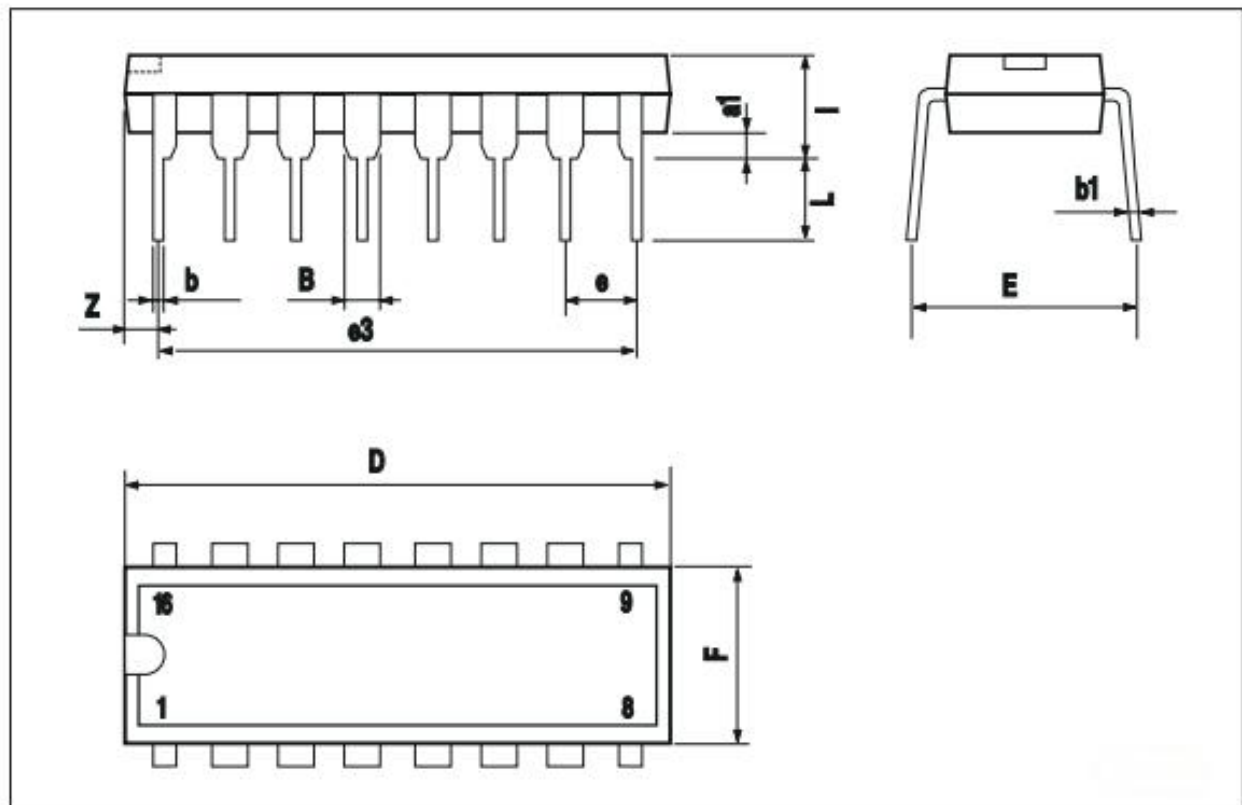

## 7.2 SOP16

Dim.	mm.			inch.		
	Min.	Typ.	Max.	Min.	Typ.	Max.
A			1.75			0.068
a1	0.1		0.25	0.004		0.010
a2			1.64			0.063
b	0.35		0.46	0.013		0.018
b1	0.19		0.25	0.007		0.010
C		0.5			0.019	
c1	45° (typ.)					
D	9.8		10	0.385		0.393
E	5.8		6.2	0.228		0.244
e		1.27			0.050	
e3		8.89			0.350	
F	3.8		4.0	0.149		0.157
G	4.6		5.3	0.181		0.208
L	0.5		1.27	0.019		0.050
M			0.62			0.024
S	8° (max.)					

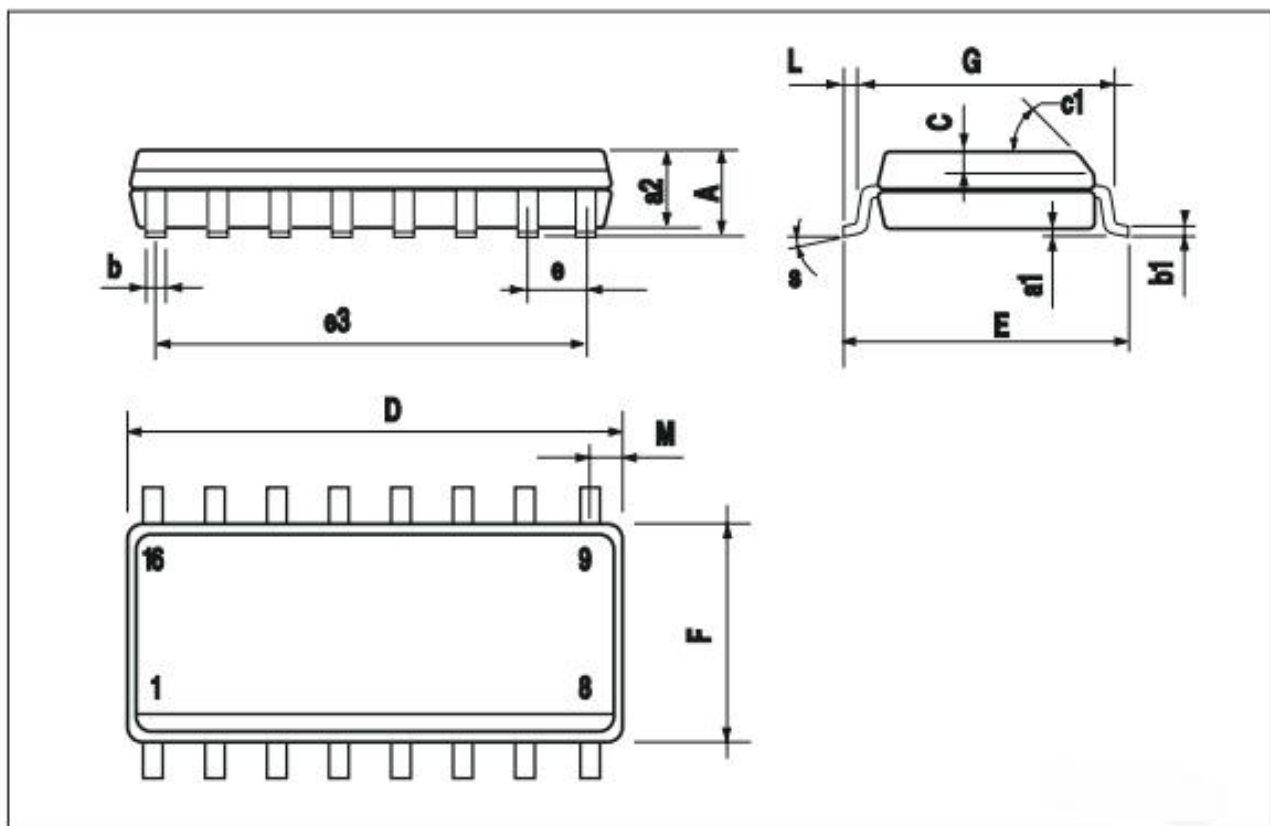



### 7.3 TSSOP16

Dim.	mm.			inch.		
	Min.	Typ.	Max.	Min.	Typ.	Max.
A			1.2			0.047
A1	0.05		0.15	0.002	0.004	0.006
A2	0.8	1	1.05	0.031	0.039	0.041
b	0.19		0.30	0.007		0.012
c	0.09		0.20	0.004		0.0079
D	4.9	5	5.1	0.193	0.197	0.201
E	6.2	6.4	6.6	0.244	0.252	0.260
E1	4.3	4.4	4.48	0.169	0.173	0.176
e		0.65 BSC			0.0256 BSC	
K	0°		8°	0°		8°
L	0.45	0.60	0.75	0.018	0.024	0.030

