



REV.	ECN NO OR DESCRIPTION	REVISED	DATE

技术要求:

- 1) 材质:见附表;
- 2) 电镀:见附表;
- 3) 塑件表面平整、光洁、无毛刺、气泡、烧焦、变形、浇口无拉伤、多料或缺料等不良现象;
- 4) 端子表面无氧化、电镀不良等现象。

适应基板厚度: 1.2mm~1.6mm

温度范围: -25℃~85℃

额定电压: 250V AC/DC

额定电流: 1A

绝缘电阻: ≥1000MΩ

耐压: 800V AC/minute

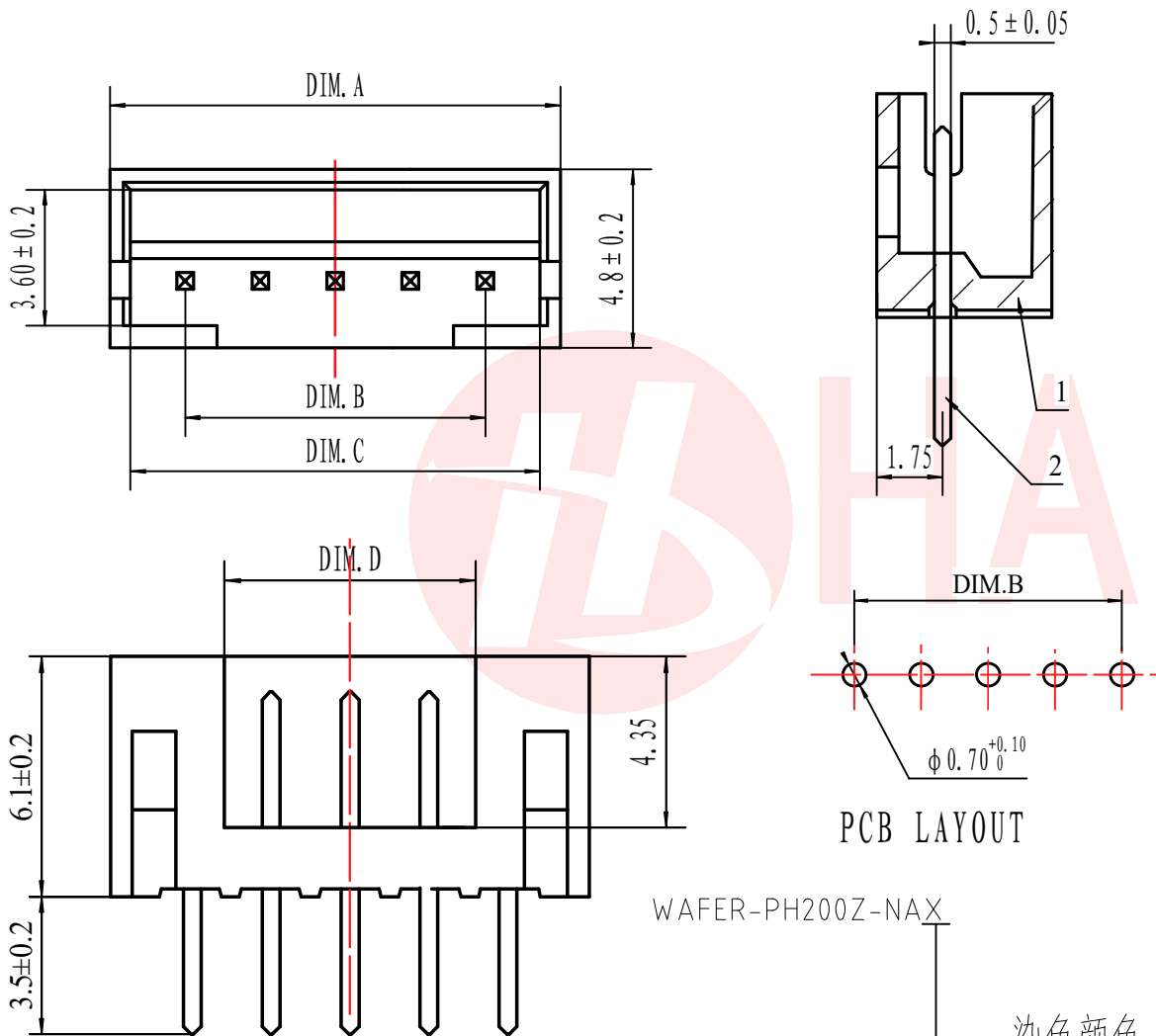

染色颜色
H:红色
L:蓝色

TABLE:

CSG PART NO.	PIN位	A	B	C	D
WAFER-PH200Z-2AX	2PIN	6.00	2.00	4.90	0.80
WAFER-PH200Z-3AX	3PIN	8.00	4.00	6.90	2.80
WAFER-PH200Z-4AX	4PIN	10.00	6.00	8.90	4.80
WAFER-PH200Z-5AX	5PIN	12.00	8.00	10.90	6.80
WAFER-PH200Z-6AX	6PIN	14.00	10.00	12.90	8.80
WAFER-PH200Z-7AX	7PIN	16.00	12.00	14.90	10.80
WAFER-PH200Z-8AX	8PIN	18.00	14.00	16.90	12.80
WAFER-PH200Z-9AX	9PIN	20.00	16.00	18.90	14.80
WAFER-PH200Z-10AX	10PIN	22.00	18.00	20.90	16.80
WAFER-PH200Z-11AX	11PIN	24.00	20.00	22.90	18.80
WAFER-PH200Z-12AX	12PIN	26.00	22.00	24.90	20.80
WAFER-PH200Z-15AX	15PIN	32.00	28.00	30.90	26.80

2	PIN	n PCS	材质:黄铜,电镀:镀亮锡60u*MIN
1	Housing	1 PCS	材质:PA66 (UL94V-0),颜色:本色
NO.	NAME	Q' TY	DESCRIPTION

UNLESS OTHERWISE SPECIFIED TOLERANCES

DECIMALS:	ANGLES:
X :±0.35	X :±2°
X.X :±0.25	X.X :±1°
X.XX :±0.15	



东莞市汉博电子科技有限公司
DONGGUAN HANBO TECHNOLOGY CO., LTD

TITLE	WAFER PH 2.00 直针(红蓝颜色)			
DWN	xiong	PART NO.WAFER-PH200Z-NAX		
CHKD	lee	SCALE:1:1	UNIT: mm	☉
APVD	wang	SIZE: A4	SHEET:1OF 1	REV: A4
CUSTOMER COPY				