

| REV. | DESCRIPTION | ECN NO. | NAME | DATE |
|------|-------------|---------|------|------|
| | | | | |

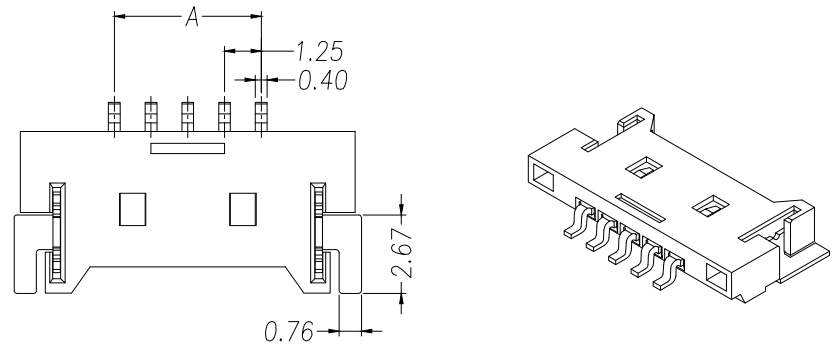

1
2
3
4
5

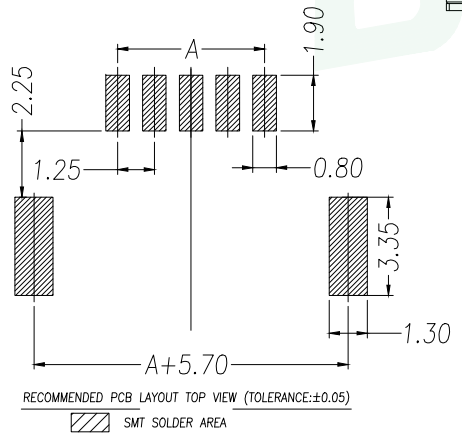
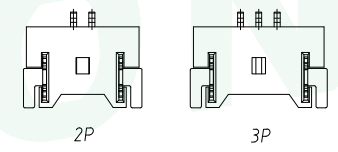
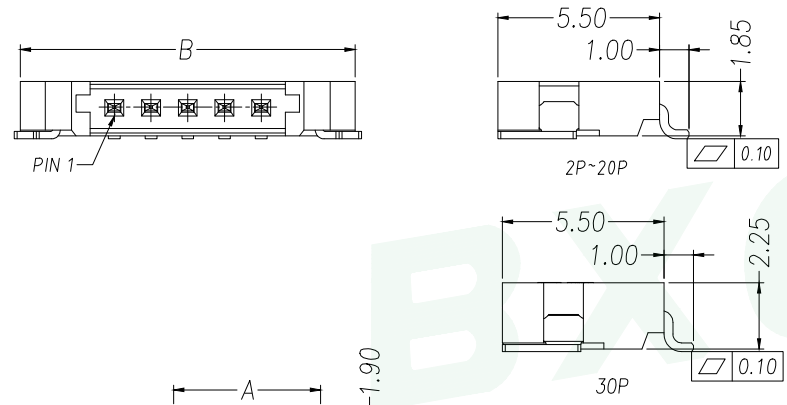

- NOTES:
- 1.Working temp:-25°C~85°C.
 - 2.Voltage rating:50V AC/DC(rms)
 - 3.Contact resistance:40mΩ max.
 - 4.Insulation resistance:100MΩ min.
 - 5.Current rating:1A AV/DC
 - 6.Withstanding Voltage:500V AC/minute
 - 7.Pin Retention Force:0.5N min.
 - 8.Housing material:PA9T UL94-V0,Natural
 - 9.Terminal materl:Brass,
plating Ni 40u" min , plating Au 0.8u"min.
 - 10.Solder tab material:Brass,
plating Ni 40u" min , plating Au 0.8u"min.

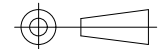

| PIN | NO. | Dim A | Dim B |
|-----|--------------|-------|-------|
| 2 | WF-1G125A2P | 1.25 | 7.65 |
| 3 | WF-1G125A3P | 2.50 | 8.90 |
| 4 | WF-1G125A4P | 3.75 | 10.15 |
| 5 | WF-1G125A5P | 5.00 | 11.30 |
| 6 | WF-1G125A6P | 6.25 | 12.65 |
| 7 | WF-1G125A7P | 7.50 | 13.90 |
| 8 | WF-1G125A8P | 8.75 | 15.15 |
| 9 | WF-1G125A9P | 10.00 | 16.40 |
| 10 | WF-1G125A10P | 11.25 | 17.65 |
| 11 | WF-1G125A11P | 12.50 | 18.90 |
| 12 | WF-1G125A12P | 13.75 | 20.15 |
| 13 | WF-1G125A13P | 15.00 | 21.40 |
| 14 | WF-1G125A14P | 16.25 | 22.65 |
| 15 | WF-1G125A15P | 17.50 | 23.90 |
| 20 | WF-1G125A20P | 23.75 | 30.15 |
| 30 | WF-1G125A30P | 36.25 | 42.65 |

| | | | | | | | | | |
|-------------------|-------|---|--|---------------|---------------|--|--|---------------|---------------|
| GENERAL TOLERANCE | | DONGGUAN BAOXUN PRECISION TECHNOLOGY CO., LTD | | | |   | | | |
| DIM. | TOL. | TITLE: 线对板针座 MX1.25 超薄 | | | | | | | |
| X | | DWG. NO.: WF-1G125ANP | | DRAWN: MAX | |  | | | |
| X.X | ±0.30 | PART NO.: WF-1G125ANP | | CHECKED: ELLA | | | | | |
| X.XX | ±0.25 | UNIT: mm | | SCALE: none | SHEET: 1 of 1 | | | DWG. SIZE: A4 | LAYER: bxconn |
| X.XXX | ±0.15 | GENERAL ANGLE: ±3° | | | | | | | |

| A | | B | | C | | D | | E | |
|------|-------------|---|--|---|---------|------|------|---|--|
| REV. | DESCRIPTION | | | | ECN NO. | NAME | DATE | | |

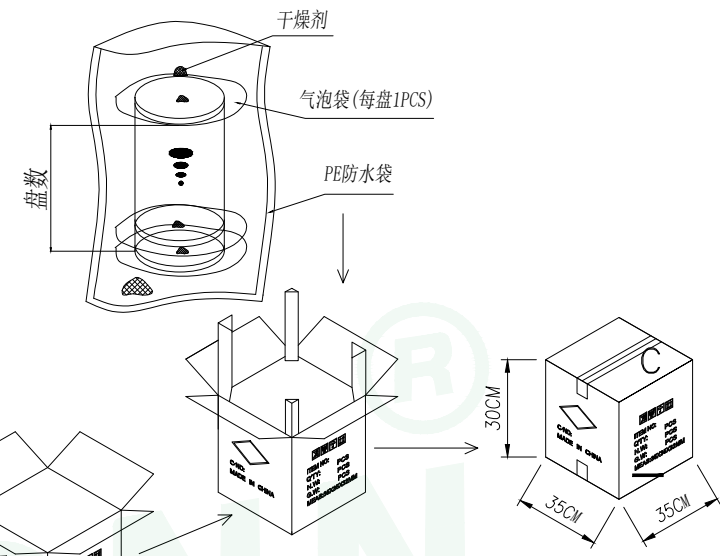
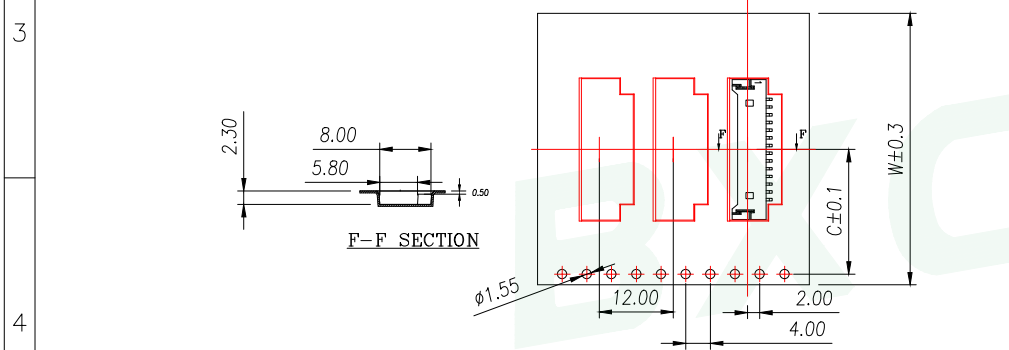
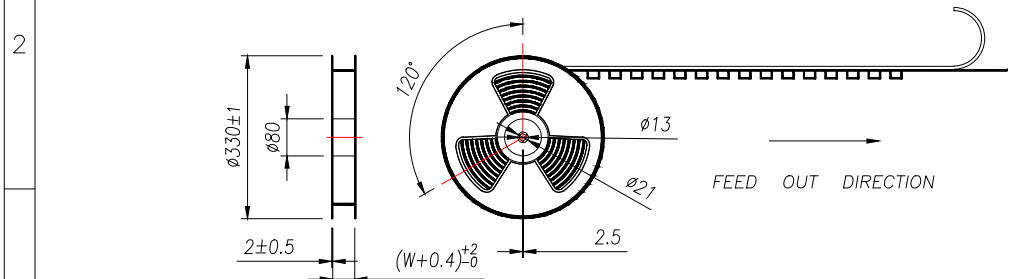
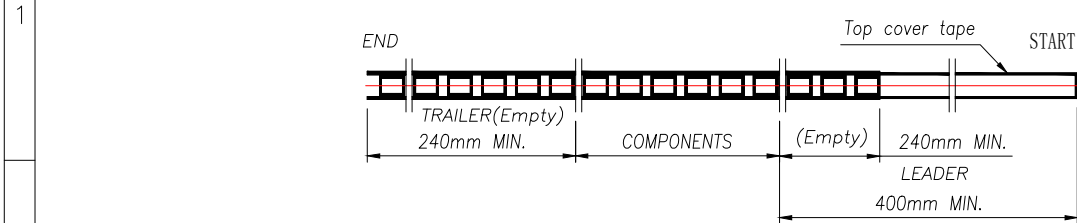

NOTE:
 1.10 SPROCKET HOLE PITCH CUMULATIVE TOLERANCE $\pm 0.2\text{mm}$.
 2.CARRIER CAMBER NOT TO EXCEED 1mm IN 100mm.
 3.ALL DIMENSIONS MEET EIA-481 REQUIREMENTS.
 4.MATERIAL: CLEAR ANTISTATIC PS, COLD SEALING.
 5.COMPONENT LOAD PER REEL: 2000 PCS.

| PIN | NO. | Dim C | Dim W | PCS/RELL | RELL/CARTON | PCS/CARTON |
|-----|-------------|-------|-------|----------|-------------|------------|
| 2 | WF-1G125A2P | 7.50 | 16.00 | 2000 | 12 | 24000 |
| 3 | WF-1G125A3P | | | | | |
| 4 | WF-1G125A4P | | | | | |
| 5 | WF-1G125A5P | 11.50 | 24.00 | 2000 | 10 | 20000 |
| 6 | WF-1G125A6P | | | | | |
| 7 | WF-1G125A7P | | | | | |
| 8 | WF-1G125A8P | | | | | |
| 9 | WF-1G125A9P | | | | | |

| | | | | | | |
|-------------------|---------------|---|---------------|----------------|---------------|--|
| GENERAL TOLERANCE | | DONGGUAN BAOXUN PRECISION TECHNOLOGY CO., LTD | | | | |
| DIM. TOL. | | TITLE: 线对板针座 MX1.25 超薄 | | | | |
| X | | DWG. NO.: WF-1G125ANP | | DRAWN: MAX | | |
| X.X | ± 0.30 | PART NO.: WF-1G125ANP | | CHECKED: ELLA | | |
| X.XX | ± 0.25 | UNIT: mm | | APPROVED: WILL | | |
| X.XXX | ± 0.15 | SCALE: none | SHEET: 1 of 1 | DWG. SIZE: A4 | LAYER: bxconn | |
| GENERAL ANGLE: | $\pm 3^\circ$ | | | | | |