

REV.	DESCRIPTION	ECN NO.	NAME	DATE

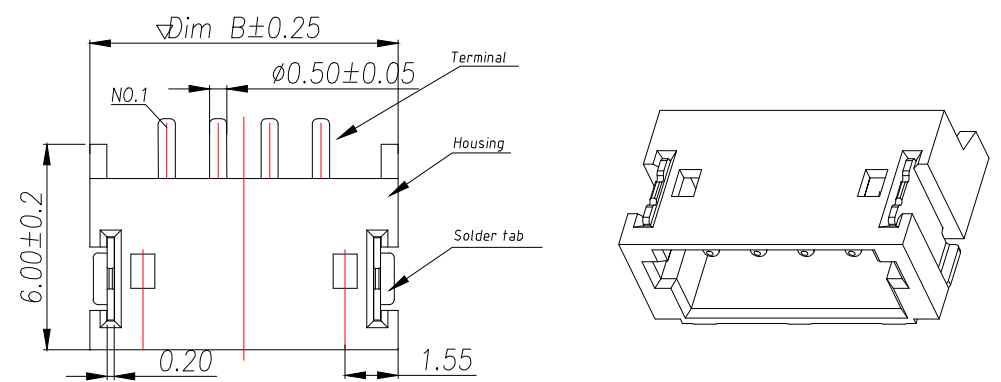

- NOTES::
- 1.Working temp:-25°C~85°C.
  - 2.Voltage rating:100V AV/DC(rms)
  - 3.Contact resistance:40mΩ max.
  - 4.Insulation resistance:500MΩ min
  - 5.Current rating:1A AV/DC
  - 6.Withstanding Voltage:500V AC/minute
  - 7.PIN Retention Force:10N min
  - 8.Housing material:LCP UL94-V0,Natural,
  - 9.Terminal mater:Brass C2680,  
plating Ni 50u" min , plating Tin 100u" min
  - 10.Solder tab material:Brass C2680,  
plating Ni 50u" min , plating Tin 100u" min
  - 11.MAJOR DIMENSION:

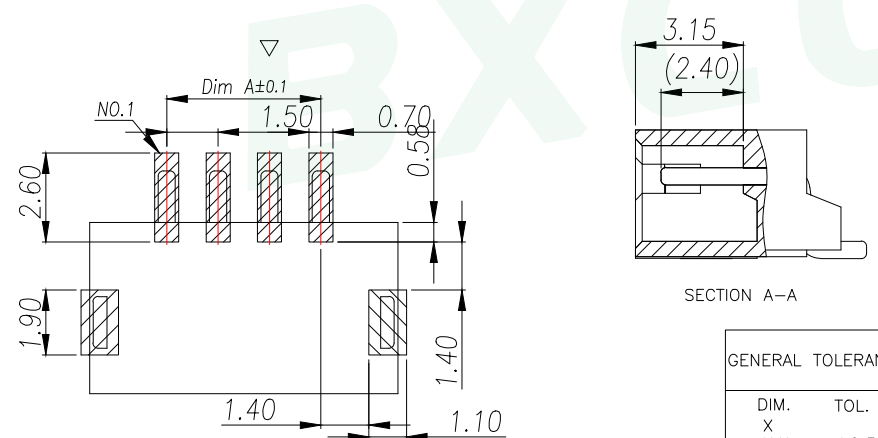
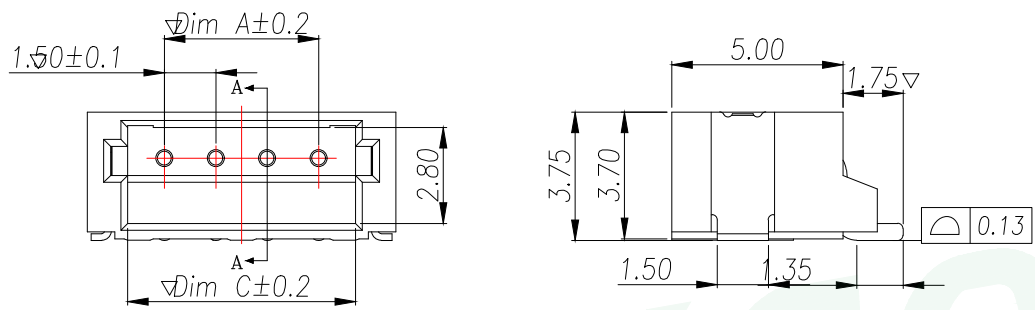

PIN	NO.	Dim A	Dim B	Dim C
2	WF-1F150A2P	1.50	6.00	3.65
3	WF-1F150A3P	3.00	7.50	5.15
4	WF-1F150A4P	4.50	9.00	6.65
5	WF-1F150A5P	6.00	10.50	8.15
6	WF-1F150A6P	7.50	12.50	9.65
7	WF-1F150A7P	9.00	13.50	11.15
8	WF-1F150A8P	10.50	15.50	12.65
9	WF-1F150A9P	12.50	16.50	14.15
10	WF-1F150A10P	13.50	18.50	15.65
11	WF-1F150A11P	15.50	19.50	17.15
12	WF-1F150A12P	16.50	21.50	18.65
13	WF-1F150A13P	18.50	22.50	20.15
14	WF-1F150A14P	19.50	24.50	21.65
15	WF-1F150A15P	21.50	25.50	23.15
16	WF-1F150A16P	22.50	27.50	24.65
17	WF-1F150A17P	24.50	28.50	26.15
18	WF-1F150A18P	25.50	30.00	27.65
19	WF-1F150A19P	27.50	31.50	29.15
20	WF-1F150A20P	28.50	33.00	30.65

RECOMMENDED PCB LAYOUT TOP VIEW (TOLERANCE:±0.05)

SMT SOLDER AREA

GENERAL TOLERANCE		DONGGUAN BAOXUN PRECISION TECHNOLOGY CO., LTD			
DIM.	TOL.	TITLE: 线对板针座 ZH1.5 卧式贴片			
X		DWG. NO.: WF-1F150ANP		DRAWN: MAX	
X.X	±0.30	PART NO.: WF-1F150ANP		CHECKED: ELLA	
X.XX	±0.25	UNIT: mm		SCALE: none	
X.XXX	±0.15	SHEET: 1 of 1		DWG. SIZE: A4	
GENERAL ANGLE:	±3°	LAYER: bxconn		APPROVED: WILL	

**BXCONN**<sup>®</sup>



REV.	DESCRIPTION	ECN NO.	NAME	DATE

1

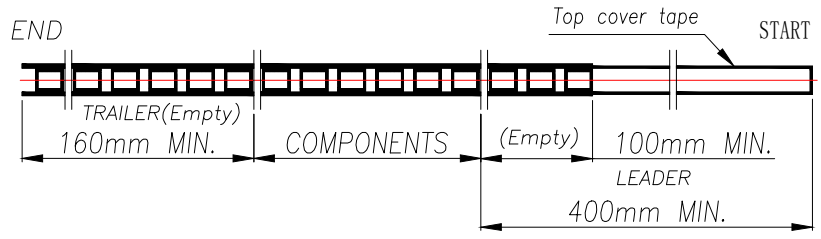

2

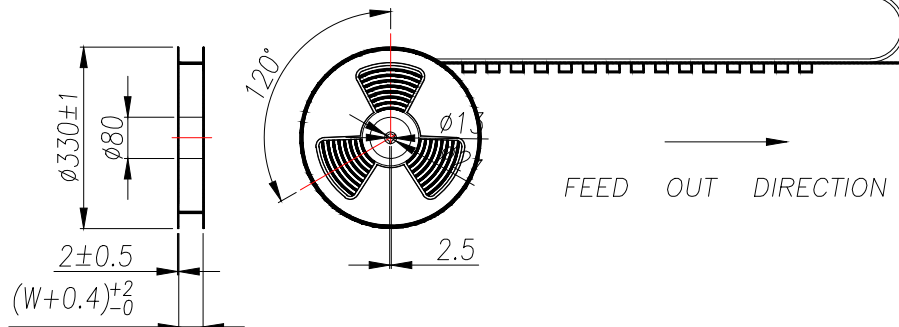

3

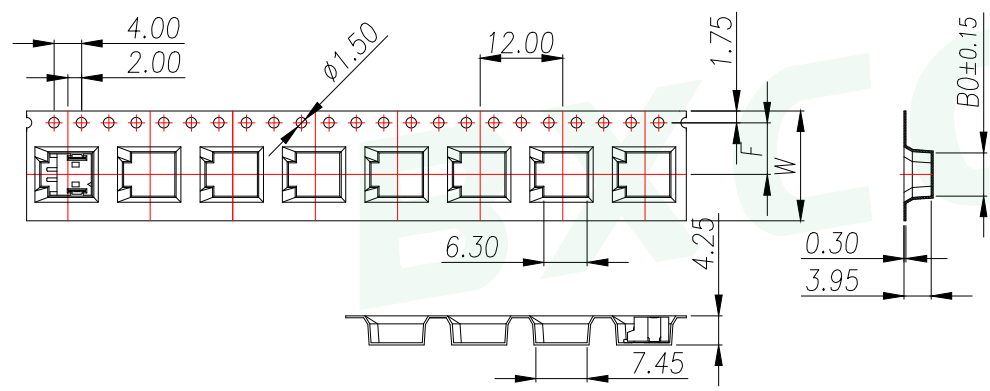

4

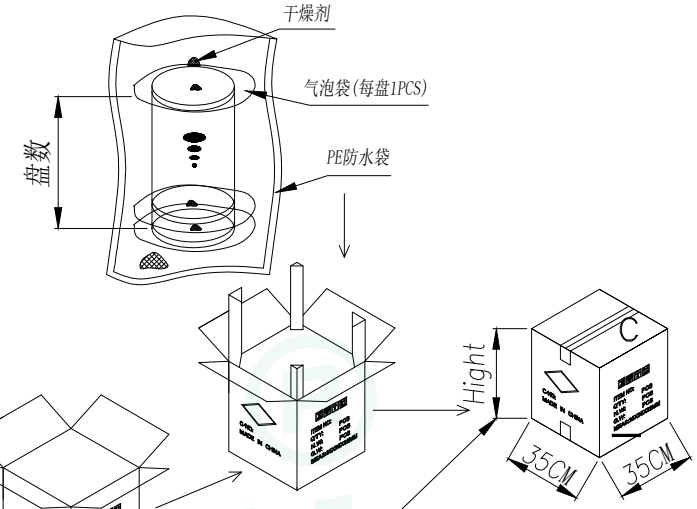

Carton Type	Small Size	Medium	Standard
Height(CM)	7.5	15	32

- NOTE:
- 1.10 SPROCKET HOLE PITCH CUMULATIVE TOLERANCE ±0.2mm.
  - 2.CARRIER CAMBER NOT TO EXCEED 1mm IN 100mm.
  - 3.ALL DIMENSIONS MEET EIA-481 REQUIREMENTS.
  - 4.MATERIAL: CLEAR ANTISTATIC PS. COLD SEALING.
  - 5.THICKNESS: 0.30±0.05mm.
  - 6.PACKING LENGTH PER REEL: 12.5 METERS.
  - 7.COMPONENT LOAD PER REEL: 1000 PCS.

5

PIN	NO.	Dim B0	Dim W	Dim F	PCS/RELL	RELL/CARTON	PCS/CARTON
2	WF-1F150A2P	6.30	16	7.5	1000	14	14000
3	WF-1F150A3P	7.80	24	11.5		10	10000
4	WF-1F150A4P	9.30					
5	WF-1F150A5P	10.80					
6	WF-1F150A6P	12.30					
7	WF-1F150A7P	13.80					
8	WF-1F150A8P	15.30					

GENERAL TOLERANCE		DONGGUAN BAOXUN PRECISION TECHNOLOGY CO., LTD			
DIM.	TOL.	TITLE: 线对板针座 ZH1.5 卧式贴片			
X		DWG. NO.: WF-1F150ANP		DRAWN: MAX	
X.X	±0.30	PART NO.: WF-1F150ANP		CHECKED: ELLA	
X.XX	±0.25	UNIT: mm		APPROVED: WILL	
X.XXX	±0.15	SCALE: none	SHEET: 1 of 1	DWG. SIZE: A4	LAYER: bxconn
GENERAL ANGLE:	±3°				

**BXCONN**<sup>®</sup>

REV.	DESCRIPTION	ECN NO.	NAME	DATE

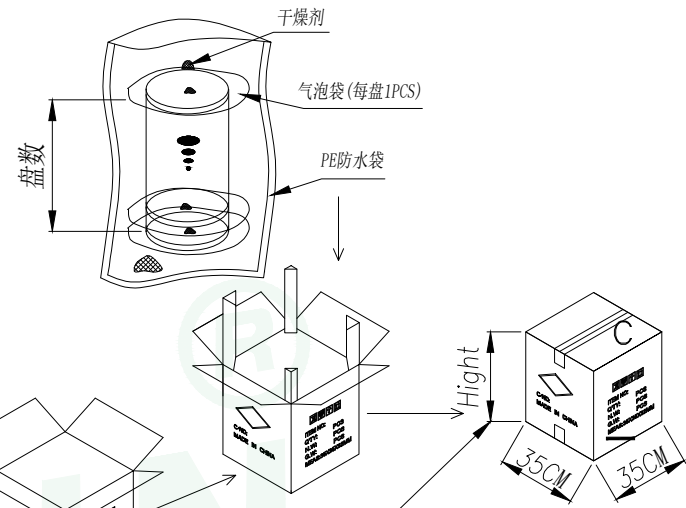
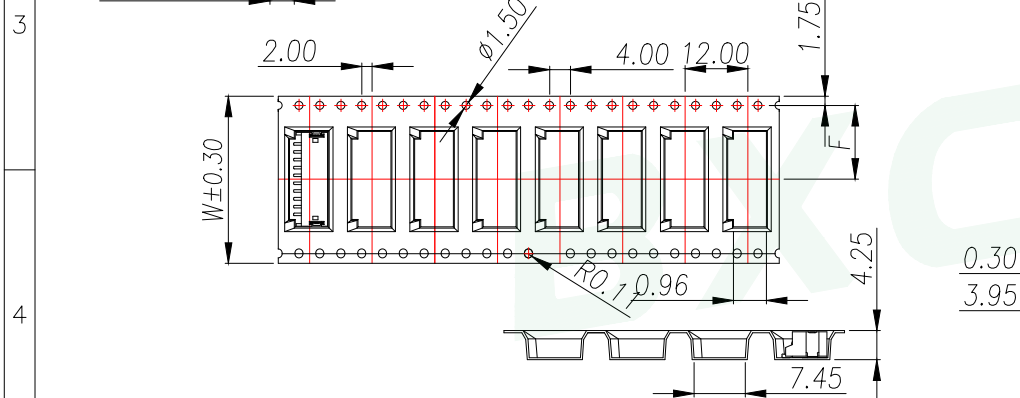
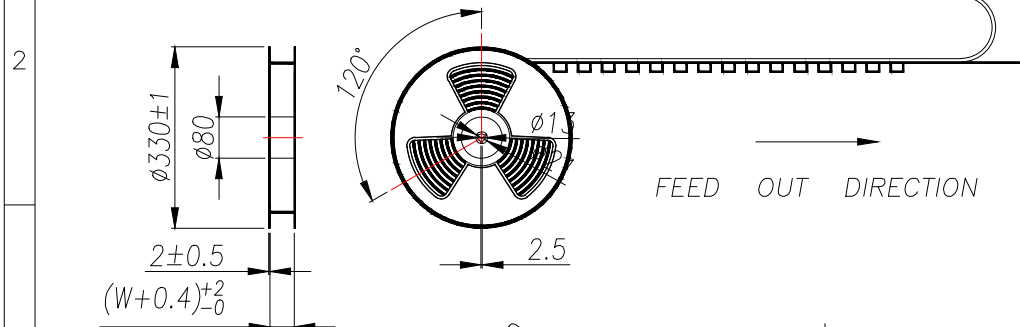
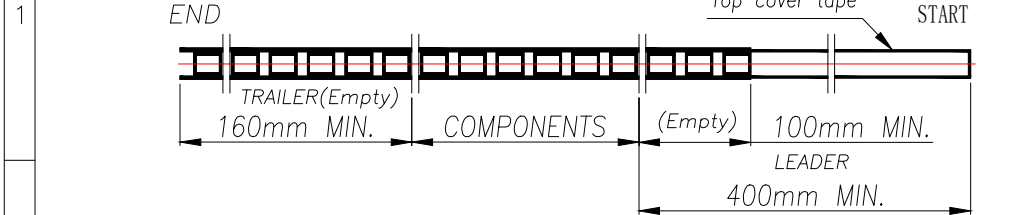

Carton Type	Small Size	Medium	Standard
Hight(CM)	7.5	15	32

- NOTE:
- 1.10 SPROCKET HOLE PITCH CUMULATIVE TOLERANCE  $\pm 0.2\text{mm}$ .
  - 2.CARRIER CAMBER NOT TO EXCEED 1mm IN 100mm.
  - 3.ALL DIMENSIONS MEET EIA-481 REQUIREMENTS.
  - 4.MATERIAL: CLEAR ANTISTATIC PS. COLD SEALING.
  - 5.THICKNESS:  $0.30 \pm 0.05\text{mm}$ .
  - 6.PACKING LENGTH PER REEL: 12.5 METERS.
  - 7.COMPONENT LOAD PER REEL: 1000 PCS.

PIN	NO.	Dim B0	Dim W	Dim F	PCS/RELL	RELL/CARTON	PCS/CARTON
9	WF-1F150A9P	16.80	32	14.2	1000	8	8000
10	WF-1F150A10P	18.30					
11	WF-1F150A11P	19.80					
12	WF-1F150A12P	21.30					
13	WF-1F150A13P	22.80	44	20.2		6	6000
14	WF-1F150A14P	24.30					
15	WF-1F150A15P	25.80					
16	WF-1F150A16P	27.30					

GENERAL TOLERANCE		DONGGUAN BAOXUN PRECISION TECHNOLOGY CO., LTD			
DIM.	TOL.	TITLE: 线对板针座 ZH1.5 卧式贴片			
X		DWG. NO.: WF-1F150ANP		DRAWN: MAX	
X.X	$\pm 0.30$	PART NO.: WF-1F150ANP		CHECKED: ELLA	
X.XX	$\pm 0.25$	UNIT: mm		APPROVED: WILL	
X.XXX	$\pm 0.15$	SCALE: none	SHEET: 1 of 1	DWG. SIZE: A4	LAYER: bxconn
GENERAL ANGLE:	$\pm 3^\circ$				

