



REV.	ECN NO OR DESCRIPTION	REVISED	DATE

技术要求:

- 1) 材质: 见附表;
- 2) 电镀: 见附表;
- 3) 塑件表面平整、光洁、无毛刺、气泡、烧焦、变形、浇口无拉伤、多料或缺料等不良现象;
- 4) 端子表面无氧化、电镀不良等现象。

适应基板厚度: 1.2mm~1.6mm

温度范围: -25°C~85°C

额定电压: 250V AC/DC

额定电流: 1A

绝缘电阻: $\geq 1000M\Omega$

耐压: 800V AC/minute

TABLE:

CSG PART NO.	PIN位	A	B	C	D
WAFER-PH200WZ-2AX	2PIN	6.00	2.00	4.90	0.80
WAFER-PH200WZ-3AX	3PIN	8.00	4.00	6.90	2.80
WAFER-PH200WZ-4AX	4PIN	10.00	6.00	8.90	4.80
WAFER-PH200WZ-5AX	5PIN	12.00	8.00	10.90	6.80
WAFER-PH200WZ-6AX	6PIN	14.00	10.00	12.90	8.80
WAFER-PH200WZ-7AX	7PIN	16.00	12.00	14.90	10.80
WAFER-PH200WZ-8AX	8PIN	18.00	14.00	16.90	12.80
WAFER-PH200WZ-9AX	9PIN	20.00	16.00	18.90	14.80
WAFER-PH200WZ-10AX	10PIN	22.00	18.00	20.90	16.80
WAFER-PH200WZ-11AX	11PIN	24.00	20.00	22.90	18.80
WAFER-PH200WZ-12AX	12PIN	26.00	22.00	24.90	20.80
WAFER-PH200WZ-15AX	15PIN	32.00	28.00	30.90	26.80

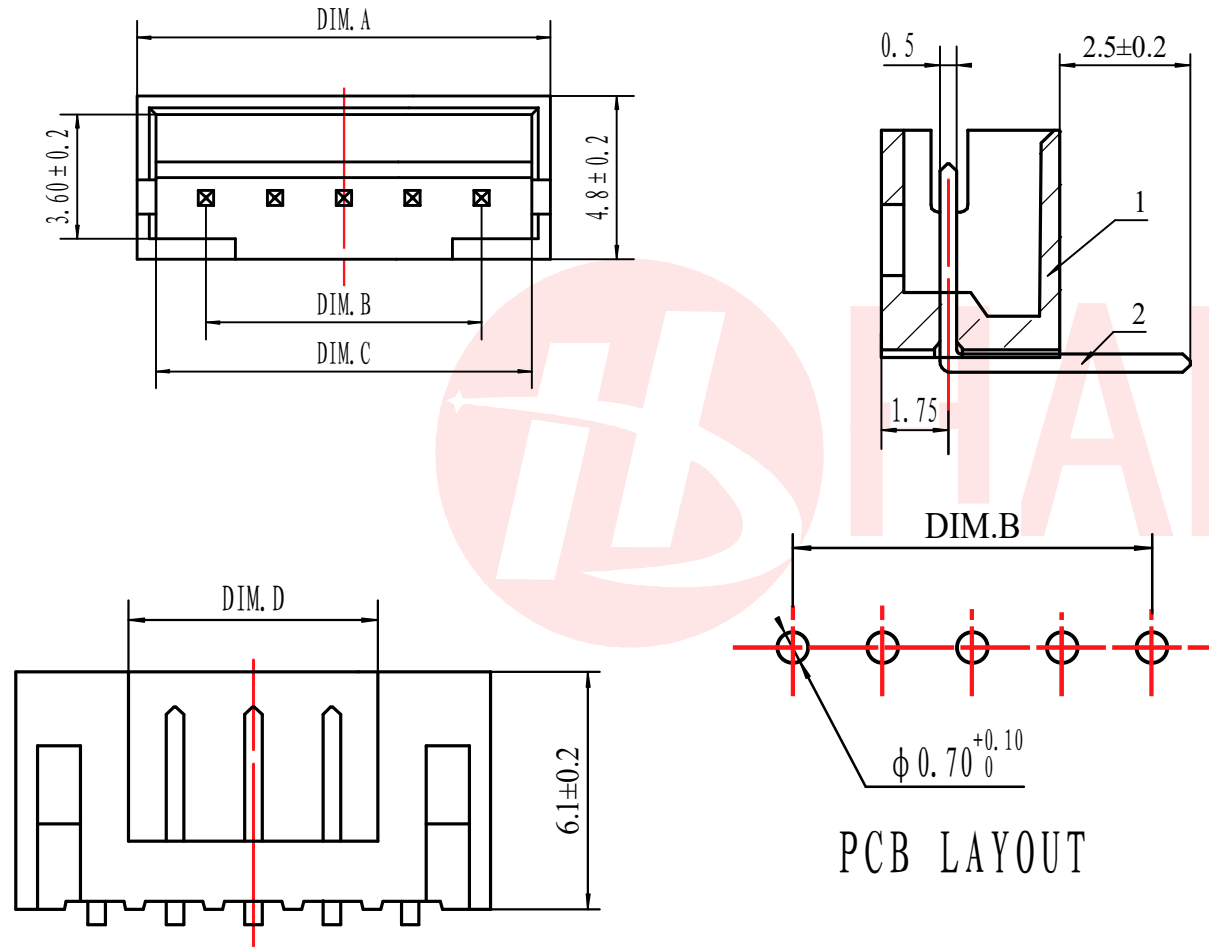

WAFER-PH200WZ-NAX

染色颜色
H: 红色
L: 蓝色

UNLESS OTHERWISE SPECIFIED TOLERANCES

DECIMALS: ANGLES:
X :±0.35 X :±2°
X.X :±0.25 X.X :±1°
X.XX :±0.15



东莞市汉博电子科技有限公司
DONGGUAN HANBO TECHNOLOGY CO., LTD

TITLE	WAFER PH 2.00 弯针(红蓝颜色)			
DWN	xiong	PART NO.WAFER-PH200WZ-NAX		
CHKD	lee	SCALE:1:1	UNIT: mm	
APVD	wang	SIZE: A4	SHEET:10F 1	REV: A4

CUSTOMER COPY