

PCB LAYOUT

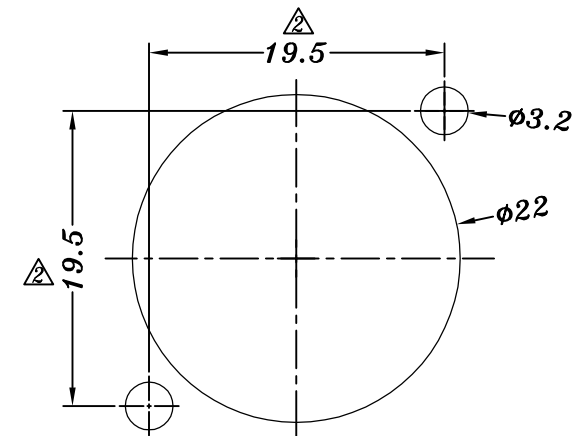

PANEL LAYOUT

| | | | | | | | | | | | |
|-----|-------------------------|----------|-----|-----------|-----------------|----------------------|------------|-------------------------------|----------------|------|---------|
| | | | | | | A4 | 2024.04.13 | 修正尺寸公差, 新增尺寸管控 | GYW | | |
| | | | | | | A3 | 2022.05.07 | 客诉引脚上锡不良, 脚长5.2改短至3.5 | GYW | | |
| | | | | | | A2 | 2018.11.29 | 依据生产现状修正尺寸19.8至19.5 4.0改为3.5 | GYW | | |
| | | | | | | A1 | 2017.5.19 | 尺寸19.8公差由±0.2改为±0.3, 尺寸4改为3.8 | PWJ | | |
| | | | | | | NO | DATE | REVISIONS | BY | APPD | |
| 5 | DIN324D 4#CONTACT PIECE | BRASS | 1 | Ni PLATED | UP TO 5mm: ±0.1 | TITLE: XLR CONNECTOR | | UNIT : MM | ROHS COMPLIANT | DWN | |
| 4 | DIN324 G SPRING | PBS | 1 | Ni PLATED | ANGULAR | MODEL: DIN-324D | | SCALE: 2:1 | CHK'D | | |
| 3 | DIN324E 3#PING | BRASS | 1 | Au PLATED | ±1° | 东莞市六钧电子五金有限公司 | | APPD | | | |
| 2 | DIN324E 1#, 2#PING | BRASS | 2 | Au PLATED | | | | PRO.AGL: | PROJ | | |
| 1 | DIN324 CASE | PA66 | 1 | | | | | | | | REV :A4 |
| NO. | PART NAME | MATERIAL | QTY | FINISHING | | | | | | | |