



深圳市韩下电子有限公司

Shenzhen Hanxia Electronic Co., Ltd
Tel: 0755-33819206 Fax: 0755-27597491

承 认 书

SPECIFICATION FOR APPROVAL

客 户 Customer:

产品名称 Project:

磁环

规格型号 Part No:

HX 2132-1130-BK-110B

贵公司承认印 Approval signatures



料 号/Part No.	签 章/Signatures

日期 Date:

拟制/Drawn	黄彬	
审核/Check	张伟	
批准/Approved	罗小春	



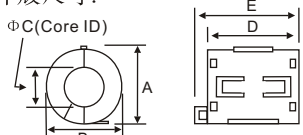
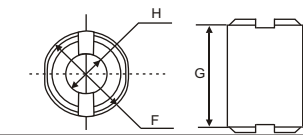

承 認 書 SPECIFICATION FOR APPROVAL

客户名稱 CUSTOMER		日期 DATE	2022.02.23										
規 格 ITEM	HX 2132-1130-BK-110B	編 號 SERIAL NO.											
1.1. 形狀尺寸(單位/毫米): SHAPE & DIMENSION(unit/mm): 1.2. 實物圖: The Sample::		A	20.5 ± 1.0 mm										
外殼尺寸: 		B	20.5 ± 1.0 mm										
磁芯尺寸: 		C	11 ± 0.8 mm										
		D	32 ± 1.0 mm										
		E	36 ± 1.0 mm										
		F	17 ± 0.5 mm										
		G	28 ± 0.7 mm										
		H	11 ± 0.4 mm										
2. 電氣性能檢測項目: ELECTRICAL REQUIREMENTS:		測試儀器 TEST INSTRUMENTS											
<input type="checkbox"/> L		TEST FREQ	KHZ MHZ										
<input type="checkbox"/> Q		TEST FREQ	KHZ MHZ										
<input checked="" type="checkbox"/> Z	Z1= 50Ω MIN	KHZ 25MHZ	Z2=100Ω MIN										
	Z3= /	KHZ MHZ	Z4= /										
溫度 TEMP	℃	濕 度 HUMIDITY	%										
綫 組 WINDING	Φ0.5x0.5TSx100L(mm)												
3. 磁芯外觀: THE LIMIT OF CORE BREAKAGE:													
<table border="1"> <thead> <tr> <th>項 目 Item</th> <th>標準值 Standard Value</th> </tr> </thead> <tbody> <tr> <td>一處缺陷的面積 Area of a breakage</td> <td>≤2mm²</td> </tr> <tr> <td>總缺陷面積 All area of the breakage</td> <td>≤2mm²</td> </tr> <tr> <td>缺陷深度 The depth of the breakage</td> <td>≤0.4mm</td> </tr> <tr> <td>毛刺長度 The length of burr</td> <td>≤0.2mm</td> </tr> </tbody> </table>		項 目 Item	標準值 Standard Value	一處缺陷的面積 Area of a breakage	≤2mm ²	總缺陷面積 All area of the breakage	≤2mm ²	缺陷深度 The depth of the breakage	≤0.4mm	毛刺長度 The length of burr	≤0.2mm		
項 目 Item	標準值 Standard Value												
一處缺陷的面積 Area of a breakage	≤2mm ²												
總缺陷面積 All area of the breakage	≤2mm ²												
缺陷深度 The depth of the breakage	≤0.4mm												
毛刺長度 The length of burr	≤0.2mm												

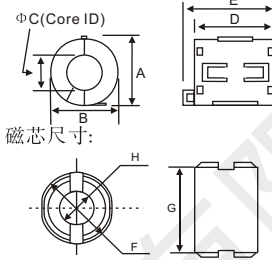
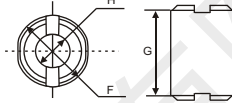

深圳市韩下电子有限公司

檢驗數據 INSPECTION DATA

客戶名稱 CUSTOMER				日期 DATE	2022.02.23	數量 QUANTITY	10PCS
編號 SERIAL NO.				形狀尺寸(單位/毫米): SHAPE & DIMENSION(unit/mm): 外殼尺寸:  磁芯尺寸: 	實物圖: The Sample:: 		
規格 ITEM	HX 2132-1130-BK-110B						
綫組 WINDING	Φ0.5x0.5TSx100L(mm)						
測試頻率 TEST FREQ	Z1= 25 KHZ MHZ	Z2= 100 KHZ MHZ	Z3= KHZ MHZ		Z4= KHZ MHZ		
溫度 TEMP	℃	濕度 HUMIDITY	%				

項目 TEST ITEM	電氣性能 ELECTRIC CHARACTERISTICS				尺寸(單位:毫米) DIMENSION(unit:mm)							
	Z1(Ω)	Z2(Ω)	Z3(Ω)	Z4(Ω)	A	B	C	D	E	F	G	H
		50	100			20.5	20.5	11	32	36	17	28
+	/	/			1.0	1.0	0.8	1.0	1.0	0.5	0.7	0.4
-	0	0			1.0	1.0	0.8	1.0	1.0	0.5	0.7	0.4
1	64.8	137.8			20.10	20.11	11.21	32.10	36.06	17.10	28.21	11.10
2	65.0	137.0			19.90	19.98	11.15	32.15	36.05	16.90	28.15	11.15
3	64.7	136.7			20.05	20.04	11.23	32.13	36.08	17.05	28.23	11.13
4	64.9	135.5			20.06	20.07	11.23	32.16	36.06	17.06	28.23	11.16
5	65.7	135.7			19.99	19.96	11.22	32.12	36.05	16.99	28.22	11.12
6	64.9	138.6			19.96	19.95	11.23	32.09	36.07	16.96	28.23	11.09
7	65.3	138.2			20.04	20.05	11.20	32.14	36.05	17.04	28.20	11.14
8	65.4	137.6			20.01	20.03	11.16	32.12	36.04	17.01	28.16	11.12
9	64.9	135.8			20.07	20.04	11.24	32.08	36.07	17.07	28.24	11.08
10	64.2	136.4			19.98	19.97	11.18	32.07	36.06	16.98	28.18	11.07
\bar{X}	64.98	136.93			20.02	20.02	11.2	32.1	36.06	17.01	28.20	11.11
Y/N	Y	Y			Y	Y	Y	Y	Y		Y	Y

測試儀器:
TEST INSTRUMENTS:
E4991A+16194A

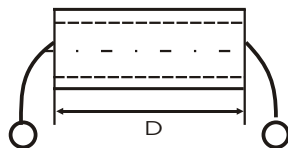

檢驗 INSPECTED	復核 CHECKED	確認 APPROVED
龙云辉	张伟	罗小春



阻抗 - 频率曲线 IMPEDANCE V.S FREQUENCY (Z-Y)

客户名稱 CUSTOMER		日期 DATE	2022.02.23
規格 ITEM	HX 2132-1130-BK-110B	編號 SERIAL NO.	

材質特性 MATERIAL CHARACTERISTICS

材料牌號 Material	初始磁導率 Initial Permeability	比損耗因子 Relative Loss Factor	比溫度係數 Relative Temperature Coefficient	飽和磁通密度 Saturation Magnetic Flux Density	剩磁 Remanence	矯頑力 Coercivity	居裏溫度 Curie Temperature	電阻率 Electrical Resistivity	密度 Density
Unit symbol	μ_i $\pm 20\%$	$\tan \delta / \mu_i$ $\times 10^{-6}$	$\alpha \mu_i / \%$ $\times 10^{-6}$	Bs (MT)	Br (MT)	HC (A/m)	Tc (°C)	ρ ($\Omega \cdot m$)	d (g/cm ³)
F9	850	16 (0.1MHz)	5 - 10	280(1600A/m)	200	20	>130	>10 ⁵	4.6

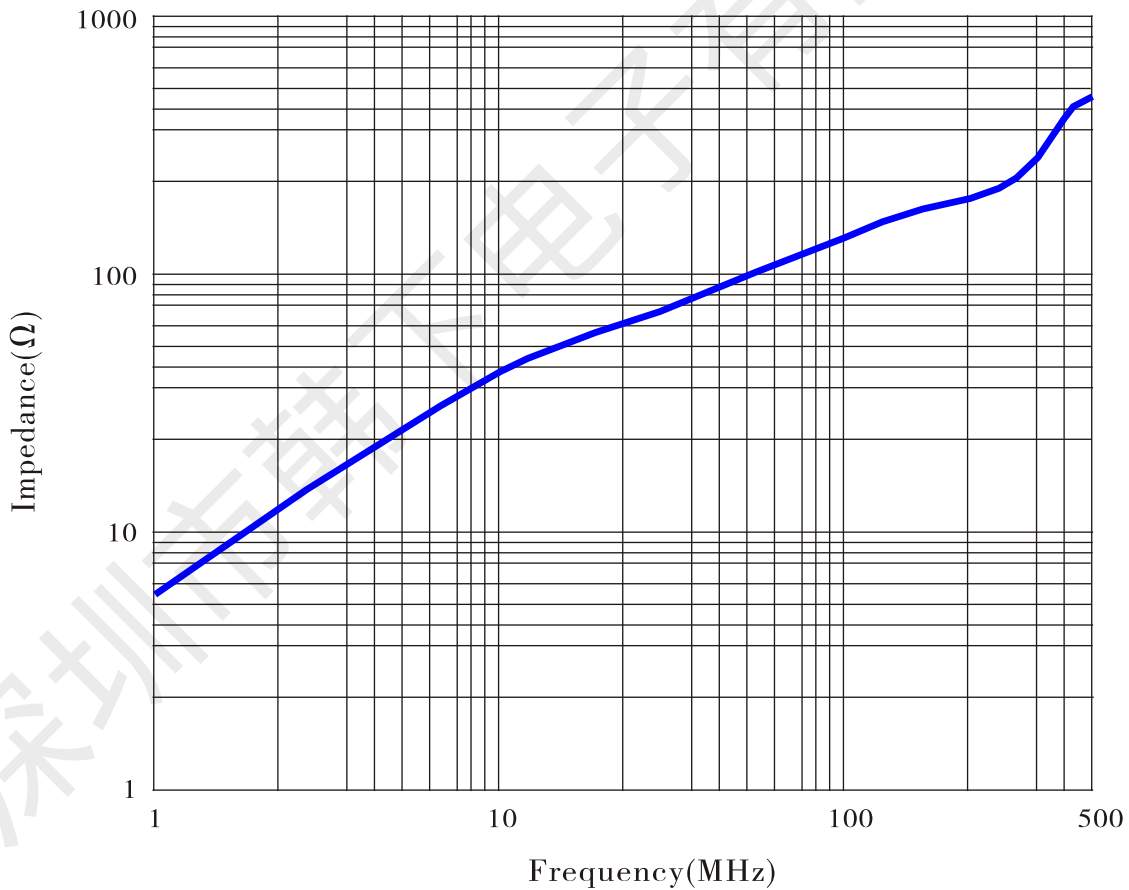

測試條件：
TESTING CONDITION:

- 測試儀器：
Testing Equipment: E4991A+16194A
- 測試頻率區間：
Testing Frequency Range: 1-500MHz
- 測試線組：
Testing Coil Specification: $\Phi 0.5 \times 0.5 \text{TS} \times 100 \text{L} (\text{mm})$

測試 TESTED	復核 CHECKED	確認 APPROVED
龙云辉	张 伟	罗小春