



BCT1901

Quad-Output, 2x1.2A, 2x2A Synchronous Step-Down Converter

BCT1901

Quad-Output, 2x1.2A, 2x2A, Synchronous Step-Down Converter

GENERAL DESCRIPTION

The BCT1901 is composed of four synchronous DC-DC step-down converter, The first and the fourth converter are the same Chip which capable of delivering up to 1.2A output current. The second and the third converter are the same Chip which capable of delivering up to 2A output current. The BCT1901 operate over a wide input voltage range from 2.7V to 5.5V and with a high switching frequency.

The 100% duty cycle feature provides low dropout operation, extending battery life in portable systems. The internal synchronous switch increases efficiency and eliminates the need for external Schottky diode. Each converter may also be shut down independently with its own shutdown pin. At shutdown mode, the Each converter input supply current is less than 1µA.

The BCT1901 integrates current limit, output Short protection and thermal protection.

The BCT1901 is available in a QFN4x4-24L package, which provides a compact solution with minimal external components.

ORDERING INFORMATION

Order Number	Package Type	Temperature Range	Marking	QTY/Reel
BCT1901EGG-TR	QFN4x4-24L	-40°C to +85°C	SCCK9005H XXXXXX XXXXXX	3000

Note: "XXXXXX " in Marking will be appeared as the batch code.

FEATURES

- Quad-output Voltages
- 2.7V~5.5V Input Voltage Range
- 2x1.2A and 2x2A Output Current
- high Switching Frequency Minimizes the External Components
- Up to 95% efficiency
- 100% Duty Cycle in Dropout Operation
- Output Voltage as Low as 0.6V (Each Output)
- No Schottky Diode Required
- Internal soft-start
- Output short protection
- Output Auto-Discharge When EN Low
- Thermal protection
- QFN4x4-24L Packages

PIN CONFIGURATION (Top View)

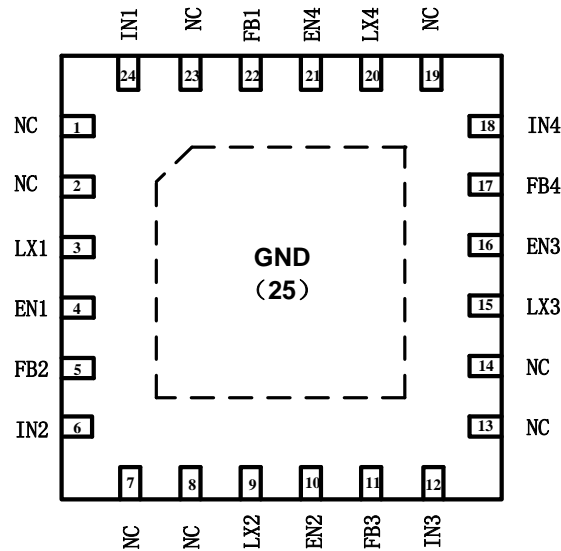

PIN DESCRIPTION

PIN	NAME	FUNCTION
1,2,7,8,13,14,19,23	NC	No Connect
3	LX1	Power Switching Output of regulator 1. Connect an inductor to the drains of internal high side PMOS and low side NMOS.
4	EN1	Enable Pin of regulator 1. Active High
5	FB2	Output feedback pin of regulator 2. FB senses the output voltage and is regulated by the control loop to 0.6V. Connect a resistive divider at FB.
6	IN2	Power Supply Input of regulator 2.
9	LX2	Power Switching Output of regulator 2. Connect an inductor to the drains of internal high side PMOS and low side NMOS.
10	EN2	Enable Pin of regulator 2. Active High
11	FB3	Output feedback pin of regulator 3. FB senses the output voltage and is regulated by the control loop to 0.6V. Connect a resistive divider at FB.
12	IN3	Power Supply Input of regulator 3.



BCT1901

Quad-Output, 2x1.2A, 2x2A Synchronous Step-Down Converter

PIN	NAME	FUNCTION
15	LX3	Power Switching Output of regulator 3. Connect an inductor to the drains of internal high side PMOS and low side NMOS.
16	EN3	Enable Pin of regulator 3. Active High
17	FB4	Output feedback pin of regulator 4. FB senses the output voltage and is regulated by the control loop to 0.6V. Connect a resistive divider at FB.
18	IN4	Power Supply Input of regulator 4.
20	LX4	Power Switching Output of regulator 4. Connect an inductor to the drains of internal high side PMOS and low side NMOS.
21	EN4	Enable Pin of regulator 4. Active High
22	FB1	Output feedback pin of regulator 1. FB senses the output voltage and is regulated by the control loop to 0.6V. Connect a resistive divider at FB.
24	IN1	Power Supply Input of regulator 1.
25	GND	Ground, Thermal pin.

Typical Operating Circuit

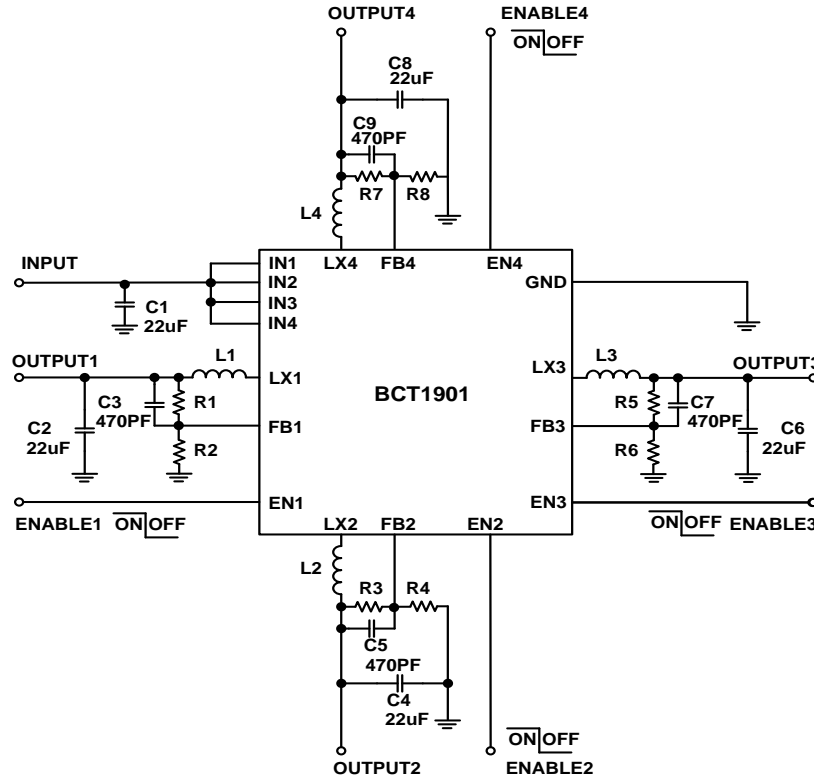

ABSOLUTE MAXIMUM RATINGS

Input Supply Voltage.....	-0.3V to 6.5V
ENn, FBn ,SWn PIN	-0.3V to VIN+0.3V
Storage Temperature Range.....	-65°C to +150°C
Junction Temperature.....	150°C
Operating Temperature Range.....	-40°C to +85°C
Lead Temperature (Soldering, 10 sec).....	260°C
Package Thermal Resistance(θ_{JA})	
QFN4x4-24L.....	39.7°C/W

NOTE:

Stresses beyond those listed under “Absolute Maximum Ratings” may cause permanent damage to the device. These are stress ratings only, and functional operation of the device at these or any other conditions beyond those indicated in the operational sections of the specifications is not implied. Exposure to absolute maximum rating conditions for extended

CAUTION

periods may affect device reliability.

This integrated circuit can be damaged by ESD if you don't pay attention to ESD protection. Broadchip recommends that all integrated circuits be handled with appropriate precautions. Failure to observe proper handling and installation procedures can cause damage. ESD damage can range from subtle performance degradation to complete device failure. Precision integrated circuits may be more susceptible to damage because very small parametric changes could cause the device not to meet its published specifications.

Broadchip reserves the right to make any change in circuit design, specification or other related things if necessary without notice at any time. Please contact Broadchip sales office to get the latest datasheet.



BCT1901

Quad-Output, 2x1.2A, 2x2A

Synchronous Step-Down Converter

ELECTRICAL CHARACTERISTICS

(VIN= 5V, TA = 25°C, Both A⁽¹⁾ and B⁽²⁾ chip are applicable unless otherwise specified.)

PARAMETER	SYM	CONDITIONS	MIN	TYP	MAX	UNITS
V _{IN} Input Supply Voltage	V _{IN}		2.7		5.5	V
V _{IN} UVLO Threshold	V _{IN_MIN}	V _{IN} Rising		2.4		V
V _{IN} Under Voltage Lockout Threshold Hysteresis	V _{IN_MIN_HYST}	V _{IN} Falling		200		mV
Shutdown Supply Current	I _{SD}	V _{EN} =0V			1	uA
Supply Current @ A ⁽¹⁾	I _Q	V _{EN} =5V, V _{FB} =0.63V		40		uA
Supply Current @ B ⁽²⁾	I _Q	V _{EN} =5V, V _{FB} =0.63V		55		uA
Feedback Voltage	V _{FB}		0.585	0.600	0.615	V
Top Switch On-Resistance @ A ⁽¹⁾	R _{DS(ON)T}			200		mΩ
Top Switch On-Resistance @ B ⁽²⁾	R _{DS(ON)T}			110		mΩ
Bottom Switch On-Resistance @ A ⁽¹⁾	R _{DS(ON)B}			150		mΩ
Bottom Switch On-Resistance @ B ⁽²⁾	R _{DS(ON)B}			80		mΩ
Switch Frequency @ A ⁽¹⁾	F _{SW}			1.5		MHz
Switch Frequency @ B ⁽²⁾	F _{SW}			1.0		MHz
Top Switch Current Limit @ A ⁽¹⁾	I _{LIM_TOP}			1.8		A
Top Switch Current Limit @ B ⁽²⁾	I _{LIM_TOP}			3.5		A
Max Duty Cycle			100			%
Minimum On Time @ A ⁽¹⁾	T _{ON_MIN}			100		ns
Minimum On Time @ B ⁽²⁾	T _{ON_MIN}			300		ns
EN Rising threshold voltage	V _{EN_H}	V _{EN} rising	1.5			V
EN Falling threshold	V _{EN_L}	V _{EN} falling			0.4	V
EN Input current	I _{IN}	V _{EN} = 0V to V _{IN}			1	uA
Soft-Start Time	t _{SS}			1		ms
Thermal Shutdown Temperature	T _{SD}			160		°C
Thermal Shutdown Hysteresis	T _{HYS}			15		°C

Notes: 1.A stands for internal 1,4 DC/DC Converter
 2.B stands for internal 2,3 DC/DC Converter

FUNCTIONAL DESCRIPTION

The BCT1901 is a high performance, Quad-Output , 2x1.2A, 2x2A Synchronous step-down converter. The Output Voltage can be programmed with external feedback to any voltage, ranging from 0.6V to the input voltage.

At dropout operation, the converter duty cycle increases to 100% and the output voltage tracks the input voltage minus the RDS(ON) drop of the high-side MOSFET.

The internal error amplifier and compensation provides excellent transient response, load, and line regulation. Soft start function prevents input inrush current and output overshoot during start up.

APPLICATION INFORMATION

Setting the Output Voltage

The internal reference VREF is 0.6V (Typical).The output voltage is divided by a resistor, R1 and R2 to the FB pin. The output voltage is given by:

$$V_{OUT} = 0.6 \times \left(1 + \frac{R1}{R2}\right)$$

Inductor Selection

For most designs, the BCT1900 operates with inductors of 1μH to 4.7μH. Low inductance values are physically smaller but require faster switching, which results in some efficiency loss. The inductor value can be derived from the following equation:

$$L = \left(V_{OUT} \times \frac{V_{IN} - V_{OUT}}{V_{IN} \times \Delta I_L \times f_S}\right)$$

Where ΔIL is inductor Ripple Current. Large value inductors result in lower ripple current and small value inductors result in high ripple current. For optimum voltage-positioning load transients, choose an inductor with DC series resistance in the 50mΩ to 150mΩ range.

Input Capacitor Selection

The input capacitor reduces the surge current drawn from the input and switching noise from the device. The input capacitor impedance at the switching frequency should be less than input source impedance to prevent high frequency switching current passing to the input. A low ESR input capacitor sized for maximum RMS current must be used. Ceramic capacitors with X5R or X7R dielectrics are highly recommended because of their low ESR and small temperature coefficients. A 4.7μF ceramic capacitor for most applications is sufficient. A large value may be used for improved input voltage filtering.

Output Capacitor Selection

The output capacitor is required to keep the output voltage ripple small and to ensure regulation loop stability. The output capacitor must have low impedance at the switching frequency. Ceramic capacitors with X5R or X7R dielectrics are recommended due to their low ESR and high ripple current ratings. The output voltage ripple can be estimated:

$$\Delta V_{OUT} = \frac{V_{OUT}}{f_s \times L} \times \left(1 - \frac{V_{OUT}}{V_{IN}}\right) \times \left(R_{ESR} + \frac{1}{8 \times f_s \times C_2}\right)$$

PCB Layout Recommendations

When laying out the printed circuit board, the following checking should be used to ensure proper operation of the BCT1901 Check the following in your layout:



BCT1901

Quad-Output, 2x1.2A, 2x2A

Synchronous Step-Down Converter

The power traces, consisting of the GND trace, the SW trace and the VIN trace should be kept short, direct and wide

Does the (+) plates of CIN connect to VIN as closely as possible. This capacitor provides the AC current to the internal power MOSFETs.

Keep the switching node, SW, away from the sensitive VOUT node.

Keep the (-) plates of CIN and COUT as close as possible

PACKAGE OUTLINE DIMENSIONS

QFN4x4-24L

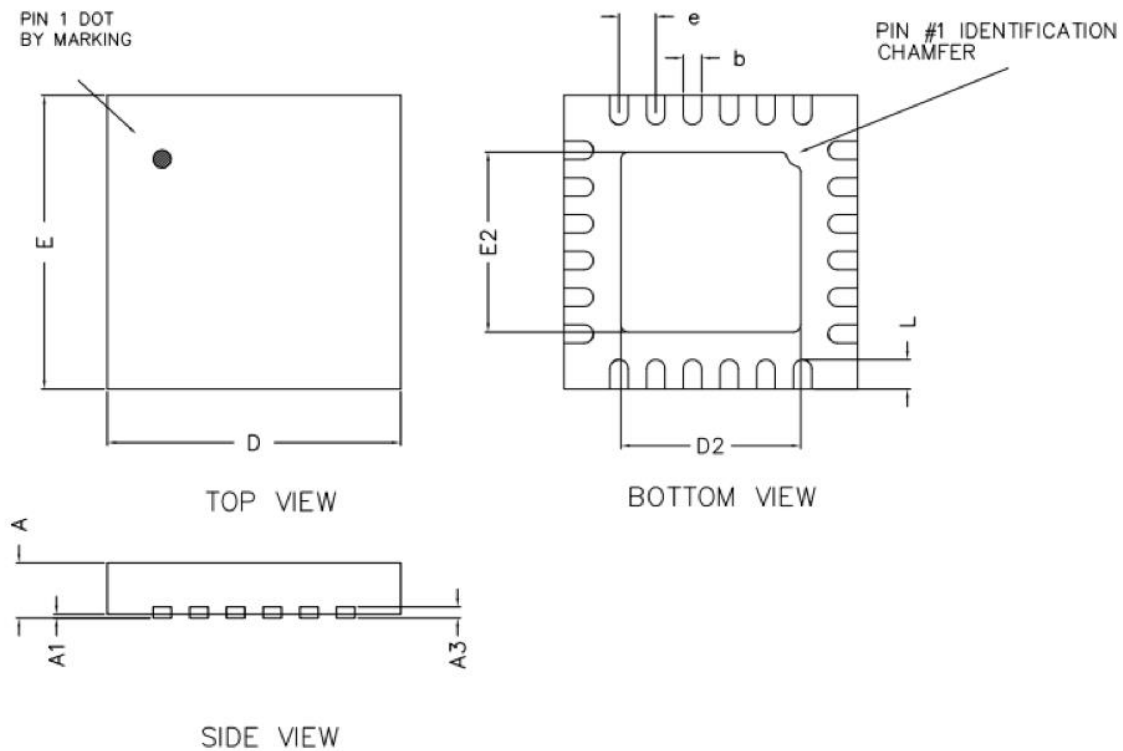

Symbol	Dimensions In Millimeters (Unit: mm)		
	Min	Mean	Max
A	0.70	0.75	0.80
A1	0.00	-	0.05
A3	0.2 REF		
D	3.95	4.00	4.05
E	3.95	4.00	4.05
b	0.18	0.23	0.28
L	0.30	0.40	0.50
D2	2.30	2.45	2.55
E2	2.30	2.45	2.55
e	0.50 BSC		

QFN4x4-24L Surface Mount Package