

CORE DIMENSIONS:

A	12.00 [.472]	+	0.33 [.013]
B	7.00 [.276]	+	0.13 [.005]
C	15.00 [.591]	+	0.25 [.010]
D	5.54 [.218]	+	0.20 [.008]
E	4.62 [.182]	+	0.30 [.012]

Weight/1000 5.11 kgs 11.26 lbs.
(Per Pair)

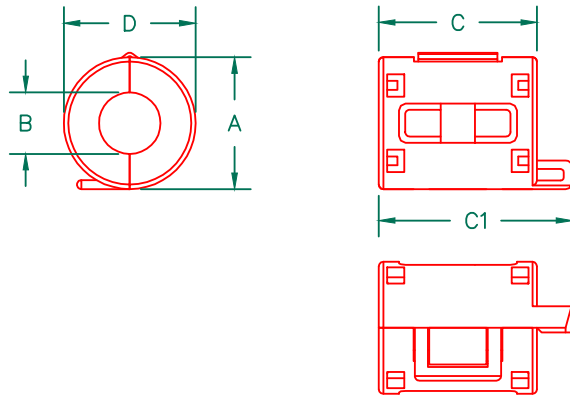

CASE DIMENSIONS:

A	15.00 [.591]	+	0.30 [.012]
B	7.00 [.276]	+	0.20 [.008]
C	18.00 [.709]	+	0.30 [.012]
C1	22.00 [.866]	+	0.38 [.015]
D	15.00 [.591]	+	0.38 [.015]

RoHS

IMPEDANCE (Z)			
Frequency	25 MHz	100 MHz	300 MHz
Nominal (REF)	56 Ω	123 Ω	246 Ω
Minimum	- Ω	98 Ω	- Ω

Z vs. FREQUENCY
(REF. ONLY)

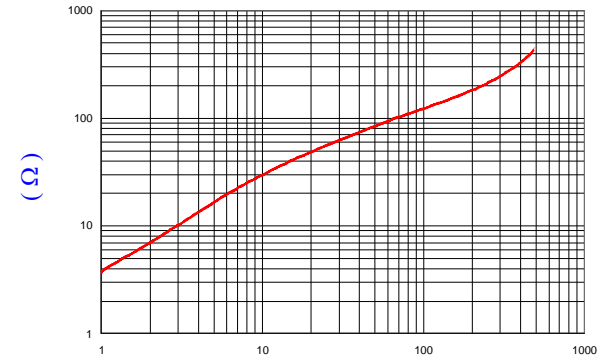

FREQUENCY (MHz)

AGILENT E4991A Impedance/Material Analyzer HP 16194A

Properties		Value	Unit	Tol.
Material		Ferrite		
Initial Permeability	μ_i	850		typ.
Curie Temperature	T_C	150	°C	typ.
Plastic Housing Color		Black\Grey		
Plastic Housing Flammability Rating		UL94V-0		
Test Cable		AWG26		
Test Cable Length		100	mm	
Cable Diameter		7	mm	



深圳市韩下电子有限公司

HX 1518-0730-BK-70A



Drawn: 黄彬

Check: 张伟

Approved: 罗小春



深圳市韩下电子有限公司

Shenzhen Hanxia Electronic Co., Ltd
Tel: 0755-33819206 Fax: 0755-27597491

承 认 书

SPECIFICATION FOR APPROVAL

客 户 Customer:

产品名称 Project:

磁环

规格型号 Part No:

HX 1518-0730-BK-70A

贵公司承认印 Approval signatures

料 号/Part No.	签 章/Signatures

日期 Date:

拟制/Drawn	黄彬	
审核/Check	张伟	
批准/Approved	罗小春	