

DF63 Series

15A 3.96mm pitch Wire-to-Board Connectors for Internal Power Supply (UL, C-UL and TÜV Listed)



Power Supply



Positive-Lock



Compact

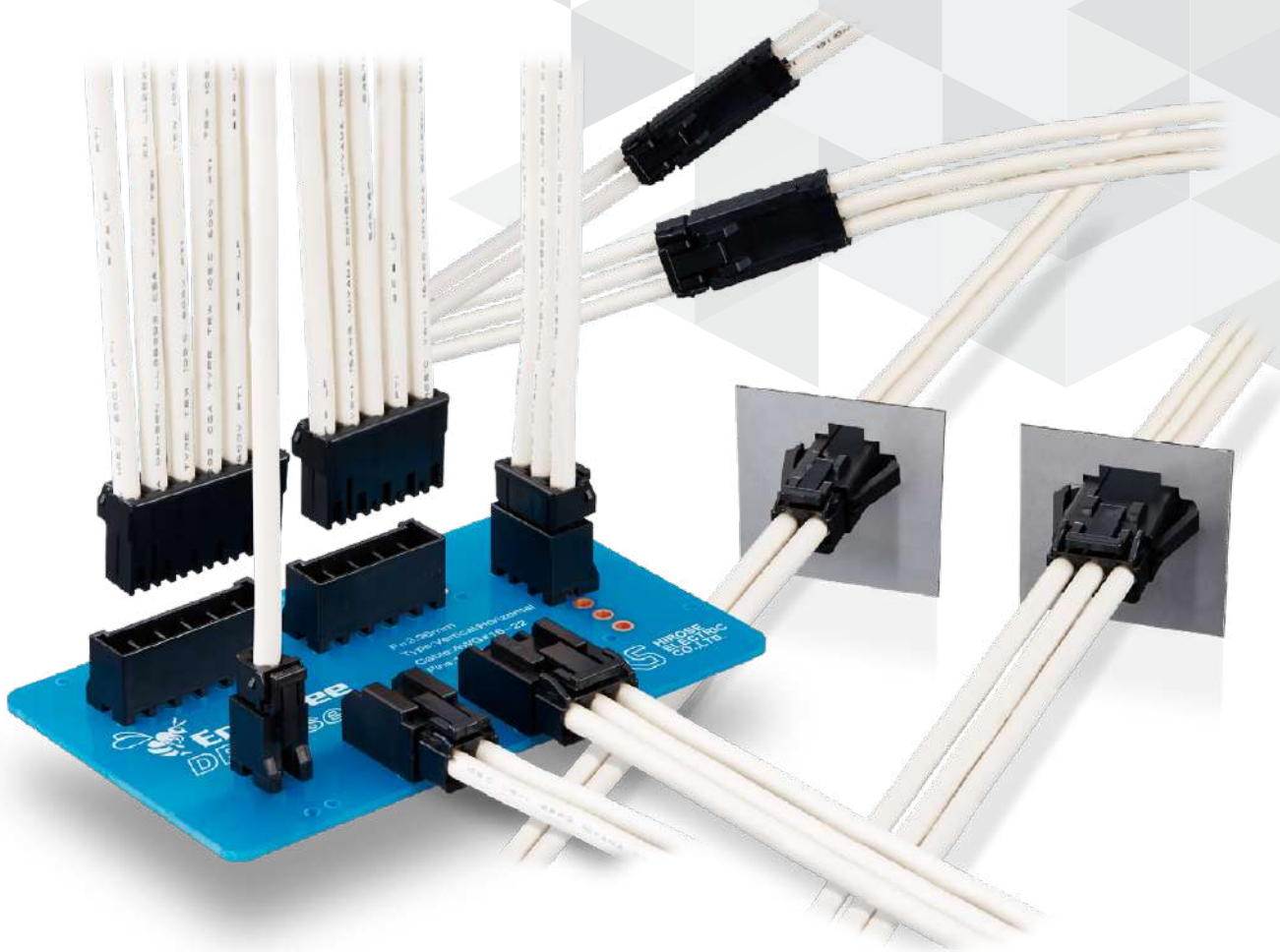

Jun.1.2024 Copyright 2024 HIROSE ELECTRIC CO., LTD. All Rights Reserved.



Product page
<https://www.hirose.com/product/en/products/DF63/>



Special features page
<https://www.hirose.com/product/en/pr/enerbee/>

Feb. 2024

Features

1. Rated for up to 15A

DF63 has the capacity to handle a Max. of 15A when using 16 AWG wire. (Please refer to the chart for the rated current in other pin counts.)

* Supports 7.92mm pitch
 Also supports 7.92mm pitch with 2 or 3 pos. without pins.
 The product will be available upon request.
 Please contact Hirose representative.

2. Secure mating and clear tactile click

The locking mechanism delivers a clear and tactile click, which prevents incomplete mating and reduces burden on workers for improved work efficiency.

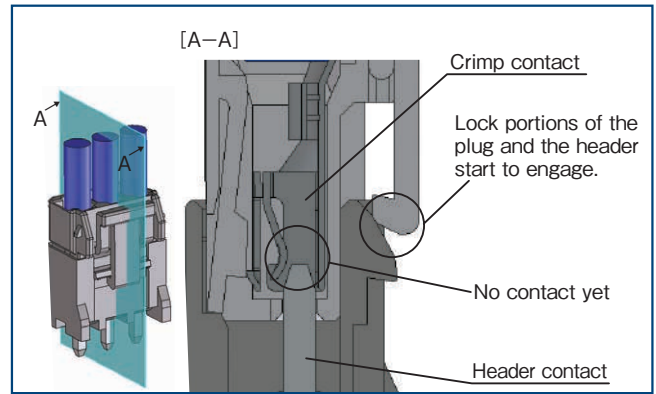

Lock structure

3. Prevents incomplete insertion of the crimp contact

A structure to prevent incomplete insertion of the crimp contacts is provided.

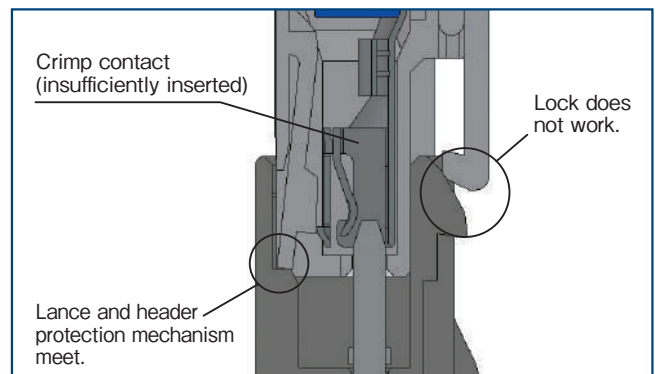

Prevention of insufficient insertion of the crimp contact

4. Reverse mounting prevention to PCB

The pin header is equipped with a guide post to prevent reverse insertion on the PCB.

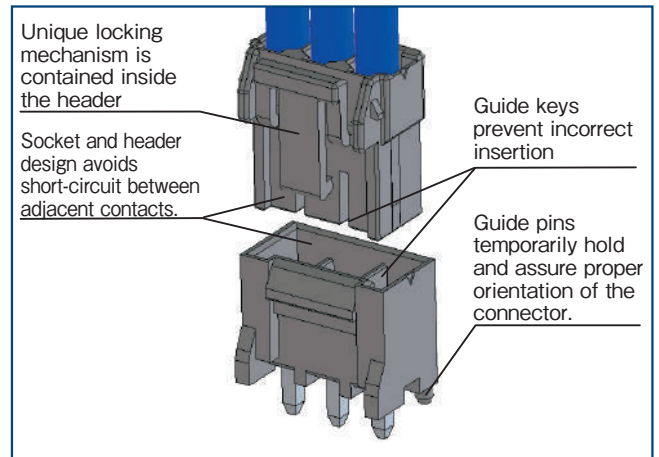

5. Short-circuit prevention

The wall structure between the contacts helps to isolate the contacts and prevents short circuits between contacts.

6. Molded lance design

The lance is actually part of the housing instead of being a part of the terminal. This prevents tangled wires during assembly.

7. Suitable for potting

Capable of being potted, up to 5mm.

8. Solder crack prevention

Glass-reinforced resin is used on the pin header to prevent solder cracks due to thermal contraction.

Product Specifications

Rated Current	No of Pos.	16 AWG	18 AWG	20 AWG	22 AWG	Operating Temperature (Note 2)	-55 to +105°C
	1	15A	13A	11A	9A	Storage Temperature Range (Note 3)	-10 to +60°C
	2	14A	12A	10A	8A	Operating Humidity Range (Note 4)	20 to 80%
	3	12A	10A	8A	7A	Storage Humidity Range (Note 3)	40 to 70%
	4	10A	8A	7A	6A		
	5	10A	8A	7A	6A		
	6	10A	8A	7A	6A		
	2 (7.92mm Pitch)	15A	13A	11A	9A		
	3 (7.92mm Pitch)	12A	11A	9A	8A		
Rated Voltage	630V AC/DC						

Voltage Rating	UL	600V AC/DC
	C-UL	600V AC/DC
	TÜV	300V AC/DC

UL/TÜV File No. and Recognition No.
 UL : E52653
 C-UL : E52653
 TÜV : R50318850

Item	Specifications	Conditions
Insulation Resistance	No less than 1,000M Ω	Measured at 500V DC
Withstand Voltage	No flashover or breakdown	1,500V AC is applied for 1 min.
Contact Resistance	No more than 10m Ω	Measured at 1mA and no higher than 20mV
Vibration Resistance	No electrical discontinuity of 1 μ s or greater	Frequency 10 to 55 Hz, half amplitude 0.75 mm, 10 times in each of the 3 directions
Shock Resistance	No electrical discontinuity of 1 μ s or greater	Accelerated velocity : 490 m/s ² for 11ms, half-sine wave in 3 directions, 3 times for each direction
Moisture-resistance	Contact resistance : no more than 20m Ω Insulation resistance : no less than 500M Ω	Temperature : 40 \pm 2°C ; humidity : 90 to 95%, left as it is for 96 hours
Temperature Cycles	Contact resistance : no more than 20m Ω Insulation resistance : no less than 1,000M Ω	-55°C : 30 minutes \rightarrow +85°C : 30 minutes 5 cycles
Mating Durability	Contact resistance : no more than 20m Ω	Tin Plated : 30 mating cycles Gold Plated : 50 mating cycles
Solder Heat Resistance	The resin parts should withstand the temperature and resist melting.	Straight Header Flow : 260°C , 5 sec Hand soldering : temperature of soldering iron at 290°C for 3 seconds Right Angle Header Flow : 260°C , 10 sec Hand soldering : temperature of soldering iron at 300°C for 3 seconds

Note 1 : This is the maximum current rating while all pins are powered or used as all power lines.

Note 2 : Includes temperature rise caused by current flow.

Note 3 : Applicable to unused product packaging.

Note 4 : Use without condensation on parts.

Note 5 : Information contained in this catalog represents general requirements for this Series. Contact us for the drawings and specifications for a specific part number shown.

Materials / Finish

Component	Part	Material	Finish	UL Specification
Header	Insulator	PBT (glass-reinforced)	Black or White	UL94V-0
	Contact	Brass	Tin plated or Gold plated	-
Crimp socket	Insulator	PBT (glass-reinforced)	Black or White	UL94V-0
In-line plug				
Crimp contact	Contact	Copper alloy	Tin plated or Gold plated	-

Product Number Structure

Refer to the chart below when determining the product specifications from the product number. Please select from the product numbers listed in this catalog when placing orders.

Connector

DF63 # - # P - 3.96 DSA

① ② ③ ④ ⑤ ⑥

Crimp contact

DF63 # - 1618 SCF

① ② ⑦ ⑧

① Series name	DF63	⑤ Contact Pitch	3.96mm 7.92mm
② Form Type	Header Blank or M : Black Sockets Blank : Black In-line Plugs Blank : Panel Lock Type A : Without Panel Lock Socket contacts A : Standard In-Line plug contacts Blank : Standard	⑥ Type of housing	DSA : Straight header DS : Right angle header C : Crimp housing
③ No. of Pos.	1,2,3,4,5,6	⑦ Applicable Conductor	1618 : 16-18 AWG 2022 : 20-22 AWG
④ Connector type	P : Pin Header S : Crimp socket EP : In-line plug	⑧ Packaging	SCF : Socket contacts/Reel/Tin plated SCFA : Socket contacts/Reel/Gold plated SC : Socket contacts/Pack/Tin plated SCA : Socket contacts/Pack/Gold plated PCF : In-line plug contacts/Reel/Tin plated PCFA : In-line plug contacts/Reel/Gold plated PC : In-line plug contacts/Pack/Tin plated PCA : In-line plug contacts/Pack/Gold plated

Straight Header



[1 pos.]

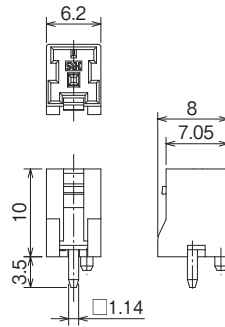

[2 to 6 pos.]

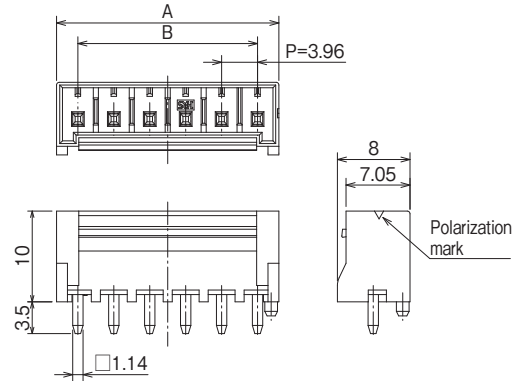

*Diagram of standard type.

● Recommended PCB Layout (Board thickness : 1.6±0.1)

[1 to 6 pos.]

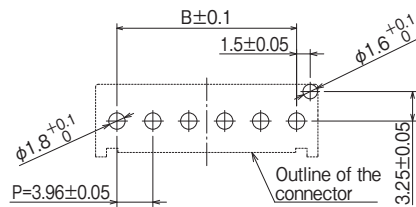

Standard Type (Guide post : Left Side, Color : Black)

Unit : mm

Part No.	HRS No.	No. of Pos.	A	B	Purchase Unit
DF63M-1P-3.96DSA(##)	CL0680-0566-0-##	1	6.20	-	100pcs per bag
DF63M-2P-3.96DSA(##)	CL0680-0567-0-##	2	8.66	3.96	
DF63M-3P-3.96DSA(##)	CL0680-0568-0-##	3	12.62	7.92	
DF63M-4P-3.96DSA(##)	CL0680-0569-0-##	4	16.58	11.88	
DF63-5P-3.96DSA(##)	CL0680-0506-7-##	5	20.54	15.84	
DF63-6P-3.96DSA(##)	CL0680-0507-0-##	6	24.50	19.80	

7.92mm pitch

Unit : mm

Part No.	HRS No.	No. of Pos.	A	B	Purchase Unit
DF63M-2P-7.92DSA(##)	CL0680-0581-0-##	2	12.62	7.92	100pcs per bag
DF63-3P-7.92DSA(##)	CL0680-0537-0-##	3	20.54	15.84	

[Specification number(##), -##] None : Tin plated, (01) : Gold plated
 Note : Please contact Hirose representative if you have request for (01) specification.

Right Angle Header

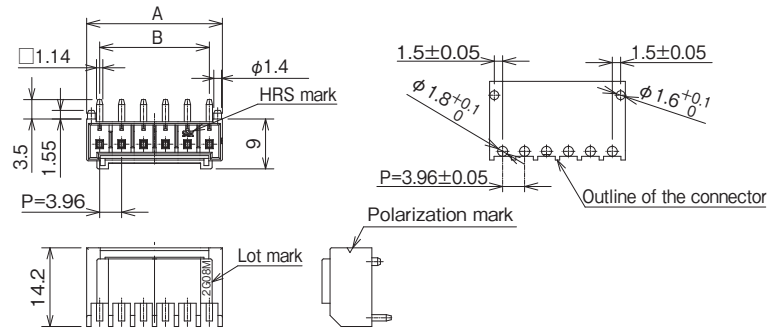

Standard Type (Color : Black)

Unit : mm

Part No.	HRS No.	No. of Pos.	A	B	Purchase Unit
DF63M-1P-3.96DS(##)	CL0680-0570-0-##	1	6.20	-	100pcs per bag
DF63M-2P-3.96DS(##)	CL0680-0571-0-##	2	8.66	3.96	
DF63M-3P-3.96DS(##)	CL0680-0572-0-##	3	12.62	7.92	
DF63-4P-3.96DS(##)	CL0680-0545-0-##	4	16.58	11.88	
DF63-5P-3.96DS(##)	CL0680-0546-0-##	5	20.54	15.84	
DF63-6P-3.96DS(##)	CL0680-0547-0-##	6	24.50	19.80	

7.92mm pitch

Unit : mm

Part No.	HRS No.	No. of Pos.	A	B	Purchase Unit
DF63M-2P-7.92DS(##)	CL0680-0583-0-##	2	12.62	7.92	100pcs per bag
DF63-3P-7.92DS(##)	CL0680-0559-0-##	3	20.54	15.84	

[Specification number(##), -##] None : Tin plated, (01) : Gold plated
 Note : Please contact Hirose representative if you have request for (01) specification.

Crimp Socket

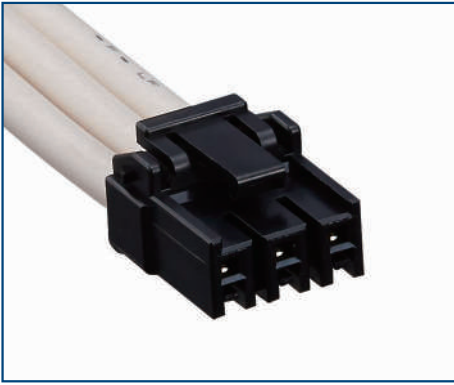

Shown with terminated and contacts installed.

[1 pos.]

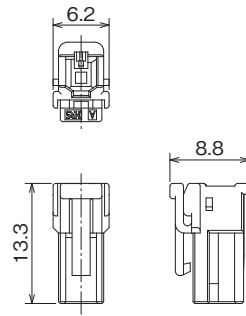

[2 to 6 pos.]

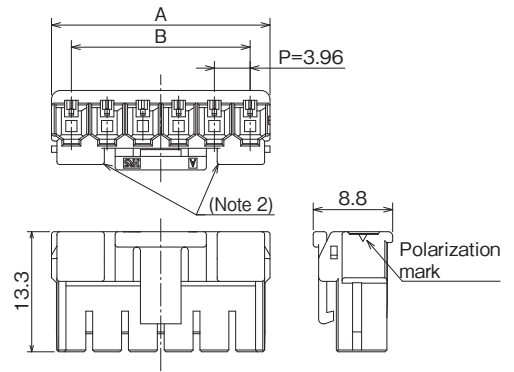

Standard Type

Unit : mm

Part No.	HRS No.	No. of Pos.	A	B	Purchase Unit
DF63-1S-3.96C(##)	CL0680-0508-2-##	1	6.20	-	100pcs per bag
DF63-2S-3.96C(##)	CL0680-0509-5-##	2	8.36	3.96	
DF63-3S-3.96C(##)	CL0680-0502-6-##	3	12.32	7.92	
DF63-4S-3.96C(##)	CL0680-0510-4-##	4	16.28	11.88	
DF63-5S-3.96C(##)	CL0680-0511-7-##	5	20.24	15.84	
DF63-6S-3.96C(##)	CL0680-0512-0-##	6	24.20	19.80	

[Specification number(##), -##] None : Black

In-line Plug (Panel Lock Type)



Shown with terminated and contacts installed.

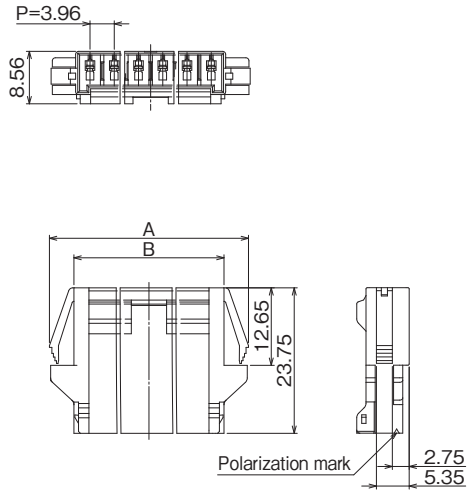

■ Recommended Panel Cutout

[1 pos.]

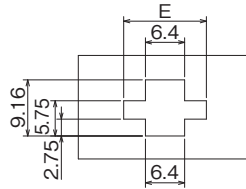

[2 to 6 pos.]

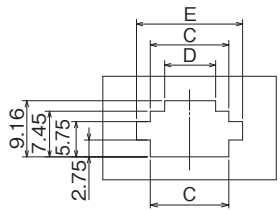

Unit : mm

Part No.	HRS No.	No. of Pos.	A	B	C	D	Purchase Unit
DF63-1EP-3.96C(##)	CL0680-0551-0-##	1	14.20	6.20	-	-	100pcs per bag
DF63-2EP-3.96C(##)	CL0680-0533-0-##	2	16.66	8.66	8.86	4.96	
DF63-3EP-3.96C(##)	CL0680-0532-7-##	3	20.62	12.62	12.82	8.32	
DF63-4EP-3.96C(##)	CL0680-0552-0-##	4	24.58	16.58	16.78	12.28	
DF63-5EP-3.96C(##)	CL0680-0553-0-##	5	28.54	20.54	20.74	16.24	
DF63-6EP-3.96C(##)	CL0680-0554-0-##	6	32.50	24.50	24.70	20.20	

Unit : mm

E	Panel thickness	No. of Pos.					
		1	2	3	4	5	6
	0.5 to 0.6	10.30	12.76	16.72	20.68	24.64	28.60
	0.7 to 1.1	10.80	13.26	17.22	21.18	25.14	29.10
	1.2 to 1.7	11.30	13.76	17.72	21.68	25.64	29.60
	2.0 to 2.3	11.80	14.26	18.22	22.18	26.14	30.10

[Specification number(##), -##] None : Black

In-line Plug



Shown with terminated and contacts installed.

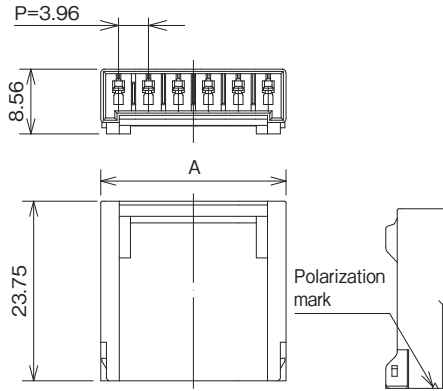

Unit : mm

Part No.	HRS No.	No. of Pos.	A	Purchase Unit
DF63A-1EP-3.96C(##)	CL0680-0555-0-##	1	6.20	100pcs per bag
DF63A-2EP-3.96C(##)	CL0680-0535-5-##	2	8.66	
DF63A-3EP-3.96C(##)	CL0680-0534-2-##	3	12.62	
DF63A-4EP-3.96C(##)	CL0680-0556-0-##	4	16.58	
DF63A-5EP-3.96C(##)	CL0680-0557-0-##	5	20.54	
DF63A-6EP-3.96C(##)	CL0680-0558-0-##	6	24.50	

[Specification number(##), -##] None : Black

Crimp Contact for Socket

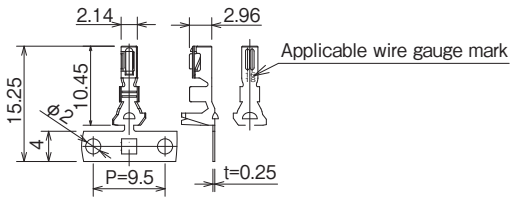

Reel Contact (4,000pcs per reel) *Applicable tool : Applicator

Part No.	HRS No.	Finish	Applicable Wire (Tin Plated Annealed Copper) (Note 1)					RoHS
			UL	Wire Size	Stranded Wire Structure	Calculated Cross-section	Jacket Diameter	
DF63A-1618SCF	CL0680-0573-0-00	Tin Plated	1007	16 AWG	26/0.254mm	1.317m ²	φ 2.1 to 3.2mm	Yes
			1015	18 AWG	34/0.18mm	0.865m ²		
DF63A-1618SCFA	CL0680-0646-0-00	Gold Plated	1007	16 AWG	26/0.254mm	1.317m ²	φ 2.1 to 3.2mm	
			1015	18 AWG	34/0.18mm	0.865m ²		
DF63A-2022SCF	CL0680-0097-0-00	Tin Plated	1007	20 AWG	21/0.18mm	0.534m ²	φ 1.7 to 1.8mm	
				22 AWG	17/0.16mm	0.342m ²		
DF63A-2022SCFA	CL0680-0647-0-00	Gold Plated	1007	20 AWG	21/0.18mm	0.534m ²	φ 1.7 to 1.8mm	
				22 AWG	17/0.16mm	0.342m ²		

Note 1 : When using a wire other than the applicable wires please contact a Hirose representative.

Loose piece (100pcs per bag) *Applicable tool : Hand crimping tool

Part No.	HRS No.	Finish	Applicable Wire (Tin Plated Annealed Copper) (Note 1)					RoHS
			UL	Wire Size	Stranded Wire Structure	Calculated Cross-section	Jacket Diameter	
DF63A-1618SC	CL0680-0648-0-00	Tin Plated	1007	16 AWG	26/0.254mm	1.317m ²	2.5mm	Yes
				18 AWG	34/0.18mm	0.865m ²	2.1mm	
			1015	16 AWG	26/0.254mm	1.317m ²	3.2mm	
				18 AWG	34/0.18mm	0.865m ²	2.9mm	
DF63A-1618SCA	CL0680-0650-0-00	Gold Plated	1007	16 AWG	26/0.254mm	1.317m ²	2.5mm	
				18 AWG	34/0.18mm	0.865m ²	2.1mm	
			1015	16 AWG	26/0.254mm	1.317m ²	3.2mm	
				18 AWG	34/0.18mm	0.865m ²	2.9mm	
DF63A-2022SC	CL0680-0649-0-00	Tin Plated	1007	20 AWG	21/0.18mm	0.534m ²	1.8mm	
				22 AWG	17/0.16mm	0.342m ²	1.7mm	
DF63A-2022SCA	CL0680-0651-0-00	Gold Plated	1007	20 AWG	21/0.18mm	0.534m ²	1.8mm	
				22 AWG	17/0.16mm	0.342m ²	1.7mm	

Note 1 : When crimping using a hand crimping tool only the above wires are applicable.

● Crimp Contact extraction tool

DF-C-PO(B), Flat-bladed screwdriver, 1.2mm blade width

● Strip length

2.9 to 3.6mm

Crimp Contact for In-line Plug

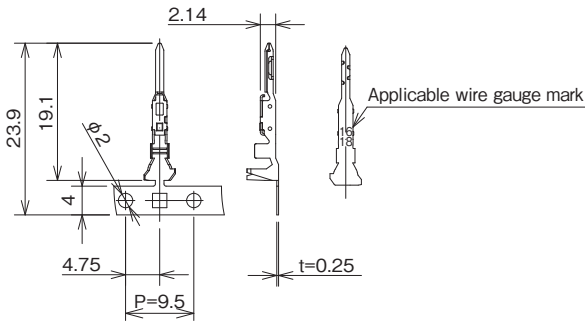

Reel Contact (4,000pcs per reel) *Applicable tool : Applicator

Part No.	HRS No.	Finish	Applicable Wire (Tin Plated Annealed Copper) (Note 1)					RoHS
			UL	Wire Size	Stranded Wire Structure	Calculated Cross-section	Jacket Diameter	
DF63-1618PCF	CL0680-0529-2-00	Tin Plated	1007	16 AWG	26/0.254mm	1.317m ²	φ 2.1 to 3.2mm	Yes
			1015	18 AWG	34/0.18mm	0.865m ²		
DF63-1618PCFA	CL0680-0636-0-00	Gold Plated	1007	16 AWG	26/0.254mm	1.317m ²	φ 2.1 to 3.2mm	
			1015	18 AWG	34/0.18mm	0.865m ²		
DF63-2022PCF	CL0680-0538-3-00	Tin Plated	1007	20 AWG	21/0.18mm	0.534m ²	φ 1.7 to 1.8mm	
				22 AWG	17/0.16mm	0.342m ²		
DF63-2022PCFA	CL0680-0638-0-00	Gold Plated	1007	20 AWG	21/0.18mm	0.534m ²	φ 1.7 to 1.8mm	
				22 AWG	17/0.16mm	0.342m ²		

Note 1 : When using a wire other than the applicable wires please contact a Hirose representative.

Loose piece (100pcs per bag) *Applicable tool : Hand crimping tool

Part No.	HRS No.	Finish	Applicable Wire (Tin Plated Annealed Copper) (Note 1)					RoHS
			UL	Wire Size	Stranded Wire Structure	Calculated Cross-section	Jacket Diameter	
DF63-1618PC	CL0680-0536-8-00	Tin Plated	1007	16 AWG	26/0.254mm	1.317m ²	2.5mm	Yes
				18 AWG	34/0.18mm	0.865m ²	2.1mm	
			1015	16 AWG	26/0.254mm	1.317m ²	3.2mm	
				18 AWG	34/0.18mm	0.865m ²	2.9mm	
DF63-1618PCA	CL0680-0637-0-00	Gold Plated	1007	16 AWG	26/0.254mm	1.317m ²	2.5mm	
				18 AWG	34/0.18mm	0.865m ²	2.1mm	
			1015	16 AWG	26/0.254mm	1.317m ²	3.2mm	
				18 AWG	34/0.18mm	0.865m ²	2.9mm	
DF63-2022PC	CL0680-0539-6-00	Tin Plated	1007	20 AWG	21/0.18mm	0.534m ²	1.8mm	
				22 AWG	17/0.16mm	0.342m ²	1.7mm	
DF63-2022PCA	CL0680-0639-0-00	Gold Plated	1007	20 AWG	21/0.18mm	0.534m ²	1.8mm	
				22 AWG	17/0.16mm	0.342m ²	1.7mm	

Note 1 : When crimping using a hand crimping tool only the above wires are applicable.

● Crimp Contact extraction tool

DF-C-PO(B), Flat-bladed screwdriver, 1.2mm blade width

● Strip length

2.9 to 3.6mm

Mated Dimensions

- Board-to-Wire Connection using the straight pin header

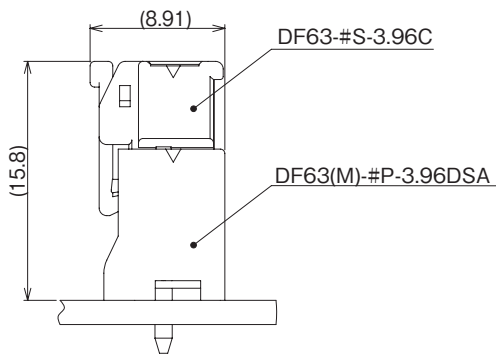

- Socket to Right Angle Header Connection

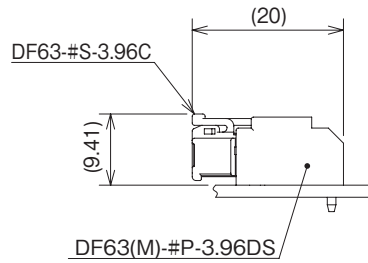

- Socket to In-line Plug Connection

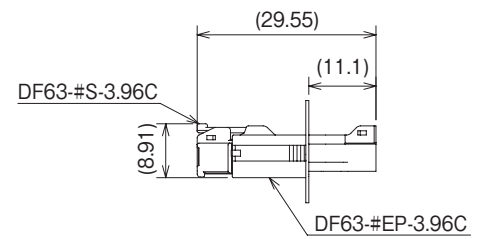

Applicable Crimping Tool

Type	Part No.	HRS No.	Wire Type	Applicable Contacts	
Applicator	AP105-DF63-1618S-1	CL0901-4634-1-00	UL1007 (Note 3)	DF63A-1618SCF DF63A-1618SCFA	
	AP105-DF63-1618S-2	CL0901-4635-4-00	UL1015 (Note 3)		
	CHS893400H-UP (Note 8)	—	UL1015		
	Applicator	AP105-DF63-1618-3	CL0901-4642-0-00	UL1007 (Note 3)	DF63-1618PCF DF63-1618PCFA DF63W-1618SCF
		AP105-DF63-1618-4	CL0901-4643-2-00	UL1015 (Note 3)	
		CHS893500H-UP (Note 8)	—	UL1015	
		AP105-DF63-2022-1	CL0901-4617-0-00	UL1007	DF63A-2022SCF DF63A-2022SCFA
		AP105-DF63-2022-3	CL0901-4646-0-00	UL1007	DF63-2022PCF DF63-2022PCFA DF63W-2022SCF
Hand tool	HT802/DF63-1618S-1	CL0550-0411-2-00	UL1007 (Note 4, 5)	DF63A-1618SC DF63A-1618SCA	
	HT802/DF63-1618S-2	CL0550-0413-8-00	UL1015 (Note 4, 6)		
	HT802/DF63-1618P-1	CL0550-0423-1-00	UL1007 (Note 4, 5)	DF63-1618PC DF63-1618PCA	
	HT802/DF63-1618P-2	CL0550-0424-4-00	UL1015 (Note 4, 6)		
	HT802/DF63-2022S-1	CL0550-0432-0-00	UL1007 (Note 4, 7)	DF63A-2022SC DF63A-2022SCA	
	HT802/DF63-2022P-1	CL0550-0433-0-00		DF63-2022PC DF63-2022PCA	

Note 1 : Please conduct crimping work according to the "Crimping quality control statement of standards (ETAD-H0730-00, ETAD-H0810-00)" and "Crimping condition table".

Note 2 : Any problems that occur from using tools other than those specified by Hirose, are not covered by warranty.

Note 3 : Applicator dies can be switched to crimp the other wire size and type. The additional dies are sold separately.

Note 4 : Hand tool dies cannot be switched.

Note 5 : The compatible wire is limited to UL1007, 16 to 18 AWG

Note 6 : The compatible wire is limited to UL1015, 16 to 18 AWG

Note 7 : The compatible wire is limited to UL1007, 20 to 22 AWG

Note 8 : Applicator manufactured by JAPAN AUTOMATIC MACHINE (J.A.M.). Please access to HP of J.A.M., if you make inquiries about the applicator or crimp defect. (URL : <http://www.jam-net.co.jp>)

Contact Extraction

Contact extraction tool : Flat-bladed screwdriver. 1.2mm blade width or DF-C-PO(B)

Intended crimp Contacts : DF63A-1618SC(F)(A), DF63A-2022SC(F)(A), DF63-1618PC(F)(A), DF63-2022PC(F)(A)

● Work Method

1. Refer to the drawing No.1. Insert correct size contact extraction tool in the insulator against the molded-in lance. Deflect the lance as shown.
2. Assure that the lance is deflected to release the contact and pull-out wire with the terminated contact.

Housing Cross Sectional Diagram

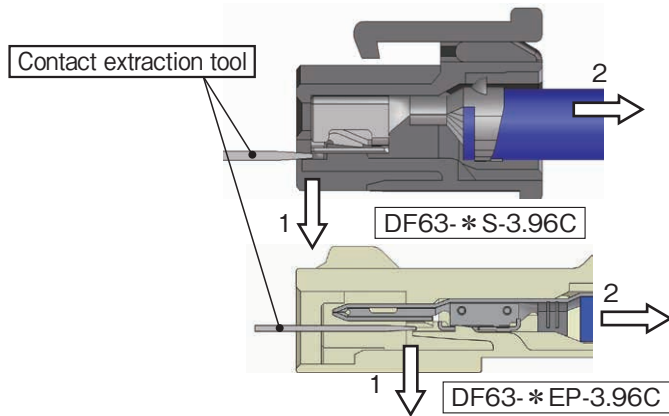

* Using crimping socket after repair could induce decrease of lance strength, use new socket to avoid such failures.

⚠ Caution There are parts on the crimp contact that can cause injuries, please use caution when unmating the contacts.

Precautions for use

1. The connector could be damaged if it is pulled out forcibly. When it is hard to pull out, push it in slightly first and then depress the lock and un-mate.
2. When thick, short sections of wire are used, the connector could be deformed due to the force of the wires' position. Route cables in such a way that they do not twist when being installed.
3. Make sure to turn off the power when mating or un-mating the connector.
4. Please do not touch any area around the contact part with your hand when the power is on; it could be very dangerous.
5. Please refer to the materials listed below when handling this product.
 - Crimping quality control statement of standards (ETAD-H0730-00, ETAD-H0810-00)
 - Harness procedure manual (ETAD-H0737-00)
 - Insertion/extraction manual (ETAD-H0892-00)
 - Board-to-Wire Connector Guidelines (ETAD-H1023-00)
6. The color of the plastic molding may differ slightly depending on product lot and future storage conditions but this does not affect the product performance.
7. Black spots may appear on the mold resin but this does not affect the product quality.

Rated values

- Please avoid using the connectors above the ratings. Also, do not insert or pull out energized or "live" wires.
- "Live wire insertion" refers to insertion while electricity is running.

Operating environment

- Please contact us if you are designing this connector into environmental conditions where high and low temperatures are repeated.

While Taking into Consideration

Specifications mentioned in this catalog are reference values.

When considering to order or use this product, please review the Drawing and Product Specifications sheets.

Use an appropriate cable when using the connector in combination with cables.

If considering usage of a non-specified cable, please contact your sales representative.

If assembly process is done by jigs & tools which are not identified by Hirose, the warranty of the product may be affected.

If considering usage for below mentioned applications, please contact your sales representative.

In cases where the application will demand a high level of reliability, such as automotive, medical instruments, public infrastructure, aerospace/defense etc. Hirose must review before assurance of reliability can be given.