

STANDARD SPECIFICATION

产品规格书

客户 Customer : _____

客户料号 Customer P/N NO. : _____

产品描述 Product Description : 2520-4P 26.000MHZ 7PF ±10PPM

HX 料号 P/N. NO. : 2TS026000RP

客户批准 Customer Approval :

审 核	批 准
Checked	APPROVED

(请批准后回签一份 PLEASE RETURN A COPY WITH APPROVAL)

拟 制 DESIGNER	审 核 CHECK	批 准 APPROVED
万力阳	蔡勤	柯建平

地址：深圳市龙华区龙胜路融创智汇大厦C座1401-1402室

Office add: Room 1401-1402, Building C, Rongchuang, Longhua District, shenzhen

TEL: 0755-21044642



● PRODUCT DESCRIPTION

1. Standard atmospheric conditions

Unless otherwise specified. The standard range of atmospheric conditions for making measurement and tests are as follow:

Ambient temperature : $25 \pm 10^{\circ}\text{C}$

Relative humidity : 40%~70%

If there is any doubt about the results, measurement shall be made within the following limit:

Ambient temperature : $25 \pm 2^{\circ}\text{C}$

Relative humidity : 40%~70%

2. Measure equipment

Electrical characteristics measured by S&A 250B or equivalent.

● ELECTRICAL SPECIFICATIONS

1. Quartz Crystal Unit Specification

NO.	Parameters	Symbol	Specifications				Notes
			Min	Type	Max	Units	
1	Nominal frequency	FL	26.000			MHz	
2	Mode of Oscillation	-	Fundamental				AT-CUT
3	Load Capacitance	CL	7			pF	
4	Frequency Tolerance	FL	± 10			ppm	at $25 \pm 2^{\circ}\text{C}$
5	Frequency Stability	TC	± 12			ppm	at $-30^{\circ}\text{C} \sim +85^{\circ}\text{C}$
6	Operating Temperature	-	-30	~	+105	$^{\circ}\text{C}$	
7	Drive Level	DL	10		100	μW	
8	Effective Resistance	RR			80	Ω	
9	Shunt Capacitance	C0	0.3		1.3	pF	
10	Motional Capacitance	C1	1.8		3.1	fF	
11	Tuning sensitivity	TS	12			ppm/ pF	at CL
12	Spurious mode series resistance	SPUR	1100			Ω	$\pm 1\text{MHz}$
13	Q Factor	Q	75			K	
14	Insulation Resistance	IR	≥ 500			M Ω	at DC 100V
15	Aging	-	± 0.7			ppm	1st year max
16	Reflow		± 2			ppm	Two reflows
17	Inflection Point	Ti	30.5		33.5	$^{\circ}\text{C}$	$T = T_0 - C_2 / (3 * C_3)$
18	Storage Temperature Range	-	-40	~	+105	$^{\circ}\text{C}$	

2. Curve Fitting Parameters

The FT curve of an AT-cut crystal can be modeled as a third-order polynomial.

$$F(T)=C3(T-T0)^3 +C2(T-T0)^2+C1(T-T0)+C0$$

C0 : ±10 ppm

C1 : -0.4 ~ -0.1 ppm/°C

C2 : -4.5 x 10⁻⁴ ~ 4.5 x 10⁻⁴ ppm/°C²

C3 : 8.5 x 10⁻⁵ ~ 11.5 x 10⁻⁵ ppm/°C³

3. Drive level dependency(DLD)

Item		MAX-MIN	Repeatability	Conditions
Drive level dependency	Freq	<3ppm	<0.7ppm	0.01uW to 100uW to 0.01uW
	ESR	<20%	<10%	

Notes:

- 1) Number of points: 15 points up and 15 points down=29 total data points.
- 2) Max-Min: Difference between the maximum and minimum in a two-way measurement.
For ESR, The change rate is (max-min)/min<20%.
- 3) Repeatability: Repeatability of two-way measurement in the above condition. For ESR, The change rate is (ESR2-ESR1)/ESR1<10%.
- 4) ESR1: First measurement on each drive level.
- 5) ESR2: Second measurement on each drive level;

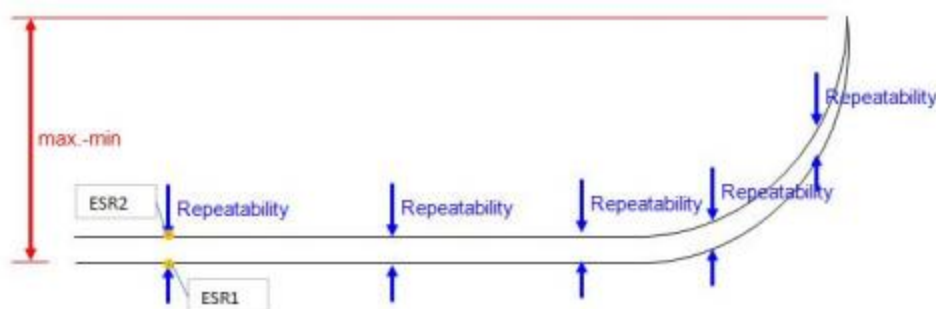

4. Gps Quality Specifications

Crystal perturbation specification 1 (residual frequency stability slope)

Item	Condition	Specification	Unit
Residual frequency stability slope (residual = difference from fifth-order curve fit)*	Ta = -30°C to +85°C	±50 (Max.)	ppb/°C
5 °C small orbit hysteresis 1*	Ta = -30°C to +85°C	±50 (Max.)	ppb/°C

* Must meet the 1A and 1B conditions:

■ Condition 1A -Test condition (continuous temperature rate change of ~1.0 °C/min):

- Measure FT points every 1 °C , heating up from -30 °C to +85 °C , subtract a fifth-order polynomial best fit and then calculate the slope of the residual.
- The residual slope should be within ±50 ppb/°C.

■ Condition 1B-Hysteresis 1 test condition (continuous temperature rate change of ~1.0 °C/min):

Measure FT points every 0.5 °C while cycling temperature over a 5 °C small temperature orbit; an example 5 °C small orbit temperature cycle is +30°C to +35°C to +30°C.

During every individual heating/cooling cycle there should be 11 points; Discard the First point of each heating and cooling cycle; this leaves 10 points for each heating and cooling cycle. Subtract the fifth-order polynomial best fit from 1 A for each of the 10 points, and then calculate the slope of the residual for each of these heating and cooling 10 point curves.

The residual slope should be within ±50 ppb/°C.

Crystal perturbation specification 2 (small orbit hysteresis 2)

Item	Condition	Specification	Unit
5 °C small orbit hysteresis 2*	Ta = -30°C to +85°C	100 (magnitude)	ppb pk-pk

* Must meet condition 2:

■ Condition 2 - Hysteresis 2 test condition (continuous temperature rate change of ~1.0 °C/min):

Measure FT points every 0.5 °C while cycling temperature over a 5 °C small temperature orbit; an example 5 °C small orbit temperature cycle is +30 °C to +35 °C to +30 °C.

During every individual heating/cooling cycle there should be 11 points; Discard the first and last point of each heating and cooling cycle, which results in nine temperature points. Calculate the average measured peak-to-peak frequency difference for these nine temperature points.

The average difference is the magnitude of the small orbit hysteresis 2.

5.Thermistor Specification

	Parameter	Electrical Specification			Units
		Min	Mon	Max	
1	Operating temperature	-30	-	+105	°C
2	Storage temperature	-40	-	+105	°C
3	Resistance(25°C)		100		k Ω
4	B-constant(25~50°C)		4250		K
5	Tolerance			1.0	%

● DIMENSIONS

(unit: mm)

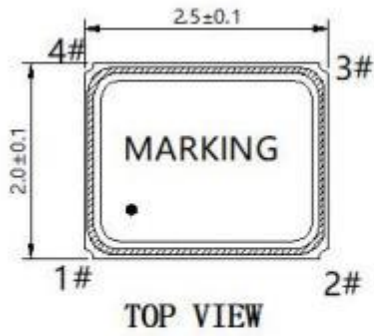

Terminal land connections

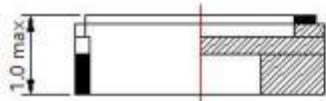
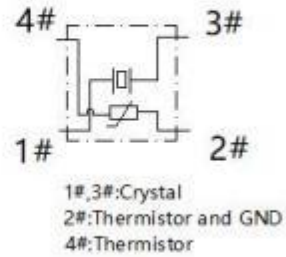

Land pattern (Recommended)

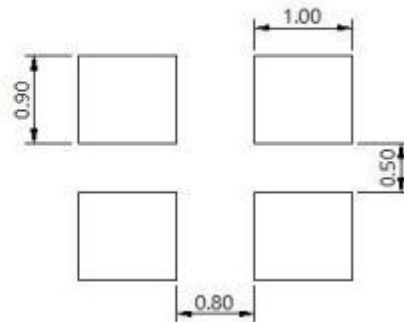
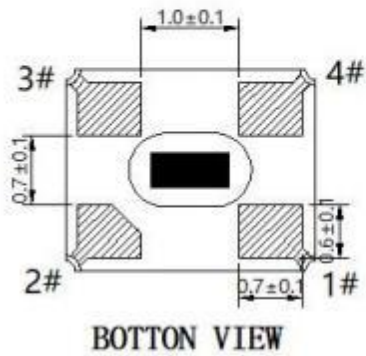

● MARKING

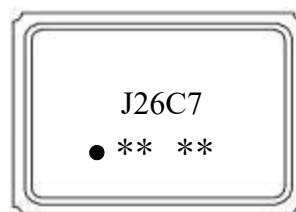

26.000 ----- Frequency(26.0M)

C7 ----- 7PF

** ** ----- 周期

● ----- Pin 1

● SUGGESTED REFLOW PROFILE

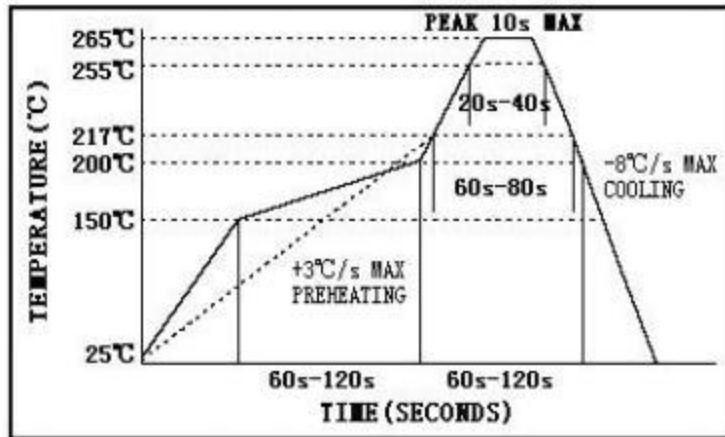

Solder melting point : 217 °C , 60 sec. Min.

Peak Temperature: 260 ± 5 °C , 10 sec. Max. (lead free)

● STRUCTURE ILLUSTRATION

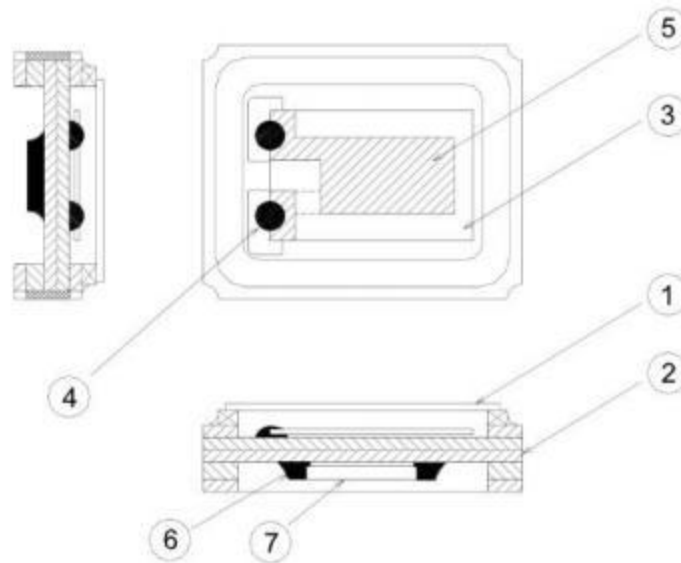

NO.	COMPONENTS	MATERIALS	QTY
1	Lid	Metal (Fe+Co+Ni)	1
2	Base(Package)	Al ₂ O ₃	1
3	Crystal blank	SiO ₂	1
4	Conductive adhesive	Ag+ Silicone resin	4
5	Electrode	Noble metal	2
6	Solder	Sn	2
7	Thermistor	Al ₂ O ₃ ,Ag ,Ni	1

● EMBOSS CARRIER TAPE & REEL

(unit: mm)

1. Dimension of taping and reel

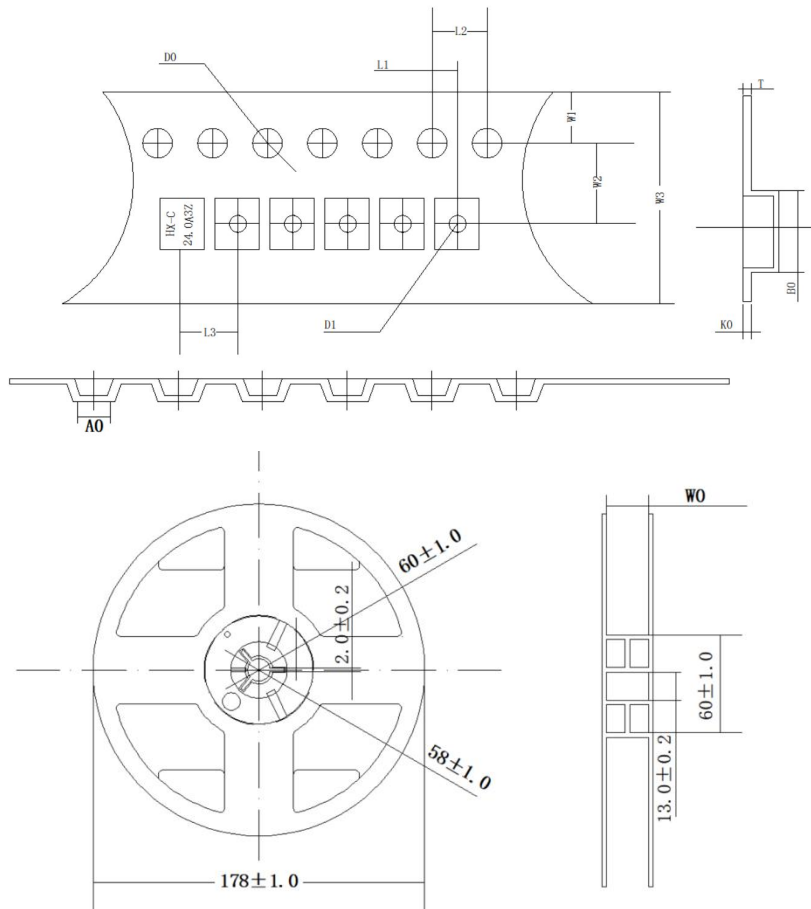

L1	2.00±0.1
L2	4.00±0.1
L3	4.00±0.1
D0	1.50±0.1
D1	1.00±0.1
W0	8.30±0.2
W1	1.75±0.1
W2	3.50±0.1
W3	8.00±0.1
A0	2.25±0.1
B0	2.70±0.1
K0	1.45±0.1
T	0.25±0.05

2. peel force of top cover tape shall be 0.2N to 1.0N

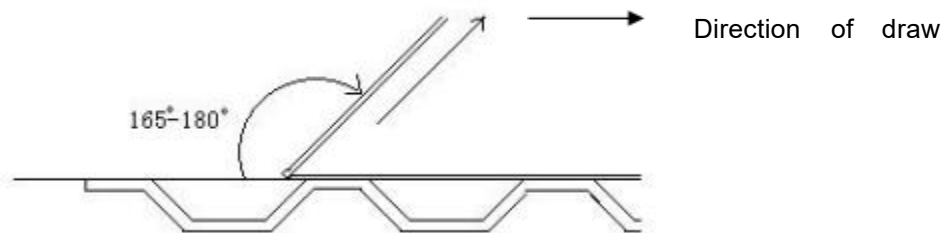

3. Packing

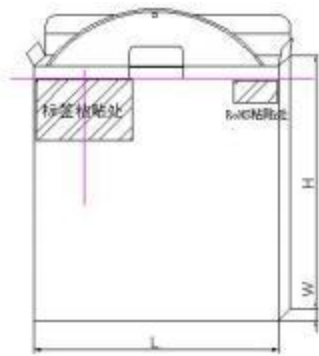

1 Reel/Inner Box

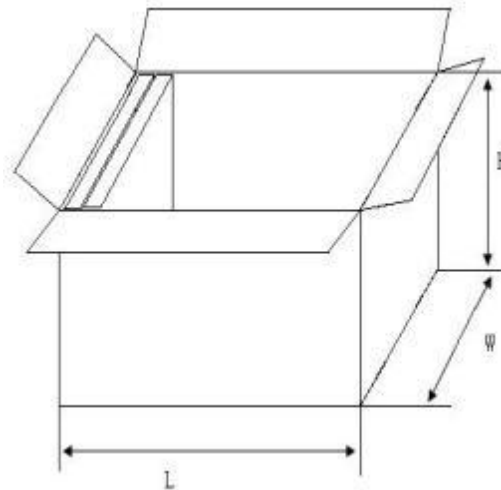

10 In-Boxer/Catton(Standard)

Package & Quantity

Type	Size (L*W*H)	Quantity
Inner Box	80*20*80	3000pcs
Catton	240*200*200	30000pcs

Standard Reel Quantity is 3000pcs per reel.

4. Contents of Packaging Labels

- * CUSTOMER No.
- * NOMINAL FREQUENCY
- * LOAD CAPA.
- * FREQ.TOLERANCE
- * ESR
- * DATE
- * LOT.
- * P/N
- * HOLDER TYPE
- * QUANTITY
- * MARKING

★ Remark

Customer specified requirements for marking , Labels, packaging, please provide the operation procedure.

● RELIABILITY SPECIFICATIONS

1. MECHANICAL ENDURANCE

No.	Test Item	Test Methods	Test Criteria
1	Drop Test	Electrical characteristics shall be satisfied after dropping three times from the height of 150cm onto the board of the 3cm thickness.	A、C
2	Mechanical Shock	Device are shocked to half sine wave (1000 G), duration time :0.5ms, and three mutually perpendicular axes each 3 times	A、C
3	Vibration	Frequency range 10 ~ 2000Hz Amplitude 1.52mm Sweep Time 20 min Direction x,y,z Test time 2hours/Each Direction	A、C
4	Solder ability	Temperature 245 °C +/- 5 °C Immersing depth 0.5 mm minimum Immersion time 3 +/- 0.5 seconds Flux Rosin resin methyl alcohol solvent (1 : 4)	E

2. ENVIRONMENTAL ENDURANCE

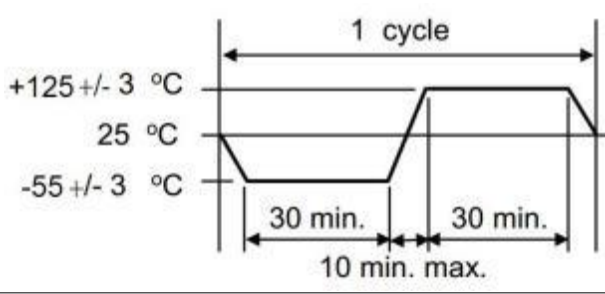
No.	Test Item	Test Methods	Test Criteria
5	Resistance To Soldering Heat	Pre-heat temperature 180 °C Pre-heat time 60 ~ 120 sec. Test temperature 260 +/- 5°C Test time 10 +/- 1 sec.	A、C、D
6	High Temp. Storage	+ 125 °C +/- 2 °C for 500 +/- 12 hours	A、C、D
7	Low Temp. Storage	-40 °C +/- 2 °C for 500 +/- 12 hours	A、C、D
8	Thermal Shock	Total 10 cycles of the following temperature cycle 	A、C、D
9	High Temp & Humidity	85°C +/- 3°C, RH 85%, 500Hrs	A、C、D

3. RELIABILITY SPECIFICATIONS

Specifications	
A	Frequency change: Within ± 5 ppm or in customer's specification.
B	Frequency change: Within ± 10 ppm or in customer's specification.
C	Effective resistance (RR) change: Within $\pm 20\%$ or 5Ω (larger value).
D	After conditioning, quartz crystal units shall be subjected to standard atmospheric conduction for 2 hour, and measured.
E	Minimum 95% of immersed terminal shall be covered with new uniform solder.