

BH12 Series

20A Current, Compact, Waterproof Power/Signal Hybrid Connector



Compact



High-Current



Waterproof



NEW

Overview

The BH12 Series is a power/signal hybrid connector ideal for the battery connection of micro-mobility applications. BH12 can also be used in other industrial applications as well. The BH12 Series is an IPX6/IPX7 waterproof connector (when mated) with lock lever design and enhances cable wiring efficiency. Additionally, the power/signal hybrid design contributes to reducing connector occupied mounting space.

Features

1. Compact connector with ϕ 13.8 diameter that supports high current up to 20A.

Although the total length is 36mm and the diameter is ϕ 13.8mm, BH12 is compatible with 14 AWG size cables and enables a high current of 20A.

Plug Outer Diameter : ϕ 13.8

Maximum Outer Diameter : ϕ 15.8

Mounting Dimensions

Front Mount Type : 23.1mm

Rear Mount Type : 13.6mm

(When using a 6mm panel)

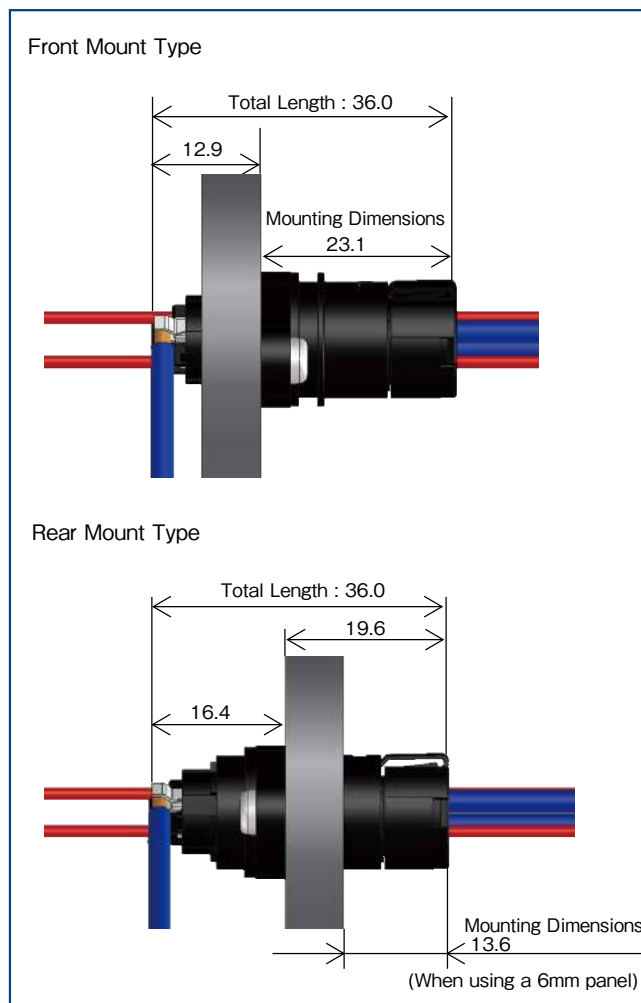

Mated State Diagram

2. The hybrid power/signal design enables application size reduction.

Connector occupied mounting space is reduced by combining power and signal. Supports Power 20Ax2pos., Signal 1Ax2pos. (or Signal 1Ax1pos.)

3. Waterproof Design

IPX6/IPX7 Waterproof Performance in the Mated State

IPX6 : Jet water of 100 L / min. in all directions from a distance of 3 m for 3 minutes in mated condition.

IPX7 : At a depth of 1m for 30 min.

(IPX8 class is also available)

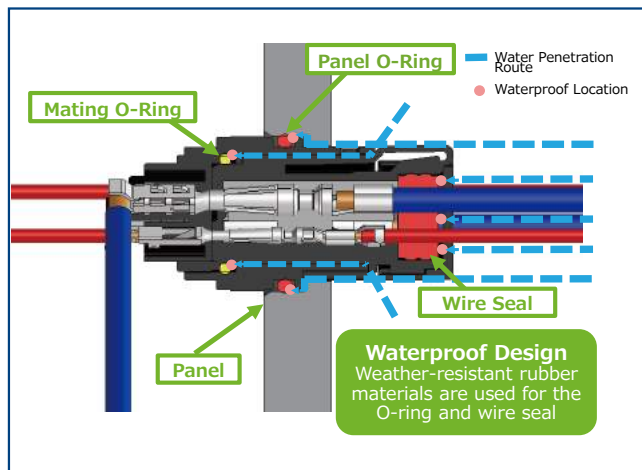

4. Lever lock for easy wiring.

The lock lever is locked in one action: simply push the plug straight into the receptacle. The lock lever on both sides of the plug prevents cable entanglement, lock deformation and damage during cable assembly and transportation.

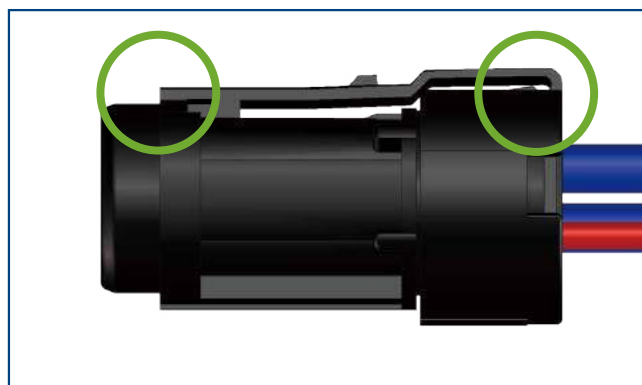

Lock Supports Both Ends

5. Easy cable assembly

The plug side utilizes Hirose's original design of inserting the contacts to the case from the side. It can be used with an overall short cable assembly length and no tools are required.

① Push through materials

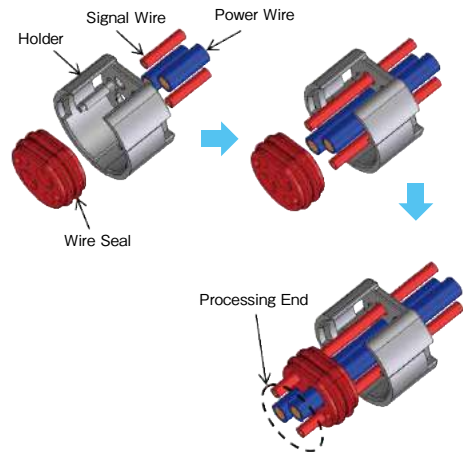

② Crimp

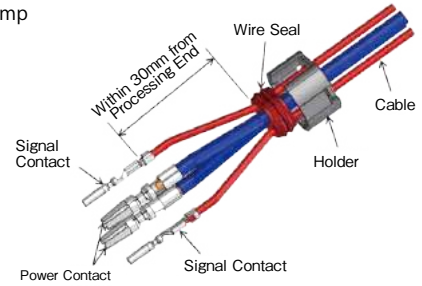

③ Insert into Contact Case

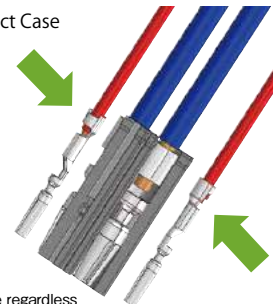

Assembly possible regardless of contact direction. The contact is secured to the case and does not come loose.

④ Insert Contact Case into Insulation Case

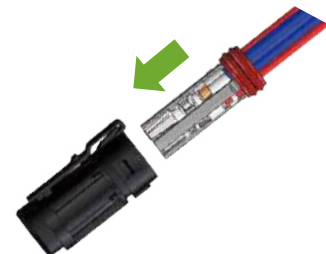

⑤ Completed



6. Mis-mating Prevention

Multiple guide keys for secure alignment and mating even in areas with poor visibility.

7. Light weight

The lightweight of 7g (plug+receptacle) contributes to equipment weight reduction as well as reduced power consumption of micro-mobility applications.

8. Both front and rear mount available

The receptacle is available in both front and rear mount types for selection based on the usage conditions. The front mount type is effective for reducing space used inside the panel. With the rear mount type, pre-assembled cable assemblies can be attached to the panel. Additionally, screws are not visible from the panel exterior.

9. Height inside panel is reduced by connecting the power contacts at a right angle.

The power contacts on the receptacle side are soldered at a right angle, contributing to height reduction inside the panel.

Product Specifications

Rated Current (Note 1)	Power Contact : 20A Signal Contact : 1A	Operating Temperature (Note 2)	-40 to +105°C
Rated Voltage	Power Contact : 30V AC, 42V DC Signal Contact : 30V AC, 42V DC	Storage Temperature Range	-10 to +60°C

Item	Specifications	Conditions
Contact Resistance	10mΩ Max. (Power Contact) 15mΩ Max. (Signal Contact)	1A DC
Insulation Resistance	1000MΩ Min.	500V DC
Withstanding Voltage	No flashover or insulation breakdown	600V AC for 2 min.
Mating Durability (Insertion / Withdrawal)	Contact Resistance : 10mΩ Max. (Power Contact) 15mΩ Max. (Signal Contact)	30 times
Vibration	No electrical discontinuity of 10 μs or more No damage, cracks, or parts dislocation	Frequency : 10 to 55 to 10Hz / cycles, Single Amplitude 0.75 mm, 5 min./ cycles, 10 cycles in each of the 3 directions
Shock	No electrical discontinuity of 10 μs or more No damage, cracks, or parts dislocation	Acceleration of 500m/s ² , duration of 11ms, sine half-wave waveform, 3 cycles in each of the 3 axes
Steady State Moisture Resistance	① Insulation Resistance : 10MΩ Min. (When high humidity) ② Insulation Resistance : 100MΩ Min. (When dry) No damage, cracks, or parts dislocation	96 hours at temperature of 40°C and humidity of 90 to 95%
Temperature Cycle	Insulation resistance : 100MΩ Min. No damage, cracks, or parts dislocation	Temperature : -40 → room temperature → +105°C → room temperature Time : 30 → 2 to 3 → 30 → 2 to 3 (Minutes) 5 cycles
Waterproof	No water inside the connector	IPX7 : At a water depth of 1m for 30 minutes in mated condition. IPX6 : Jet water of 100L / min. in all directions from a distance of 3m for 3 minutes in mated condition.

Note 1 : Depends on the ambient temperature at which the connector is used.

Note 2 : Includes the temperature rise due to current flow.

[Reference] Derating Curve

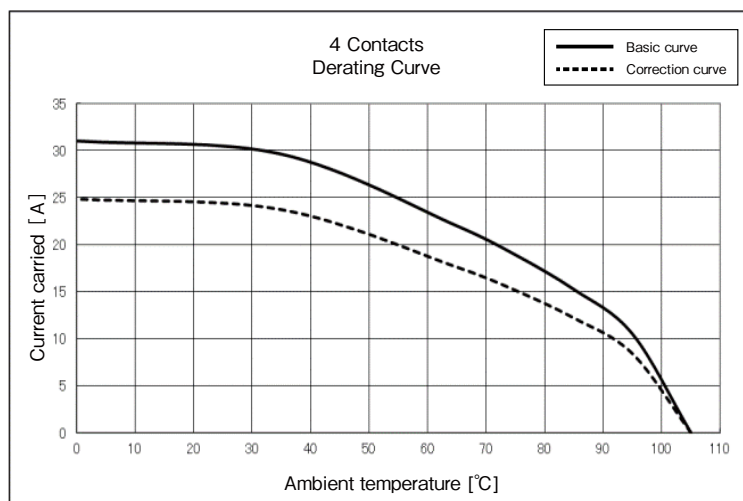

Note 1 : The derating curve is derived from the basic curve multiplied by the derating factor of 0.8.

Note 2 : The rated current varies depending on the ambient temperature at which the connector is used in. We recommend using it within the correction curve (dotted line).

Note 3 : The measurement method of the derating curve is shown below.

- Test specimen : BH12 unused prior to testing.
- Test cable conductor cross sectional area :
 - Power 14 AWG (1.946mm²)
 - Signal 22 AWG (0.372mm²)
- Power supplied while the specimen is in a stationary state and then measured.

Materials / Finish

Item	Component	Materials	Color / Finish	UL Standard
Plug	Insulation Case	PBT	Black	UL94V-0
	Contact Case			
	Holder A			
	Holder B			
	Wire Seal			
Receptacle	Housing	PBT	Black	UL94V-0
	O-ring A	Silicone Rubber	Yellow	-
	O-ring B		Red	-
Crimp Contact	Female Power Contact	Copper Alloy	Tin Plating	-
	Female Signal Contact			
Solder Contact	Male Power Contact	Copper Alloy	Tin Plating	-
	Male Signal Contact			

Product Number Structure

Refer to the chart below when determining the product specifications from the product number.
Please select from the product numbers listed in this catalog when placing orders.

● Connector

BH12 W P - 4 S C

① ② ③ ④ ⑤ ⑥

① Series Name	BH12	④ No. of Pos.	3, 4
② Special Features	W : Waterproof	⑤ Contact Gender	S : Female Contact P : Male Contact
③ Connector Type	P : Plug R : Receptacle (Front Mount) RA : Receptacle (Rear Mount)	⑥ Contact Termination Method	N/A : Soldering C : Crimping

● Contact

BH12 - S C 1 - 2 1 3

① ② ③ ④ ⑤ ⑥ ⑦

① Series Name	BH12	④ Contact Type	N/A : Power Contact 1 : Signal Contact
② Contact Gender	S : Female Contact P : Male Contact	⑤ Packaging	2 : Reel Contact
③ Contact Termination Method	N/A : Soldering C : Crimping	⑥ Design	1 : Denotes the compatible wire gauge and are identified by 1, 2, 3, etc.
		⑦ Contact Portion Plating	3 : Tin Plating

Plug

●4pos. (Power 2pos. + Signal 2pos.)

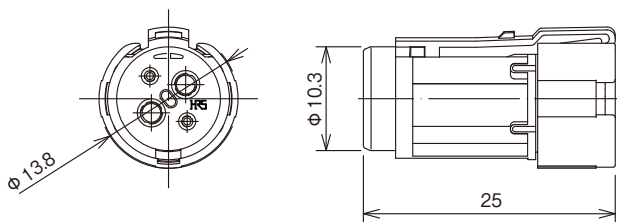

Part No.	HRS No.	No. of Pos.	Purchase Unit
BH12WP-4SC	CL0140-0010-0-00	4	100pcs per bag

●3pos. (Power 2pos. + Signal 1pos.)

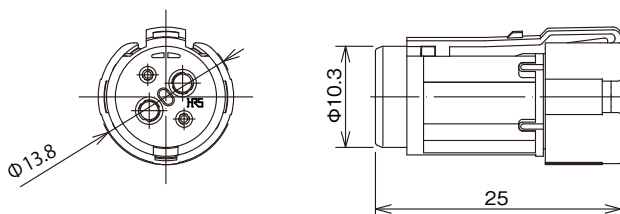

Part No.	HRS No.	No. of Pos.	Purchase Unit
BH12WP-3SC	CL0140-0011-0-00	3	100pcs per bag

Note : The 3pos. plug mates with the 4pos. receptacle.

Receptacle

●Front Mount Type

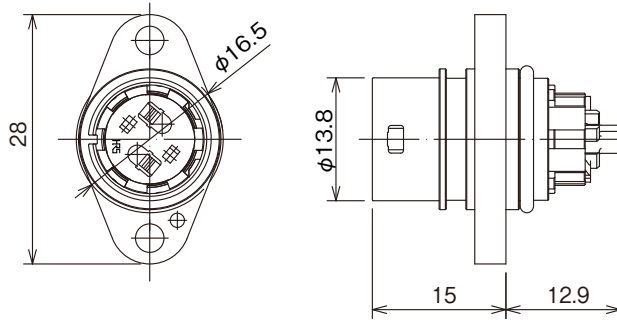

Recommended Panel Mounting Dimensions (Recommended Panel Thickness : 6-7.5mm)

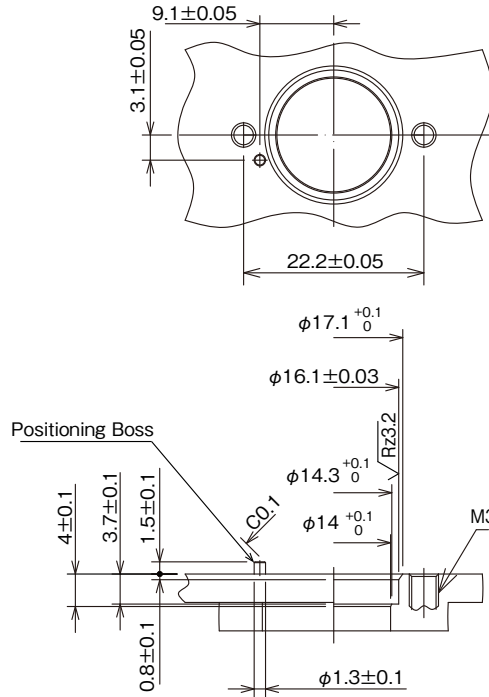

Part No.	HRS No.	No. of Pos.	Purchase Unit
BH12WR-4P	CL0140-0012-0-00	4	50pcs per tray

Note : For 3pos. (power 2pos.+ signal 1pos.), insert only 1 signal contact.

●Rear Mount Type

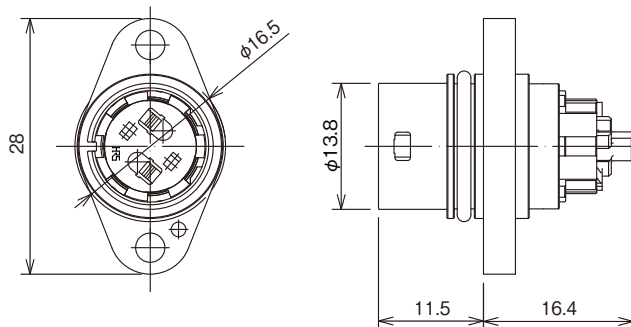

Recommended Panel Mounting Dimensions
(Recommended Panel Thickness : 6-7.5mm)

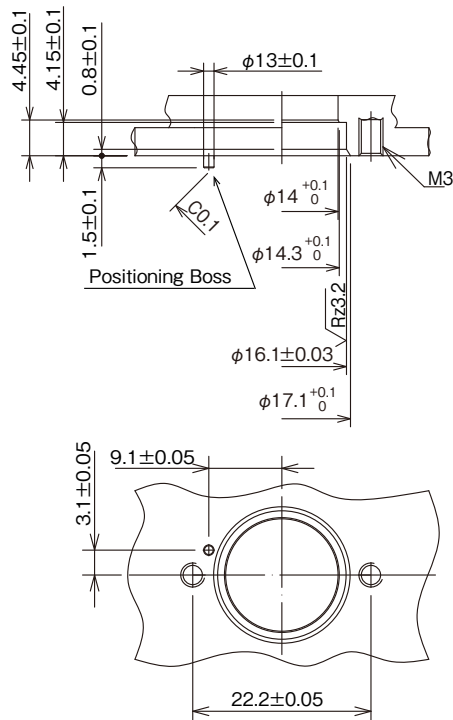

Part No.	HRS No.	No. of Pos.	Purchase Unit
BH12WRA-4P	CL0140-0013-0-00	4	50pcs per tray

Note : For 3pos. (power 2pos.+ signal 1pos.), insert only 1 signal contact.

Plug Crimp Contact

●Female Power Contact

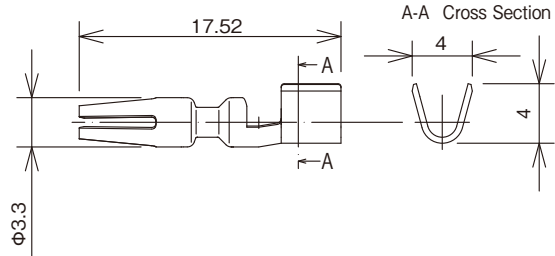

Part No.	HRS No.	Applicable Wire	Purchase Unit
BH12-SC-213	CL0140-0014-0-00	14-16 AWG, Outer Diameter ϕ 2.6-3.0	5,000pcs per reel

●Female Signal Contact

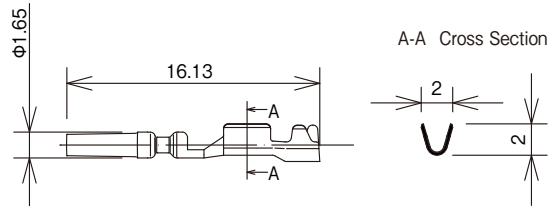

Part No.	HRS No.	Applicable Wire	Purchase Unit
BH12-SC1-213	CL0140-0015-0-00	22-24 AWG, Outer Diameter ϕ 2.6-3.0	10,000pcs per reel

Receptacle Solder Contact

● Male Power Contact

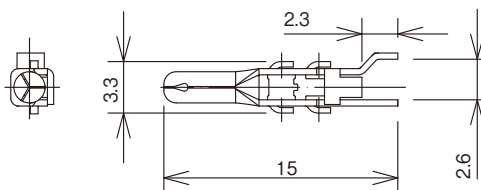

Part No.	HRS No.	Applicable Wire	Purchase Unit
BH12-P-213	CL0140-0016-0-00	14-16 AWG, Outer Diameter ϕ 2.6-3.0	5,000pcs per reel

● Male Signal Contact

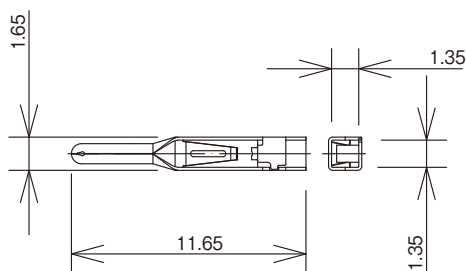

Part No.	HRS No.	Applicable Wire	Purchase Unit
BH12-P1-213	CL0140-0017-0-00	22-24 AWG, Outer Diameter ϕ 1.4-1.6	10,000pcs per reel

Applicable Tools

Item	Type	Part No.	HRS No.	Applicable Contact	Applicable Wire
Crimping Tool	Automatic Crimp Press	CM-105C	CL0901-0001-0-00	-	-
	Applicator	AP105-BH12-SC-1	CL0901-2057-0-00	BH12-SC-213	14-16 AWG Outer Diameter φ 2.6-3.0
		AP105-BH12-SC1-1	CL0901-2058-0-00	BH12-SC1-213	22-24 AWG Outer Diameter φ 1.4-1.6
	Manual Crimp Tool	HT804/BH12-SC-1	CL0150-0409-0-00	BH12-SC-213	AVSS2.0
		HT802/BH12-SC1-1	CL0150-0410-0-00	BH12-SC1-213	AVSS0.3
Soldering Tool	Soldering Base	BH12-P-213/SO/MD	CL0902-1525-0-00	BH12-P-213	14-16 AWG Outer Diameter φ 2.6-3.0
		BH12-P1-213/SO/MD	CL0902-1526-0-00	BH12-P1-213	22-24 AWG Outer Diameter φ 1.4-1.6

Crimping Precautions

■ Items Required Prior to Crimping

The work-related documents shown below are required before starting the harness assembly.

(The ● mark represents required documents.)

Please contact your Hirose sales representative if you do not have these documents.

Document Title	Description	Automatic Crimping Machine	Hand Crimping Tool	Remarks
(1) Main unit of crimping machine instruction manual	Explanation for main press machine unit	●	—	Bundled with the purchase of the main press machine unit.
(2) Applicator Spare Parts Identification	Explanation for Applicator installation	●	—	Bundled with the purchase of applicator.
(3) Crimp Conditions	Standard values of : Crimp height Tensile strength	●	—	
(4) Crimp Quality Standards	Various standards for crimping conditions	●	—	
(5) Operating Instructions for Hand Tool	Inspection items of : Crimp height Tensile strength and others	—	●	Bundled with the purchase of hand tool.
(6) Harness Procedure Manual BH12 Series : ETAD-C0454-00	Harness procedure	●	●	Ask a HRS sales representative.

■ Tools

- Use tools designated by Hirose when crimping.
- Crimping performed using tools other than those specified is outside the scope of warranty.
- The operating instructions are available for the crimping machine and the applicator. Be sure to carefully read the operating instructions manual before beginning work.

■ Applicable Cables

Check that the cables to be used are within the applicable range.

If you intend to use a cable other than those recommended, contact a sales representative.

[Precautions]

- Cables applicable to crimp connectors are tin-plated stranded soft-copper wire.
- Avoid crimping solid wire, wires with polyester threads or tin coated wires.
- Avoid crimping two cables together.
- The crimp height setting values (Note) may vary depending on the difference in the core wire configuration even if the computed cross-sectional area is the same.

Note : The crimp height is an important item that determines crimp quality. Hirose conducts crimp testing on each wire in order to set the optimum crimp height accurately.

Precautions when using Connectors

1. When assembling the connector and installing to equipment, refer to the separate procedure manual and drawings. Please also make sure to use the specified tightening torque. If the torque is too low or high, it may result in loosening or product damage. (Contact a Hirose sales representative for the procedure manual.)
2. Once mated, pull lightly on the cable to confirm the mated status and that the connector does not come off.
3. Excessive external force applied to the connector may cause deformation or damage, resulting in poor conduction or waterproofing performance issues. Please avoid forceful insertion/removal, impact and pulling, routing or twisting of the cables. Also, when routing inside equipment, make sure to provide sufficient slack to the cable so that a load is not applied directly to the connector such as through excessive cable bending or tension on the cable.
4. When packing and storing assembled products, make sure not to apply excessive load on the spring portion of the plug insulation case due to connector overlapping. If the lock is left in a high temperature and high humidity environment for a long period of time with a load applied, the lock may deform resulting in mating failure.
5. Damage of the waterproof seal or waterproof surface may result in issues with the waterproof performance, so please refrain from using a damaged product.

While Taking into Consideration

Specifications mentioned in this catalog are reference values.

When considering to order or use this product, please confirm the Drawing and Product Specifications sheets.

Use an appropriate cable when using the connector in combination with cables.

If considering usage of a non-specified cable, please contact your sales representative.

If assembly process is done by jigs & tools which are not identified by Hirose, assurance will not be given.

If considering usage for below mentioned applications, please contact your sales representative.

In cases where the application will demand a high level of reliability, such as automotive, medical instruments, public infrastructure, aerospace/ defense etc. Hirose must review before assurance of reliability can be given.