

### Product Summary

$V_{(BR)DSS}$	$R_{DS(on)TYP}$	$I_D@25^{\circ}C$
1200V	28mΩ@18V	88A

### Feature

- Wide bandgap SiC MOSFET technology
- Low On-Resistance with High Blocking Voltage
- Low Capacitance with High-Speed switching
- Low reverse recovery(Qrr)

### Application

- Switch Mode Power Supplies
- Renewable energy
- Motor drives
- High Voltage DC/DC Converters

### Package

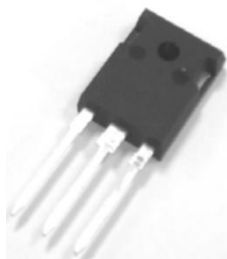

TO-247-3

### Marking



### Circuit diagram

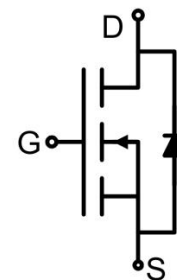

### Absolute maximum ratings (Tc=25°C unless otherwise noted)

Parameter	Symbol	Test Condition	Value	Unit
Drain-Source Voltage	$V_{DSmax}$	$V_{GS}=0V, I_D = 100\mu A$	1200	V
Gate-Source Voltage	$V_{GSmax}$	AC (f > 1Hz)	-10/+25	V
Gate-Source Voltage	$V_{GSOP}$	Static	-4/+18	V
Continuous Drain Current	$I_D$	$V_{GS}=18V, T_C=25^{\circ}C$	88	A
	$I_D$	$V_{GS}=18V, T_C=100^{\circ}C$	62	A
Peak Drain Current	$I_{DM}$	Pulse width $t_p$ limited by $T_{JMAX}$	175	A
Power Dissipation	$P_D$	$T_C=25^{\circ}C$	500	W
Thermal Resistance (Typ)	$R_{\theta JC}$	Junction-to-Case	0.3	°C/W
Junction Temperature	$T_J$		-55 ~ +175	°C
Storage Temperature	$T_{STG}$		-55 ~ +175	°C

### Electrical characteristics (T<sub>J</sub>=25°C unless otherwise noted)

Parameter	Symbol	Test Condition	Min.	Typ.	Max.	Unit
<b>Static Characteristics</b>						
Drain-source breakdown voltage	V <sub>(BR)DSS</sub>	V <sub>GS</sub> = 0V, I <sub>D</sub> = 100μA	1200			V
Zero gate voltage drain current	I <sub>DSS</sub>	V <sub>DS</sub> = 1200V, V <sub>GS</sub> = 0V		1	50	μA
Gate-Source leakage current	I <sub>GSS</sub>	V <sub>GS</sub> = 18V, V <sub>DS</sub> = 0V			250	nA
Gate threshold voltage	V <sub>GS(th)</sub>	V <sub>DS</sub> = V <sub>GS</sub> , I <sub>D</sub> = 12mA		3.0		V
		V <sub>DS</sub> = V <sub>GS</sub> , I <sub>D</sub> = 12mA, T <sub>J</sub> = 175°C		2.0		
Drain-source on-resistance	R <sub>DS(on)</sub>	V <sub>GS</sub> = 18V, I <sub>D</sub> = 40A		28	42	mΩ
		V <sub>GS</sub> = 20V, I <sub>D</sub> = 40A		25		
		V <sub>GS</sub> = 18V, I <sub>D</sub> = 40A, T <sub>J</sub> = 175°C		66		
		V <sub>GS</sub> = 20V, I <sub>D</sub> = 40A, T <sub>J</sub> = 175°C		62		
Transconductance	g <sub>fs</sub>	V <sub>GS</sub> = 18V, I <sub>D</sub> = 40A		38		S
		V <sub>GS</sub> = 18V, I <sub>D</sub> = 40A, T <sub>J</sub> = 175°C		24		
<b>Dynamic characteristics</b>						
Input Capacitance	C <sub>iss</sub>	V <sub>DS</sub> = 1000V, V <sub>GS</sub> = 0V, f = 1MHz V <sub>AC</sub> = 25mV		3290		pF
Output Capacitance	C <sub>oss</sub>			124		
Reverse Transfer Capacitance	C <sub>rss</sub>			7.8		
Turn-on Switching Energy	E <sub>on</sub>	V <sub>DS</sub> = 800V, V <sub>GS</sub> = -4V/18V, I <sub>D</sub> = 40A, R <sub>G(int)</sub> = 5Ω, L = 276nH		431		μJ
Turn-off Switching Energy	E <sub>off</sub>			158		
Total switching energy	E <sub>tot</sub>			589		
Total Gate Charge	Q <sub>g</sub>	V <sub>DS</sub> = 800V, V <sub>GS</sub> = -4V/18V, I <sub>D</sub> = 40A		133		nC
Gate-Source Charge	Q <sub>gs</sub>			26		
Gate-Drain Charge	Q <sub>gd</sub>			33		
Turn-on delay time	t <sub>d(on)</sub>	V <sub>DS</sub> = 800V, V <sub>GS</sub> = -4V/18V, I <sub>D</sub> = 40A, R <sub>G(int)</sub> = 5Ω, L = 276nH		15		nS
Turn-on rise time	t <sub>r</sub>			22		
Turn-off delay time	t <sub>d(off)</sub>			31		
Turn-off fall time	t <sub>f</sub>			13		
Internal Gate Resistance	R <sub>G</sub>	f = 1MHz, V <sub>AC</sub> = 25mV		1		Ω
<b>Source-Drain Diode characteristics</b>						
Diode Forward Current	I <sub>S</sub>	V <sub>GS</sub> = -4V, T <sub>C</sub> = 25°C		97		A
Diode Forward voltage	V <sub>SD</sub>	V <sub>GS</sub> = -4V, I <sub>SD</sub> = 20A		3.8		V
		V <sub>GS</sub> = -4V, I <sub>SD</sub> = 20A, T <sub>J</sub> = 175°C		3.3		
Reverse Recovery Time	t <sub>rr</sub>	V <sub>GS</sub> = -4V, I <sub>SD</sub> = 40A, V <sub>R</sub> = 800V		15		nS
Reverse Recovery Charge	Q <sub>rr</sub>	dif/dt = 3800A/μs		213		nC

## Typical Characteristics

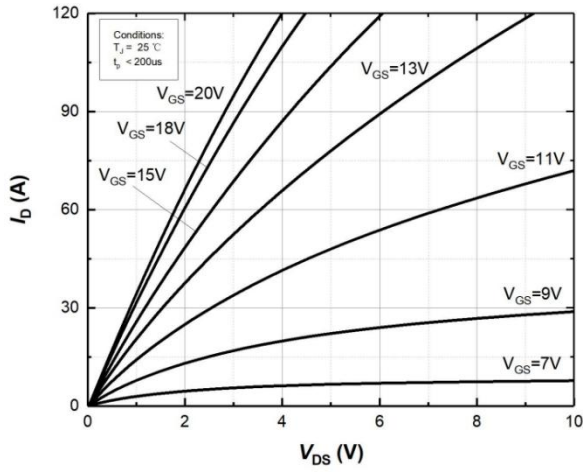

Figure 1. Output characteristics at  $T_j=25^\circ\text{C}$

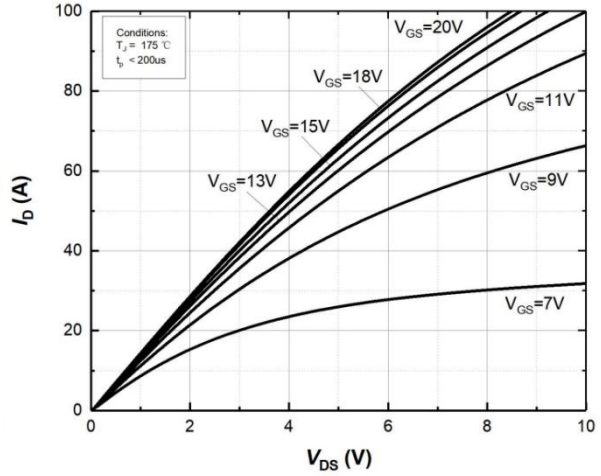

Figure 2. Output characteristics at  $T_j=175^\circ\text{C}$

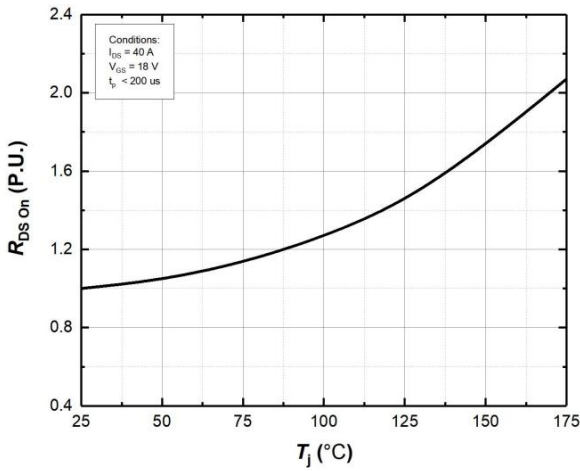

Figure 3. Normalized On-Resistance vs. Temperature

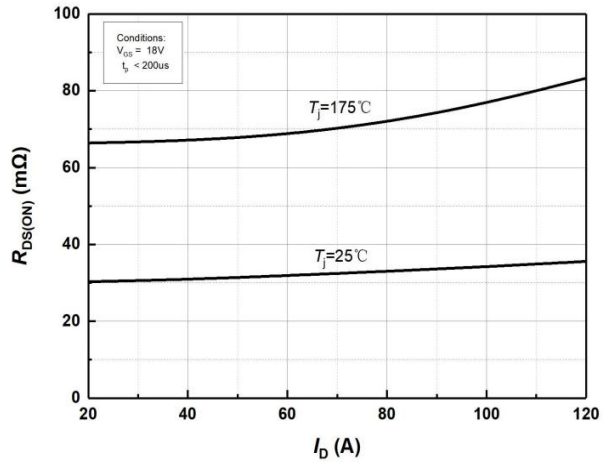

Figure 4. On-Resistance vs. Drain current for Various Temperature

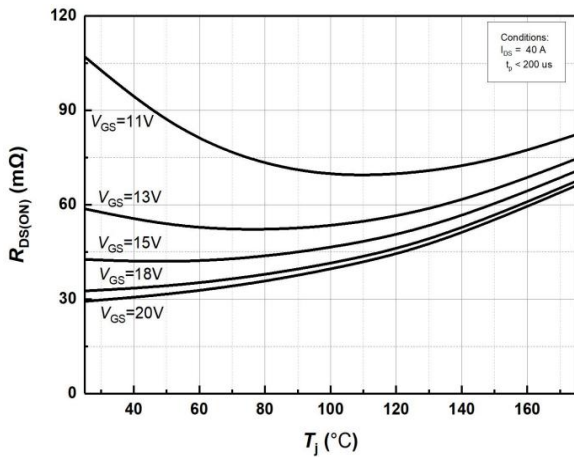

Figure 5. On-Resistance vs. Temperature for Various Gate Voltage

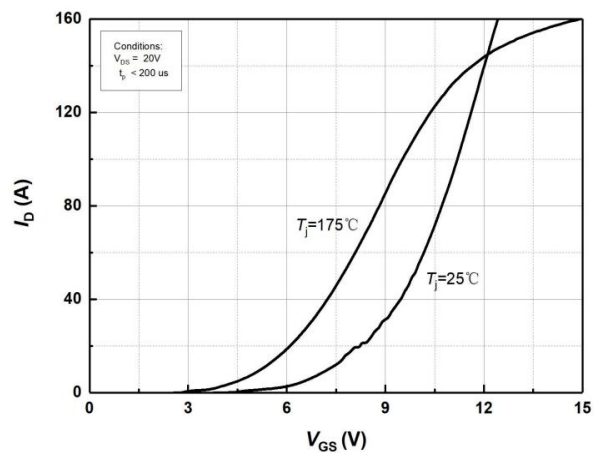

Figure 6. Transfer Characteristics for Various Junction Temperatures

## Typical Characteristics

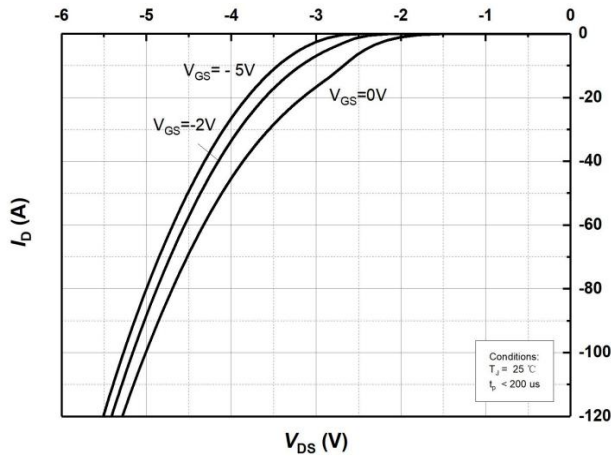

Figure 7. Body Diode Characteristics at Tj=25°C

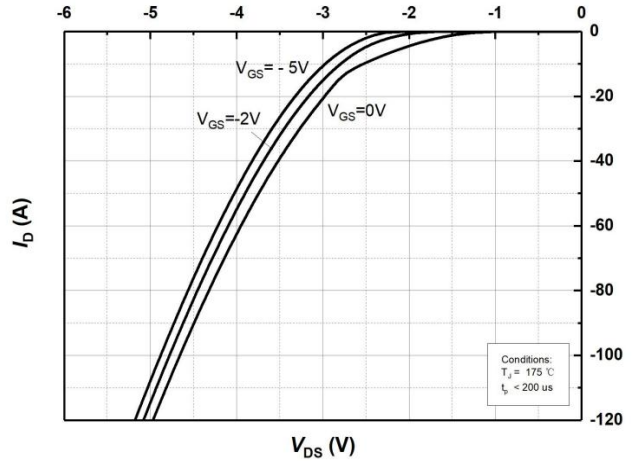

Figure 8. Body Diode Characteristics at Tj=175°C

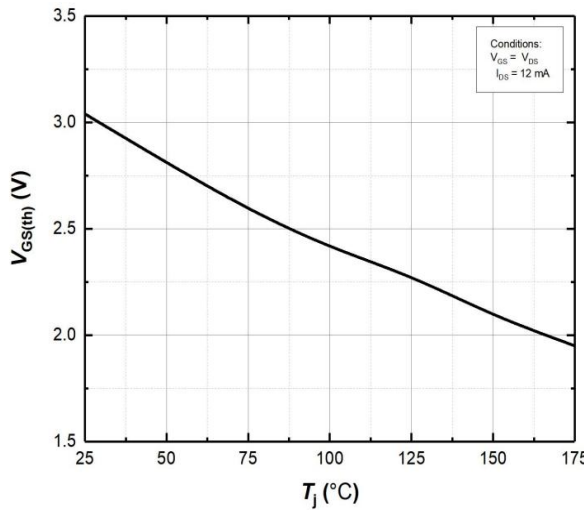

Figure 9. Threshold Voltage vs. Temperature

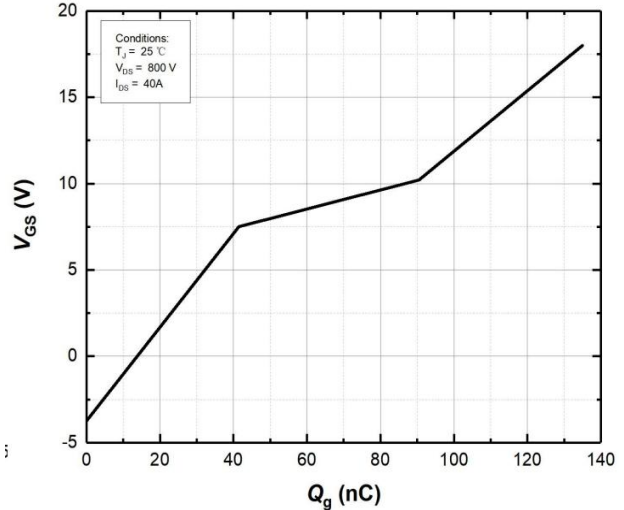

Figure 10 Gate Charge Characteristics

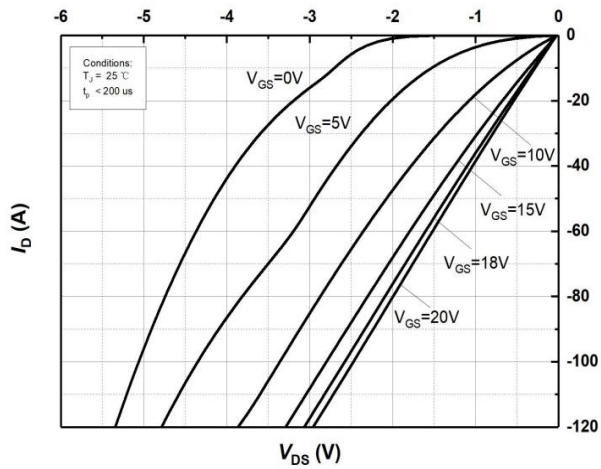

Figure 11. 3rd Quadrant Characteristic at Tj=25°C

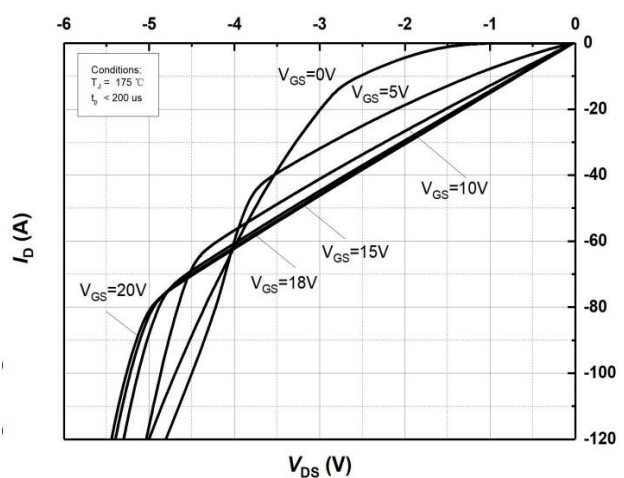

Figure 12. 3rd Quadrant Characteristic at Tj=175°C



## Typical Characteristics

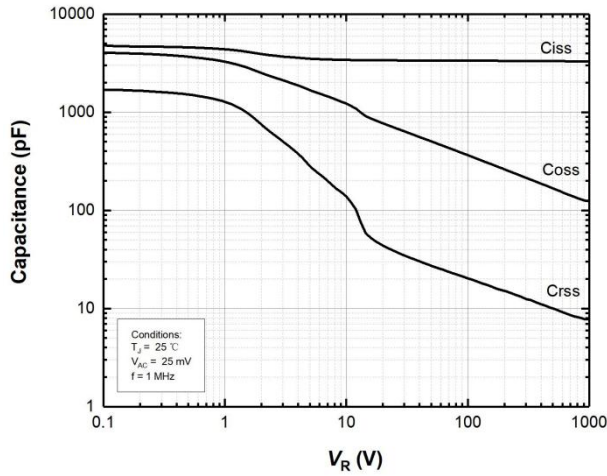

Figure 13. Capacitances vs. Drain-Source Voltage (0 – 1000V)

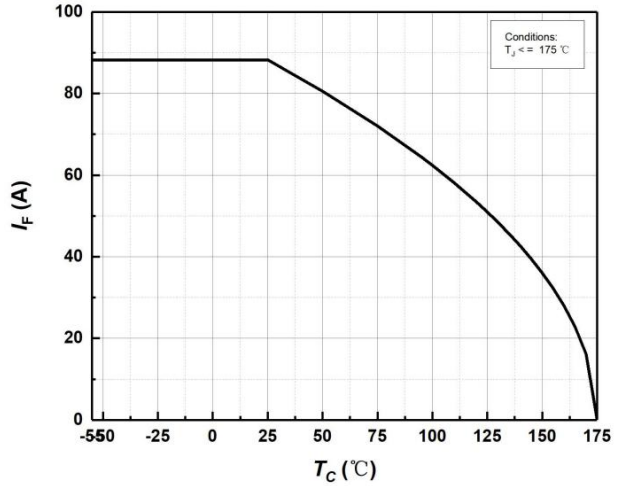

Figure 14. Continuous Drain Current Derating vs Case Temperature

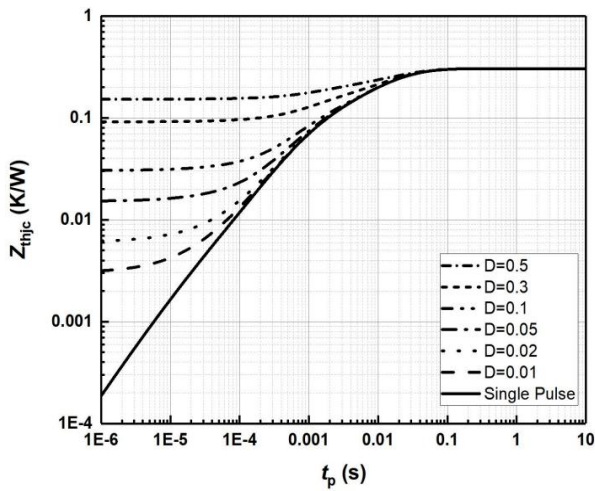

Figure 15. Transient Thermal Impedance (Junction – Case)

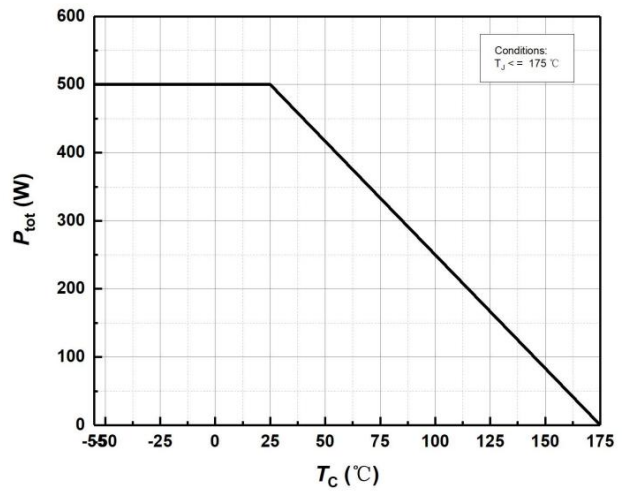

Figure 16. Maximum Power Dissipation Derating vs. Case Temperature

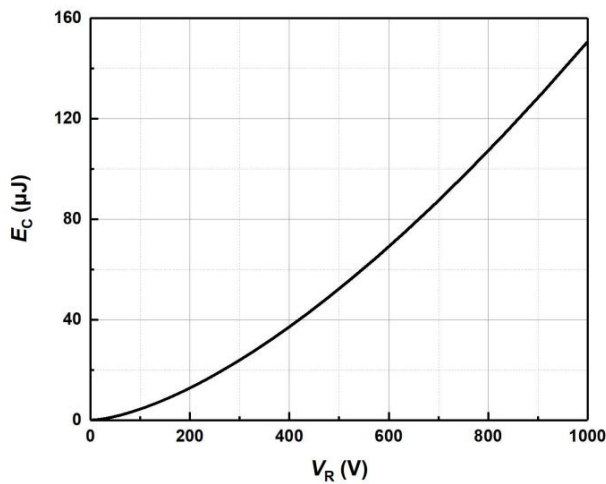

Figure 17. Output Capacitor Stored Energy

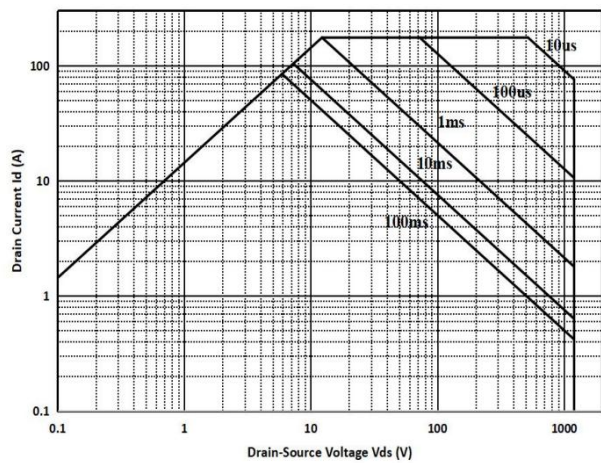

Figure 18. Safe Operating Area

## Typical Characteristics

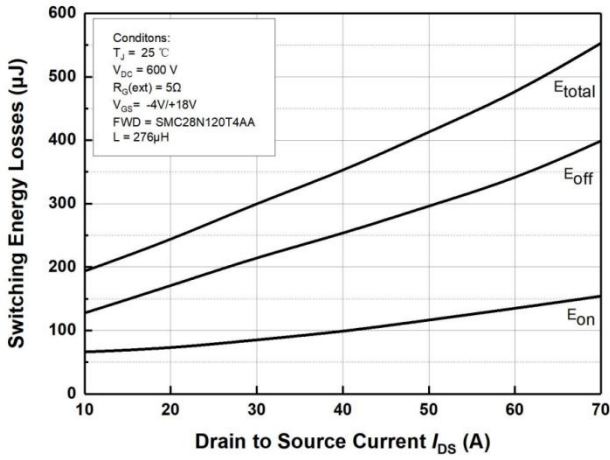

Figure 19. Clamped Inductive Switching Energy vs. Drain Current ( $V_{DD} = 600V$ )

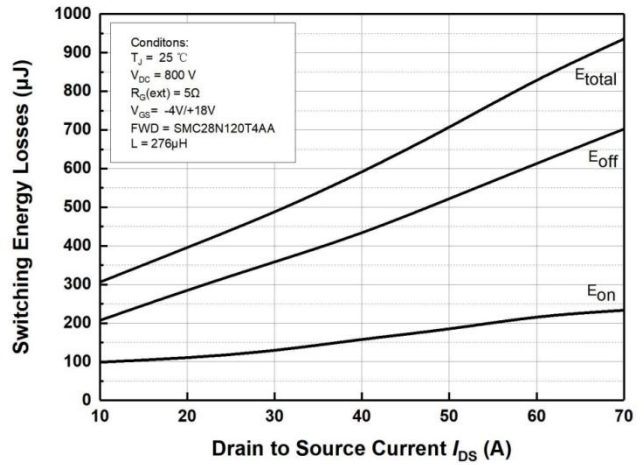

Figure 20. Clamped Inductive Switching Energy vs. Drain Current ( $V_{DD} = 800V$ )

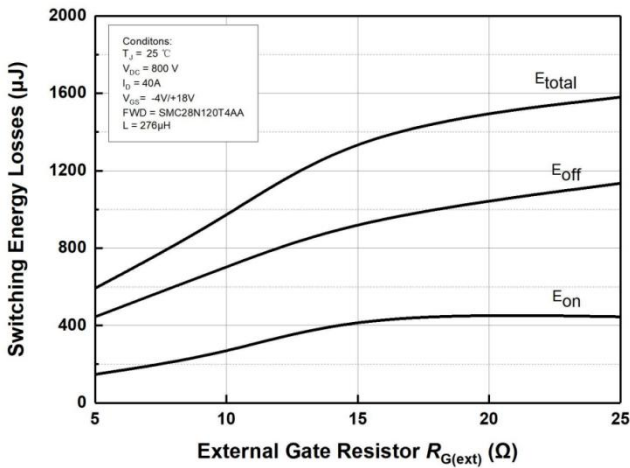

Figure 21. Clamped Inductive Switching Energy vs.  $R_{G(ext)}$

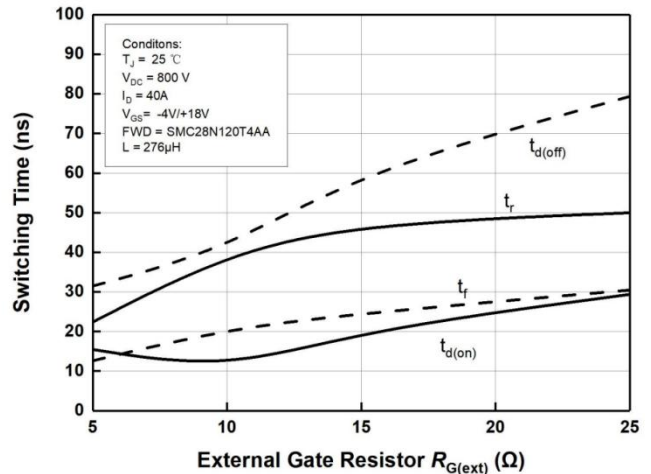
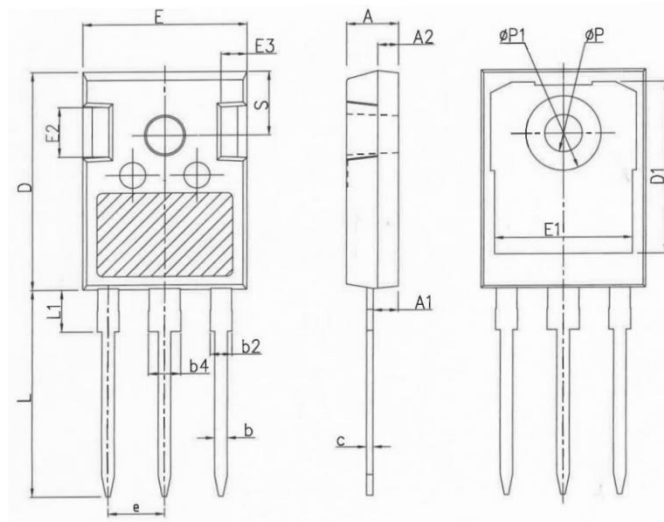

Figure 22. Switching Times vs.  $R_{G(ext)}$

### TO-247-3 Package Information



Symbol	Dimensions In Millimeters		Dimensions In Inches	
	Min.	Max.	Min.	Max.
A	4.800	5.200	0.189	0.205
A1	2.210	2.590	0.087	0.102
A2	1.850	2.150	0.073	0.085
b	1.110	1.360	0.044	0.054
b2	1.910	2.210	0.075	0.087
b4	2.910	3.210	0.115	0.126
c	0.510	0.750	0.020	0.030
D	20.700	21.300	0.815	0.839
D1	16.250	16.850	0.640	0.663
E	15.500	16.100	0.610	0.634
E1	13.000	13.600	0.512	0.535
E2	4.800	5.200	0.189	0.205
E3	2.300	2.700	0.091	0.106
e	5.440 BSC		0.214 BSC	
L	19.620	20.220	0.772	0.796
L1	-	4.300	-	0.169
φP	3.400	3.800	0.134	0.150
φP1	-	7.300	-	0.287
S	6.150 BSC		0.242 BSC	