

N-Channel 80V MOSFET

E080N6P5CL1

V_{DS} (V)	$R_{DS(on),max}$ (m Ω)	I_D (A)
80V	6.5@ $V_{GS} = 10V$	70

Features

- Low $R_{DS(on)}$ trench technology
- Low thermal impedance
- Fast switching speed
- 100% avalanche tested

Applications

- DC/DC conversion
- Power switch
- PD charger
- Moto driver

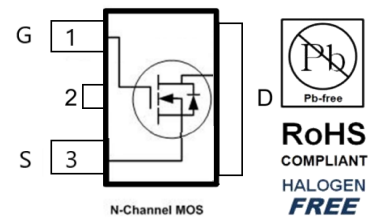
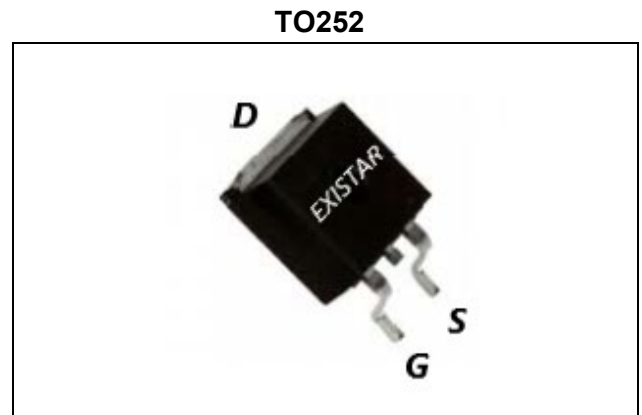

Package And Ordering Information

Ordering code	Package	Marking
E080N6P5CL1	TO252	E080N6P5CL1

Ordering Information

Package	Units/ Reel	Reels/ Inner Box	Units/ Inner Box
TO252	2500	2	5000

Key Performance Parameters

Parameter	Value	Unit
VDS, min @ Tj(max)	80	V
ID, pulse	275	A
RDS(ON), max @ VGS=10V	6.5	mΩ
Qg	41.7	nC

Absolute Maximum Ratings at Tj=25°C Unless Otherwise Noted

Parameter	Symbol	Limit	Unit
Drain-source voltage	V _{DS}	80	V
Gate-source voltage	V _{GS}	±20	
Continuous drain current	I _D	T _C =25°C	70
		T _C =100°C	45
Pulsed drain current	I _{D,pulse}	275	A
Avalanche energy, single pulse	E _{AS}	20	mJ
Power dissipation	P _D	T _C =25°C	57.6
		T _A =25°C	-
Operating junction and storage temperature range	T _J , T _{stg}	-55 to 150	°C

Thermal Characteristics

Parameter	Symbol	Max.	Unit
Thermal resistance, junction-to-case	R _{θJC}	2.2	°C/W
Thermal resistance, junction-to-ambient	R _{θJA}	62	

Electrical Characteristics at Tj=25°C unless otherwise specified

Parameter	Symbol	Min.	Typ.	Max.	Unit	Test conditions
Static						
Drain to source breakdown voltage	V _{(BR)DSS}	80			V	V _{GS} = 0, I _D = 250 μA
Gate-source threshold voltage	V _{GS(th)}	1.2	1.8	2.5	V	V _{DS} = V _{GS} , I _D = 250 μA
Gate-body leakage	I _{GSS}			±100	nA	V _{DS} = 0 V, V _{GS} = ±20 V
Zero gate voltage drain current	I _{DSS}			1	μA	V _{DS} = 64 V, V _{GS} = 0 V
Drain-source on-resistance	R _{DS(on)}		5.3	6.5	mΩ	V _{GS} = 10 V, I _D = 20 A
Drain-source on-resistance	R _{DS(on)}		7.8	8.8	mΩ	V _{GS} = 4.5 V, I _D = 15 A

Forward transconductance	g_{fs}				S	$V_{DS} = 5\text{ V}, I_D = 20\text{ A}$
Gate resistance	R_g		0.7		Ω	$f = 1\text{ MHz}$
Gate Charge						
Total gate charge	Q_g		41.7		nC	$V_{DS} = 40\text{ V}, I_D = 20\text{ A}, V_{GS} = 10\text{ V}$
Gate-source charge	Q_{gs}		9.2			
Gate-drain charge	Q_{gd}		7.7			
Dynamic						
Turn-on delay time	$t_{d(on)}$		8.4		ns	$V_{DS} = 40\text{ V}, I_D = 20\text{ A}, V_{GS} = 10\text{ V}, R_{GEN} = 3.6\ \Omega$
Rise time	t_r		21			
Turn-off delay time	$t_{d(off)}$		29			
Fall time	t_f		45			
Input capacitance	C_{iss}		1721		pF	$V_{DS} = 30\text{ V}, V_{GS} = 0\text{ V}, f = 1\text{ MHz}$
Output capacitance	C_{oss}		812			
Reverse transfer capacitance	C_{rss}		47			
Body Diode						
Diode forward voltage	V_{SD}			1.2	V	$V_{GS} = 0\text{ V}, I_F = 20\text{ A}$
Reverse recovery time	t_{rr}		25		ns	$V_R = 30\text{ V}, I_S = 20\text{ A}, di/dt = 200\text{ A}/\mu\text{s}$
Reverse recovery charge	Q_{rr}		45		nC	

Electrical Characteristics Diagrams

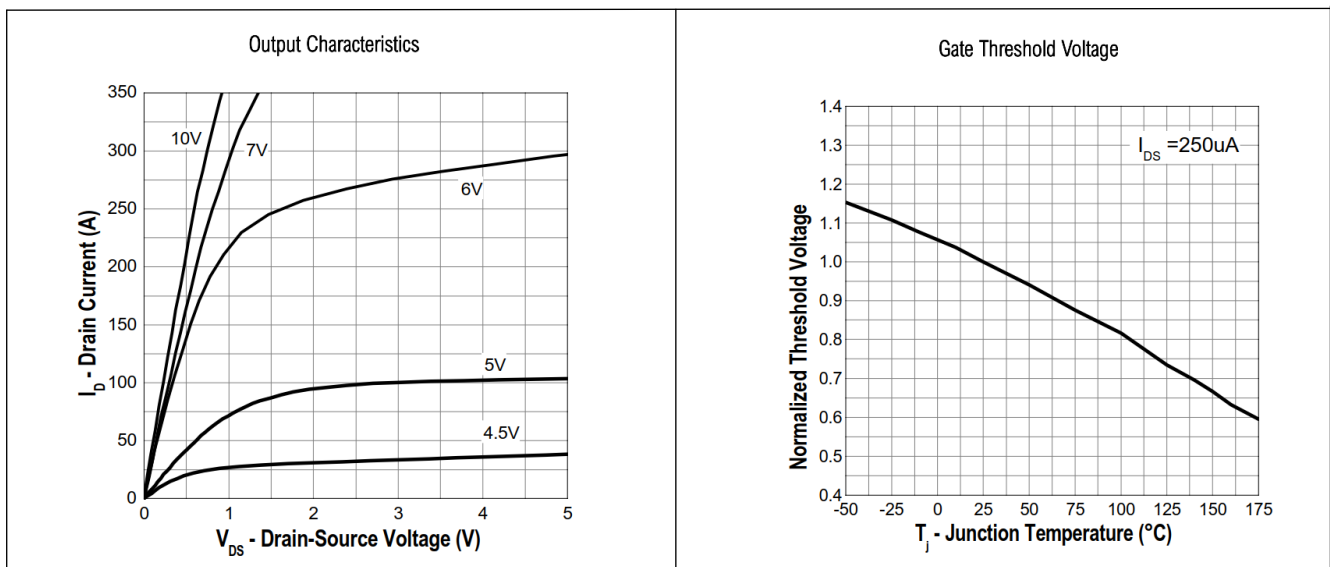

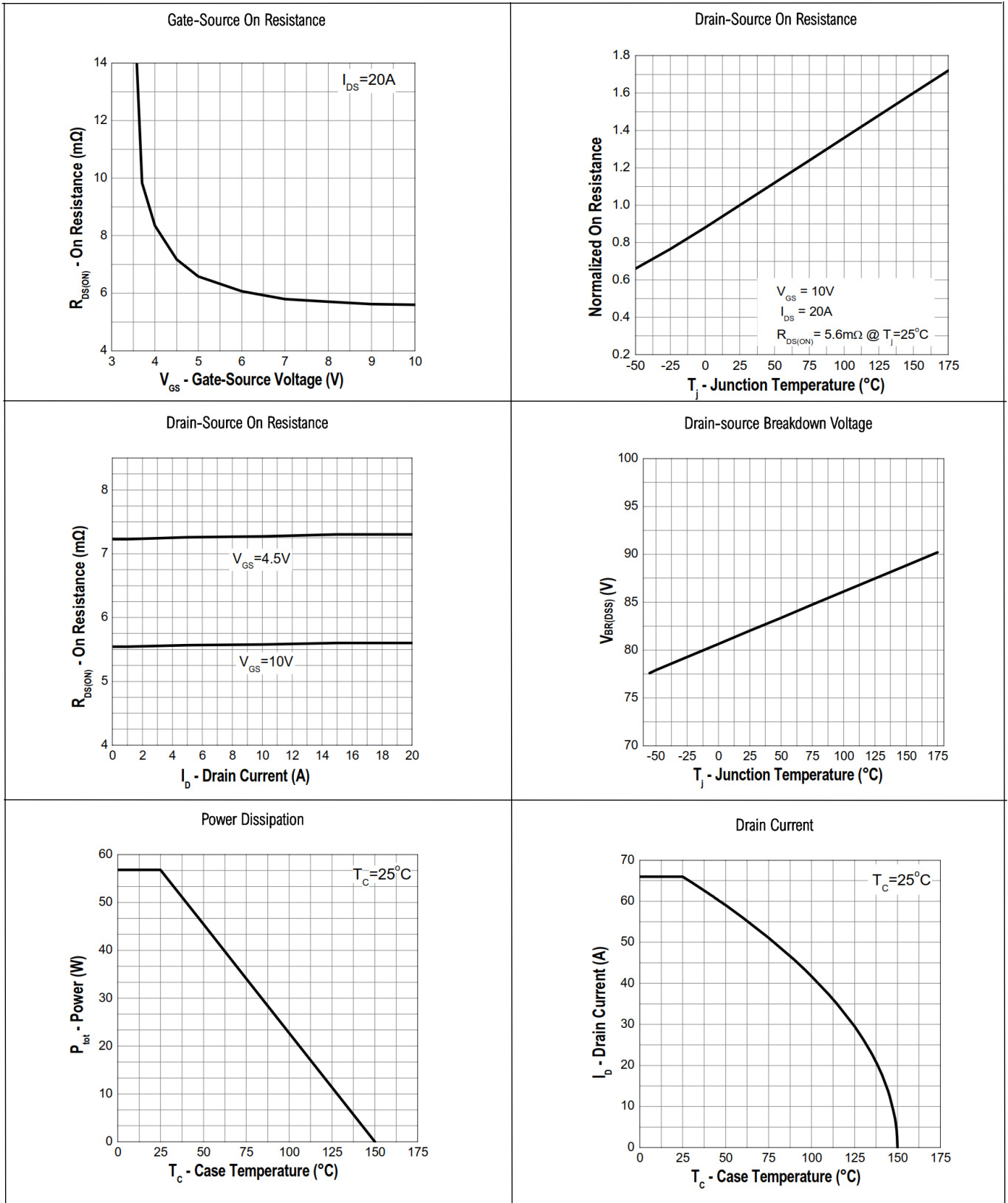

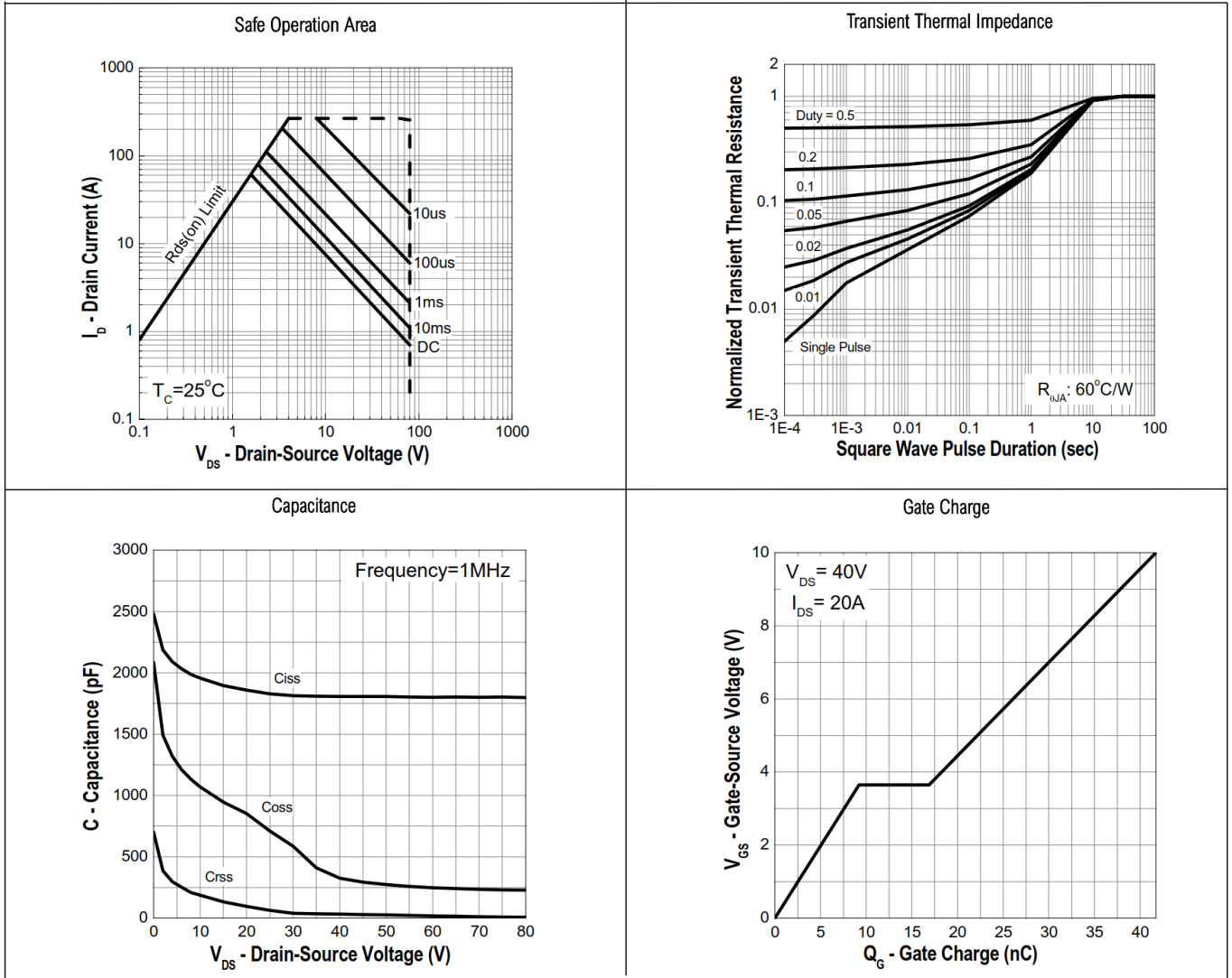

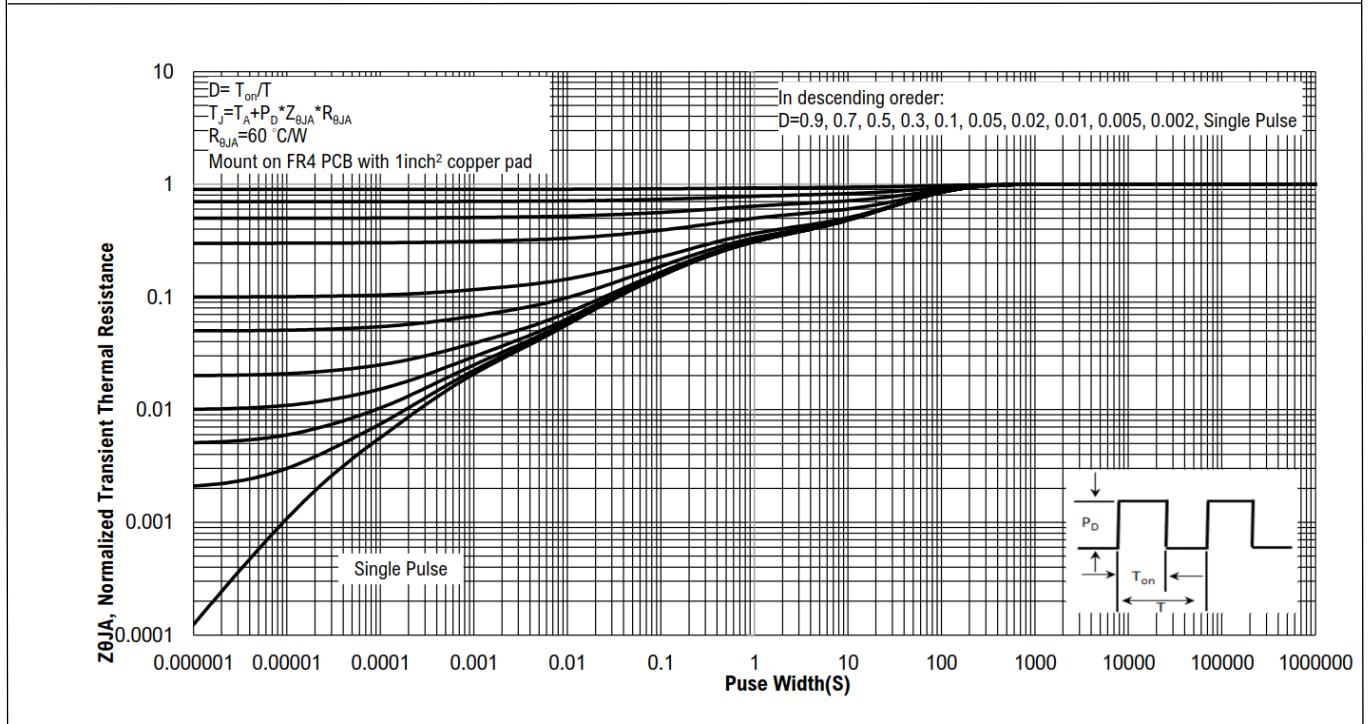
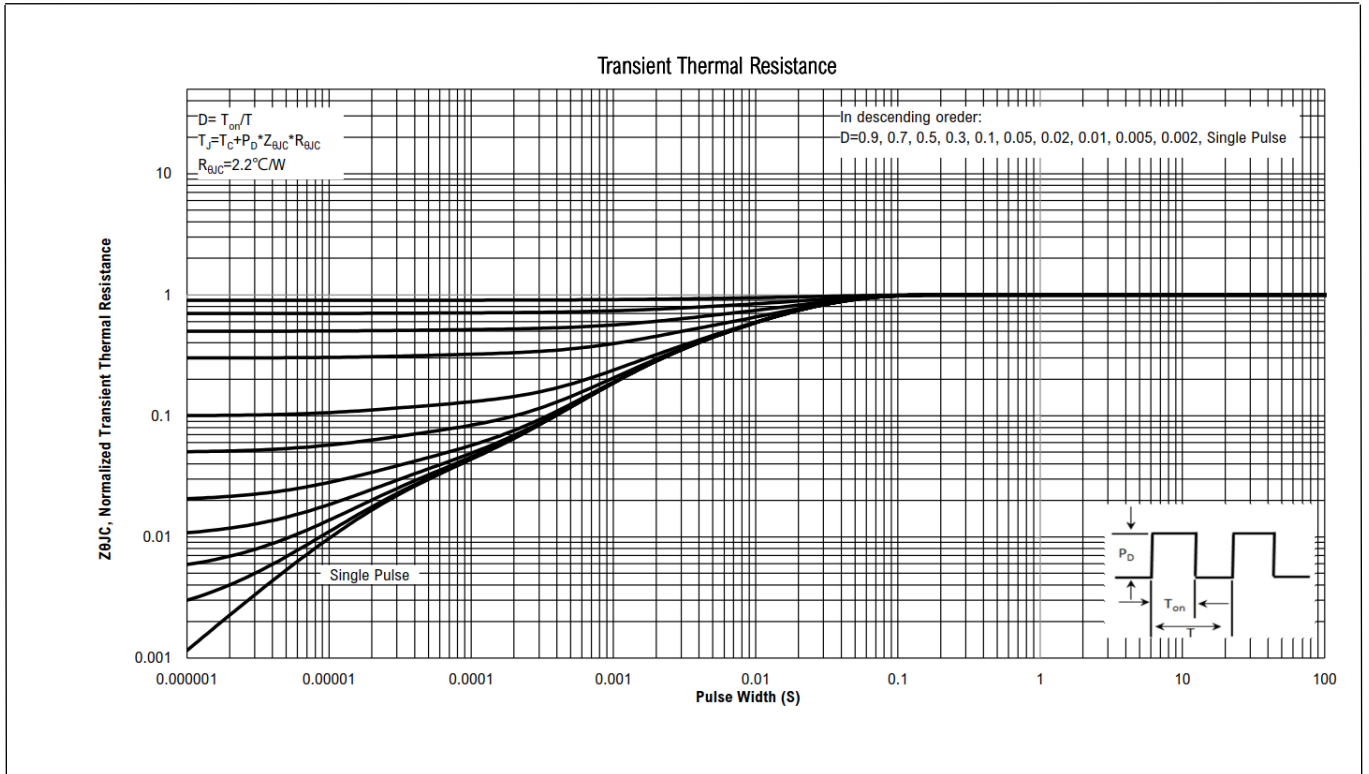

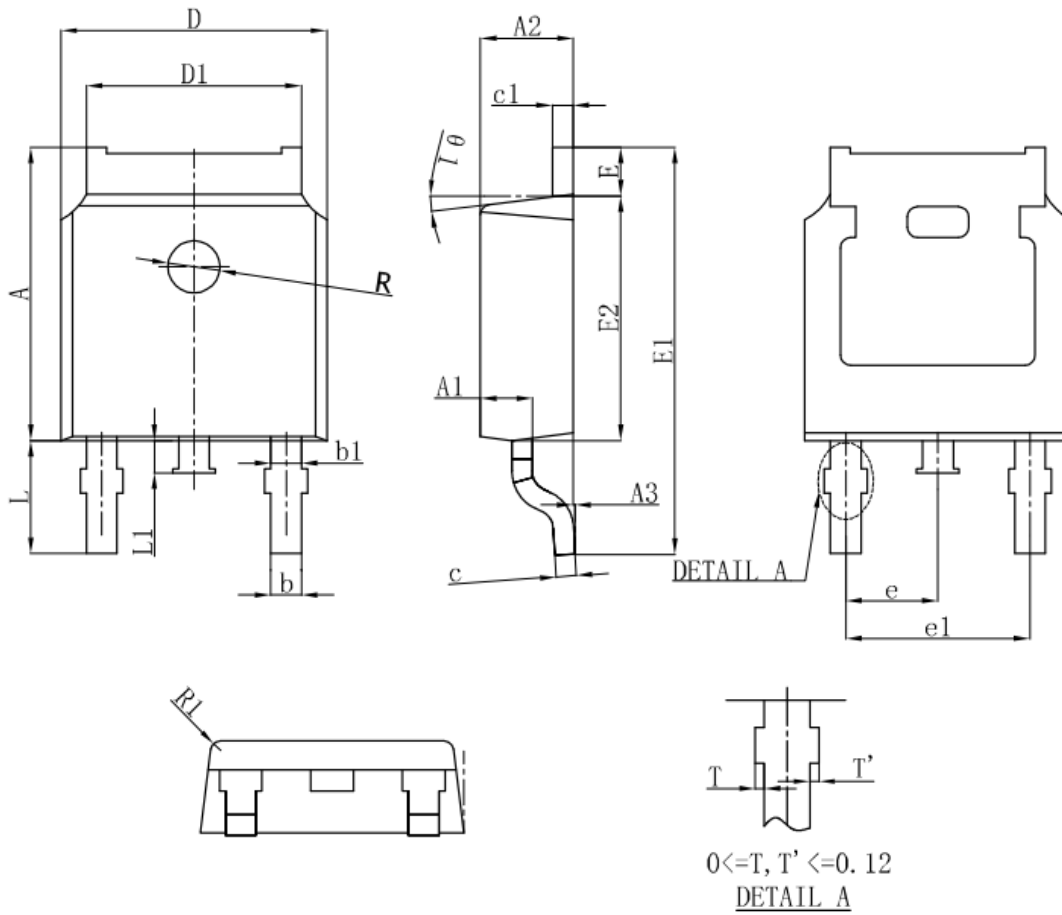
Package Outline Dimensions

SYMBOL	MILLIMETER		
	MIN	NOM	MAX
A	7.050	7.100	7.150
A1	0.960	1.010	1.060
A2	2.250	2.300	2.350
A3	0.000	0.050	0.100
b	0.760REF.		
b1	1.000REF.		
c	0.508REF.		
c1	0.508REF.		
D	6.550	6.600	6.650
D1	5.220	5.320	5.420
E	0.950	1.000	1.050
E1	9.700	9.900	10.100
E2	6.050	6.100	6.150
e	2.286BSC		
e1	4.572REF.		
L	2.650	2.800	2.950
L1	0.700	0.800	0.900
θ	7° REF.		
R	0.250REF.		

Legal Disclaimer

The information given in this document shall be for illustrative purposes only and shall in no event be regarded as a guarantee of conditions or characteristics. Existar Technologies reserves the right to change any information herein. With respect to any examples, hints or any typical values stated herein and/or any information regarding the application of the product, Existar Technologies or its affiliates hereby make no representation or warranty of any kind, expressed or implied, as to any information provided hereunder, including without limitation as to the accuracy, completeness or non-infringement of intellectual property rights of any third party, and they assume no liability for the consequences of use of such information. In addition, any information given in this document is subject to customer's compliance with its obligations stated herein and any applicable legal requirements, norms and standards concerning customer's products and any use of the product of Existar Technologies in customer's applications. The information contained herein is exclusively intended for technically trained staff. No license is granted by implication under any patent right, copyright, mask work right, or other intellectual property right. It is customer's sole responsibility to evaluate the suitability of the product for the intended application and the completeness of the product information given herein with respect to such application. In no event shall Existar Technologies or its affiliates be liable to any party for any direct, indirect, special, punitive, incidental or consequential damages of any nature whatsoever, including but not limited to loss of profits and loss of goodwill, whether or not such damages are based on tort or negligence, warranty, breach of contract or any other legal theory.