

广东星坤科技股份有限公司
日期
文件工程章

MARK	DESCRIPTION	DATE	REVISED	APPROVED	UNSPECIFIED TOLERANCES
Δ*					ANGLAR ±5°
Δx					L ≤ 4 ±0.2
Δx					4 < L ≤ 16 ±0.3
					16 < L ≤ 63 ±0.4
					L > 63 ±0.5
					REVISIONS
					www.helloxkb.com www.helloxkb.cn www.xk-dg.cn



DSND		SCALE: N/A	MODEL TYPE:
DWN		VIEW:	PART NO.: X1304WWS-52X-LPV10
CHKD		UNIT: mm/in	DWG NO.:
APPD		SIZE: A4	X-X1304WWS-52X-LPV10
		WEIGHT	SHEET
			1/1
			REVISION
			A0

XKB INDUSTRIAL PRECISION CO., LIMITED

NOTES 注释:

1. MATERIAL材料:

HOUSING外壳: THERMOPLASTIC, HIGH TEMP.,
UL94V-0;BLACK COLOR

CONTACTS触点: COPPER ALLOY.

PEGS螺钉: COPPER ALLOY.

2. FINISH饰面:

CONTACT触点:SELECTEIVE GOLD PLATING ON CONTACT AREA.
100μ"MIN. MATTE TIN PLATING ON SOLDER TAILS,
50μ" MIN. NICKEL UNDERPLATING OVERALL.

PEGS螺钉: 120u" MIN. MATTE-TIN OVER 50u" MIN. NICKEL.

X1304 W V S - 52 X - LP V10

① ② ③ ④ ⑤ ⑥ ⑦ ⑧

① Series Number

② Terminal form: W-Wafer

③ Welding Board Angle : V-Stright Angle 180°

④ Welding Way:S-SMT

⑤ No.of Pins: 52 PIN

⑥ HEIGHT: A 4.0mm;B 5.2mm;C 5.6mm;D 6.8mm;
E 7.0mm;F 8.0mm;G 9.0mm;H 9.9mm

⑦ Plastic material: LP-LCP UL94V-0

⑧ Contact Plating:V01-Gold Flash
V10-Gold 10 u"
V30-Gold 30 u"

广东星坤科技股份有限公司

Δ	日期
Δ	
Δ	
MARK	文件工程章

MARK	DESCRIPTION	DATE	REVISED	APPROVED	ANGLAR	±5°
					L ≤ 4	±0.2
					4 < L ≤ 16	±0.3
					16 < L ≤ 63	±0.4
					L > 63	±0.5
REVISIONS					UNSPECIFIED TOLERANCES	

DSND		SCALE: N/A	MODEL TYPE:
DWN		VIEW:	PART NO.: X1304WVS-52X-LPV10
CHKD		UNIT: mm/in	DWG NO.: X-X1304WVS-52X-LPV10
APPD		SIZE: A4	
XKB INDUSTRIAL PRECISION CO.,LIMITED			WEIGHT
			SHEET 1/1
			REVISION A0



COMPONENT KEEP OUT AREA FOR
CARD HOLD DOWN SOLUTION

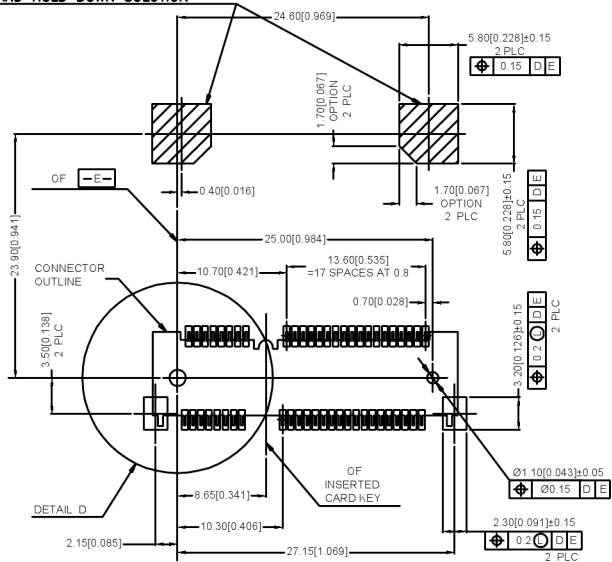

—D— IS THE TOP SURFACE OF PCB.
RECOMMENDED P.C. BOARD PATTERN LAYOUT
FOR HALF CARD CONNECTOR
(TOP VIEW)

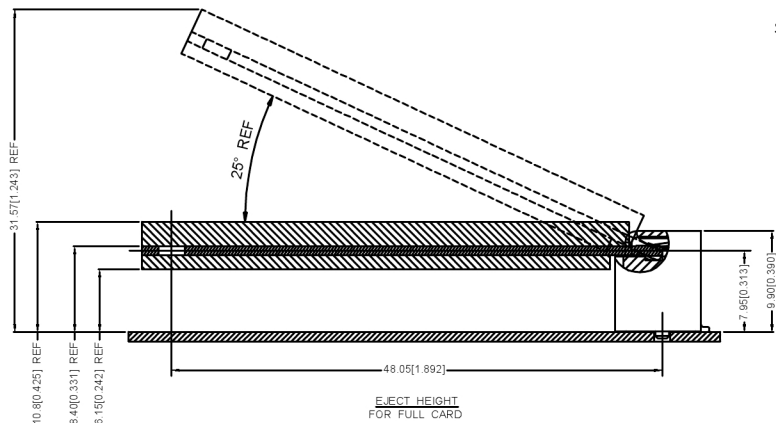

EJECT HEIGHT
FOR FULL CARD

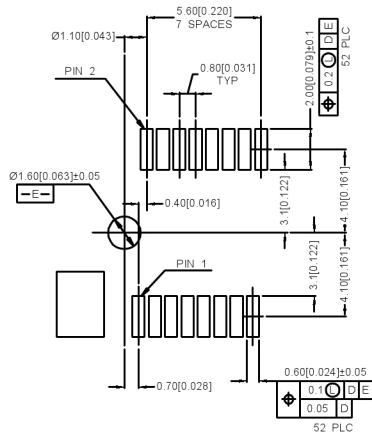

DETAIL D
SCALE 2:1

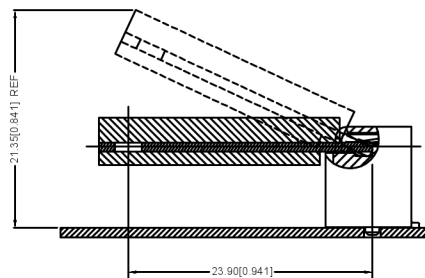

EJECT HEIGHT
FOR HALF CARD

COMPONENT KEEP OUT AREA FOR
CARD HOLD DOWN SOLUTION

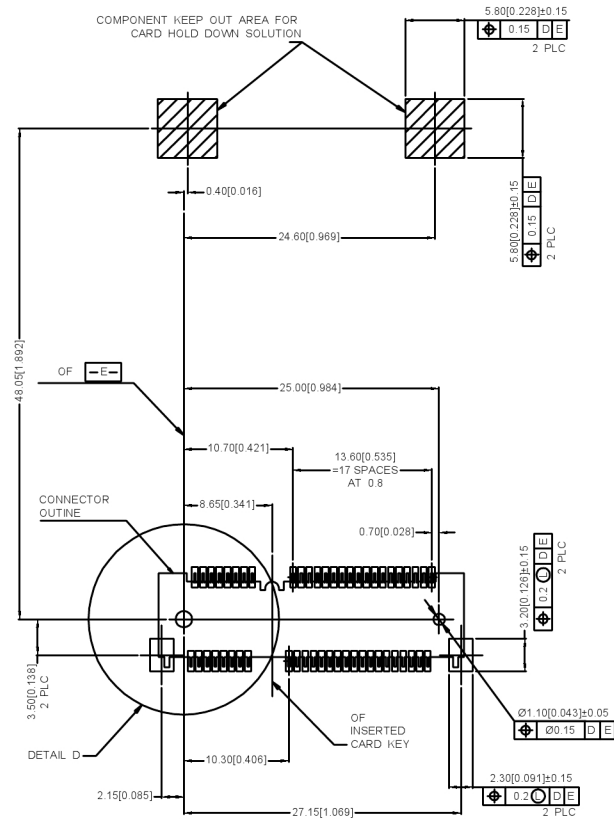

—D— IS THE TOP SURFACE OF PCB.
RECOMMENDED P.C. BOARD PATTERN LAYOUT
FOR HALF CARD CONNECTOR
(TOP VIEW)

广东星坤科技股份有限公司

Δ建	日期
Δ改	日期
ΔX	
MARK	DESCRIPTION

						ANGLAR	±5°
						L ≤ 4	±0.2
						4 < L ≤ 16	±0.3
						16 < L ≤ 63	±0.4
						L > 63	±0.5
						UNSPECIFIED TOLERANCES	



DSND		SCALE: N/A	MODEL TYPE:
DWN		VIEW:	PART NO.: X1304WVS-52X-LPV10
CHKD		UNIT: mm/in	DWG NO.:
APPD		SIZE: A4	X-X1304WVS-52X-LPV10
		WEIGHT	SHEET
			REVISION

XKB INDUSTRIAL PRECISION CO., LIMITED

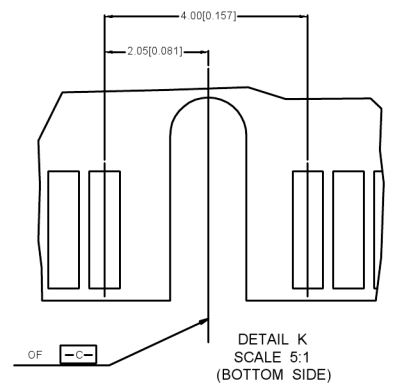
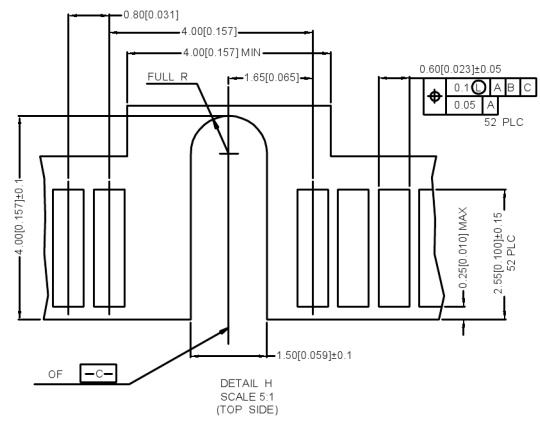
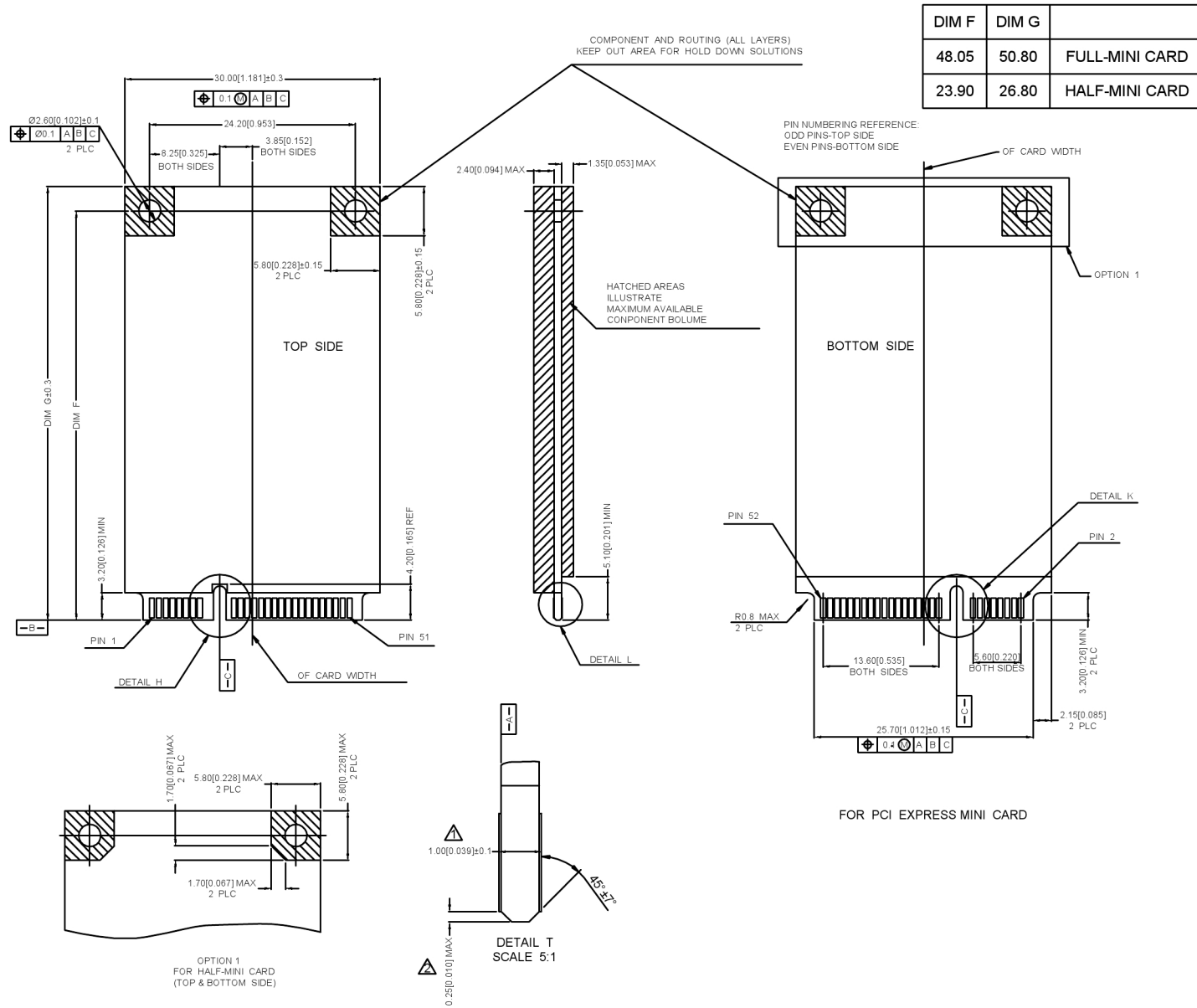

NOTES 注释:

- △ CARD THICKNESS APPLIES ACROSS TABS AND INCLUDES PLATING AND/OR METALLIZATION.
卡片厚度适用于所有接线片，包括电镀和/或金属化。
- △ EDGE BEVEL MUST BE PRESENT AND FREE OF CUTTING CONTACT MATERIALS BURRS FROM AND PCB
边缘斜面必须均匀且无切割接触材料毛刺和PCB

广东星坤科技股份有限公司

Δ 作	日期
Δ 文	日期
Δ 改	日期
MARK	DESCRIPTION
文件	工程章

					ANGLAR	±5°
					L ≤ 4	±0.2
					4 < L ≤ 16	±0.3
					16 < L ≤ 63	±0.4
					L > 63	±0.5
					UNSPECIFIED TOLERANCES	



DSND		SCALE: N/A	MODEL TYPE:
DWN		VIEW:	PART NO.: X1304WWS-52X-LPV10
CHKD		UNIT: mm/in	DWG NO.:
APPD		SIZE: A4	X-X1304WWS-52X-LPV10
			WEIGHT
			SHEET
			REVISION
			1/1
			A0

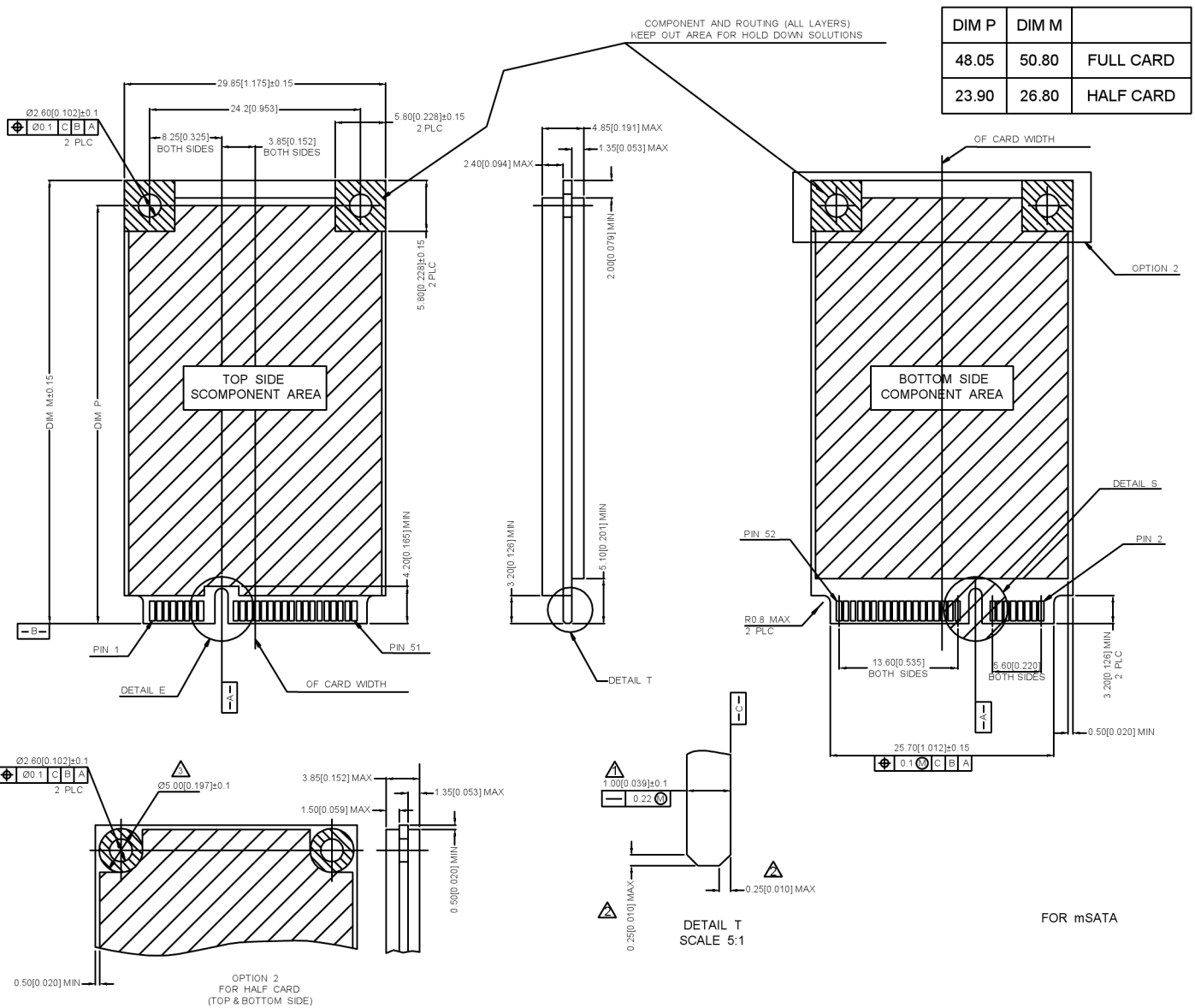

DIM P	DIM M	
48.05	50.80	FULL CARD
23.90	26.80	HALF CARD

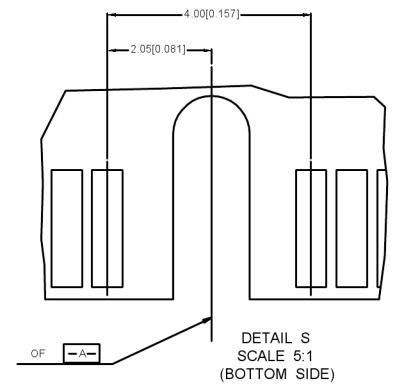
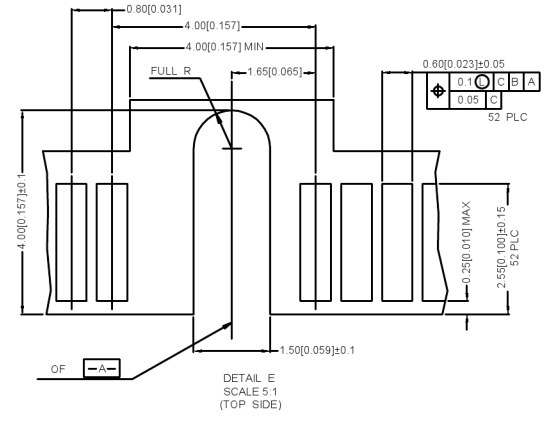

- NOTES 注释:
- △ CARD THICKNESS APPLIES ACROSS TABS AND INCLUDES PLATING AND/OR METALLIZATION.
卡片厚度适用于所有接线片，包括电镀和/或金属化。
 - △ EDGE BEVEL MUST BE IPRESENT AND FREE OF CUTTING CONTACT MATERIALS BURRS FROM AND PCB
边缘斜面必须均匀且无切割接触材料毛刺和PCB
 - △ COMPONENT AND ROUTING (TOP/BOTTOM LAYER) KEEP OUT AREA FOR HOLD DOWN SOLUTIONS.
元件和布线(顶层/底层)为压紧解决方案留出区域

广东星坤科技股份有限公司

姓名	日期
数量	日期
MARK	DESCRIPTION

文件工程章

DATE	REVISED	APPROVED	UNSPECIFIED TOLERANCES
ANGLAR	±5°		
L ≤ 4	±0.2		
4 < L ≤ 16	±0.3		
16 < L ≤ 63	±0.4		
L > 63	±0.5		
REVISIONS			
www.helloxkb.com www.helloxkb.com www.xk-dg.cn			



DSND	SCALE: N/A	MODEL TYPE:
DWN	VIEW:	PART NO.: X1304WVS-52X-LPV10
CHKD	UNIT: mm/in	DWG NO.:
APPD	SIZE: A4	X-X1304WVS-52X-LPV10
XKB INDUSTRIAL PRECISION CO., LIMITED		WEIGHT SHEET REVISION
		1/1 A0