

Transformer Driver for Isolated Power Supplies

Features

- Push-pull driver for transformers
- Operates with 2.7-V to 5.5-V supply
- High output drive: 1A at 5V supply
- Low R_{ON} 0.25Ω at 4.5V
- Spread spectrum clocking (SSC)
- Ultra-low EMI
- Precision internal oscillator
- Slew-rate control
- 1.7A Current-limit
- Low shutdown current: <math><1 \mu A</math>
- Thermal shutdown protection
- Wide temperature range: $-45^{\circ}C$ to $125^{\circ}C$
- Small package: SOT23-5

Applications

- Isolated Interface Power Supply for CAN, RS-485, RS422, RS-232, SPI, I2C
- Low-Power LAN
- Isolated USB Supplies
- Industrial Automation

General Description

The COS6501 is a low-EMI push-pull transformer driver, specifically designed for small form factor, isolated power supplies in isolated interface applications. The device drives a low-profile, center-tapped transformer primary from a 2.7-V or 5-V DC power supply. The secondary can be wound to provide any isolated voltage based on transformer turns ratio.

The COS6501 consists of an oscillator followed by a gate drive circuit that provides the complementary output signals to drive the ground referenced N-channel power switches. The internal logic ensures break-before-make action between the two switches. The internal protection features under-voltage lockout, thermal shutdown and output current limiting. Low noise and low-EMI are achieved by slew rate control of the output switch voltage and through Spread Spectrum Clocking (SSC).

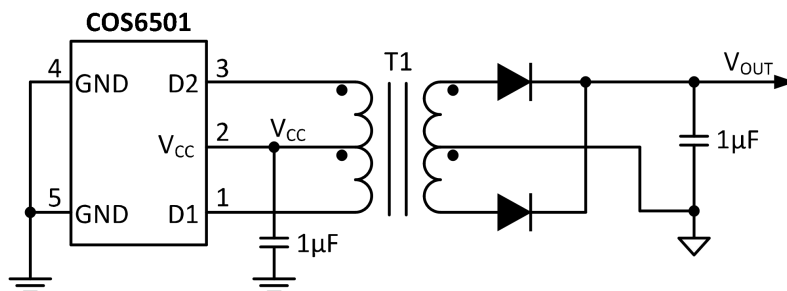

Typical Application

1. Pin Configuration and Functions

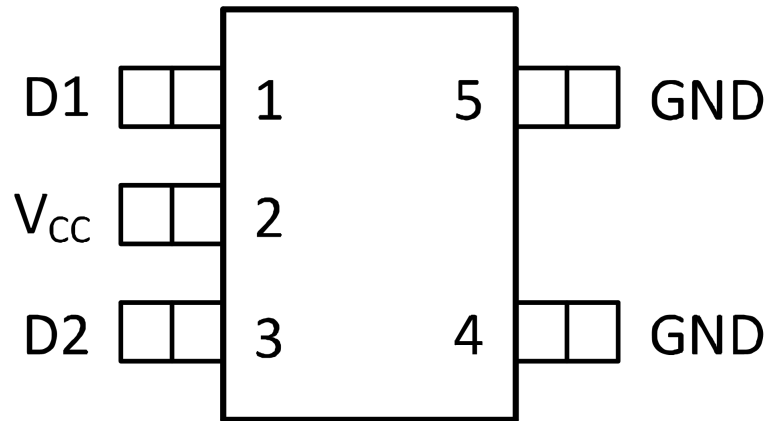

Figure 1 Pin Diagram

Pin Description

PIN			Description
No.	Name	Type	
1	D1	Open Drain	Open drain output 1. Connect this pin to one end of the transformer primary side.
2	VDD	Power	Supply voltage input. Connect this pin to the center-tap of the transformer primary side. Buffer this voltage with a 1μF to 10μF ceramic capacitor.
3	D2	Open Drain	Open drain output 2. Connect this pin to one end of the transformer primary side.
4,5	GND	Power	Device ground. Connect this pin to the board ground

2. Packaging and Ordering Information

Model	Package	Order Number	Package Option	Marking Information
COS6501	SOT23-5	COS6501	Tape and Reel, 3000	C6501

3. Product Specification

3.1 Absolute Maximum Ratings ⁽¹⁾

Parameter	Min	Max	Unit
DC supply voltage, V_{CC}	-0.3	6	V
Output switch voltage, V_{D1} , V_{D2}		18	V
Peak output switch current, I_{D1PK} , I_{D2PK}		1.7	A
Operating junction temperature	-55	+150	°C
Storage temperature	-65	+150	°C

(1) Stresses exceeding the absolute maximum ratings may damage the device. The device may not function or be operable above the recommended operating conditions and stressing the parts to these levels is not recommended. In addition, extended exposure to stresses above the recom

3.2 ESD Ratings

Parameter	Rating	Unit
Electrostatic Discharge, V_{ESD}	Human body mode (HBM)	± 8000
	Charge device model (CDM)	± 1000
		V

3.3 Thermal Data

Parameter	Rating	Unit
Package Thermal Resistance, $R_{\theta JA}$ (Junction-to-ambient)	190 (SOT23-5)	°C/W

3.4 Recommended Operating Conditions

Parameter	Min.	Typ.	Max.	Unit
DC Supply voltage, V_{CC}	2.7		5.5	V
D1 and D2 output switch current - Primary-side			1	A
Operating ambient temperature	-40		+125	°C

3.5 Electrical Characteristics

(All typical values are at $V_{CC}=5V$, $T_A=+25^{\circ}C$, unless otherwise noted)

Parameter	Symbol	Conditions	Min.	Typ.	Max.	Unit
Voltage Supply						
Average Supply Current	I_{CC}	no load		0.65	1.0	mA
Positive-going UVLO threshold	UVLO+			2.6		V
Positive-going UVLO threshold	UVLO-			2.4		V
UVLO Threshold Hysteresis	H_{UVLO}			0.2		V
CLK						
D1, D2 Switching Frequency	f_{SW}		360	420	520	kHz
Output Stage						
Switch-on Resistance	R_{ON}	$V_{CC} = 4.5V, I_{D1}, I_{D2} = 1 A$		0.16		Ω
		$V_{CC} = 2.8V, I_{D1}, I_{D2} = 1 A$		0.19		
Average ON time mismatch between D1 and D2	DMM			0		%
Voltage Slew Rate on D1 and D2	V_{SR}	$R_L = 50\Omega$ to VCC		85		V/ μ s
Current Slew Rate on D1 and D2	I_{SR}	$R_L = 5\Omega$ through transformer		40		A/ μ s
Current Clamp Limit	I_{LIM}	$2.7V < V_{CC} < 5.5V$	1.4	1.7	2.2	A
Break-Before-Make Time	t_{BBM}	$R_L = 50\Omega$ to VCC		50		ns
Thermal Shut Down						
Shutdown Temperature	T_{SD}		135	150	166	$^{\circ}C$
Thermal Hysteresis	T_{HYS}			17		$^{\circ}C$

4. Application Information

4.1 Overview

The COS6501 is a low-EMI push-pull transformer driver, specifically designed for small form factor, isolated power supplies in isolated interface applications. The device drives a low-profile, center-tapped transformer primary from a 2.7-V or 5-V DC power supply. The secondary can be wound to provide any isolated voltage based on transformer turns ratio.

The COS6501 consists of an oscillator followed by a gate drive circuit that provides the complementary output signals to drive the ground referenced N-channel power switches (Figure 2). The internal logic ensures break-before-make action between the two switches (Figure 3). The internal protection features under-voltage lockout, thermal shutdown and output current limiting.

Radiated emissions is an important concern in high current switching power supplies. COS6501 addresses this by modulating its internal clock in such a way that the emitting energy is spread over multiple frequency bins. This Spread Spectrum clocking feature greatly improves the emissions performance of the entire power supply block and hence relieves the system designer from one major concern in isolated power supply design.

4.2 Functional Block Diagram

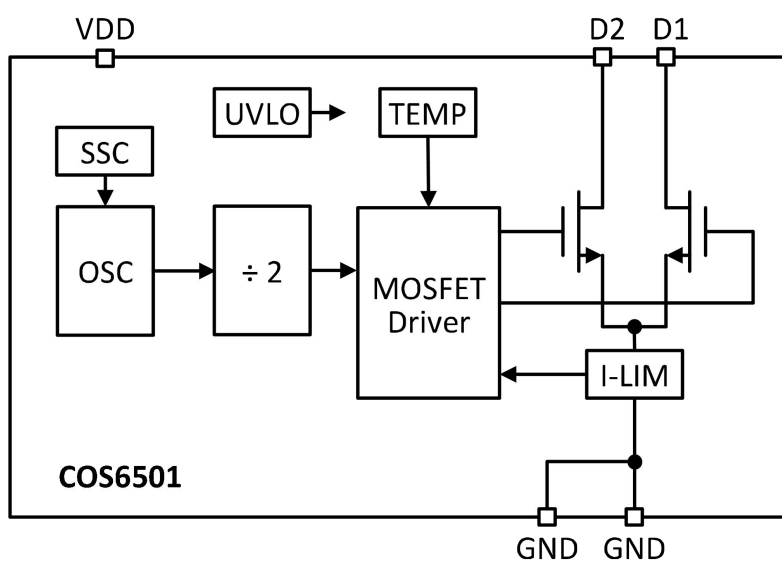

Figure 2. Functional Block Diagram

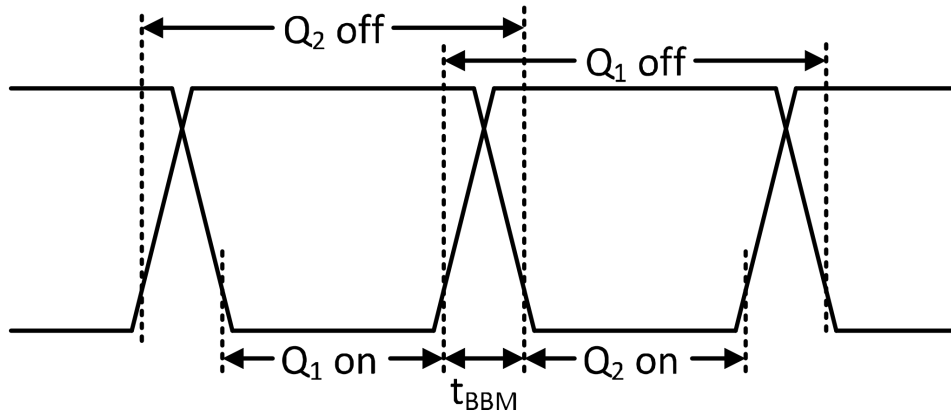

Figure 3. Output Timing with Break-Before-Make Action

4.3 Typical Application Circuits

4.3.1 Unregulated Output versus Regulated Output

The output voltage of the unregulated converter (Figure 4) drops significantly over a wide range in load current. Therefore, in order to provide a stable, load independent supply while maintaining maximum possible efficiency, the implementation of a low dropout regulator (LDO) is strongly advised (Figure 5).

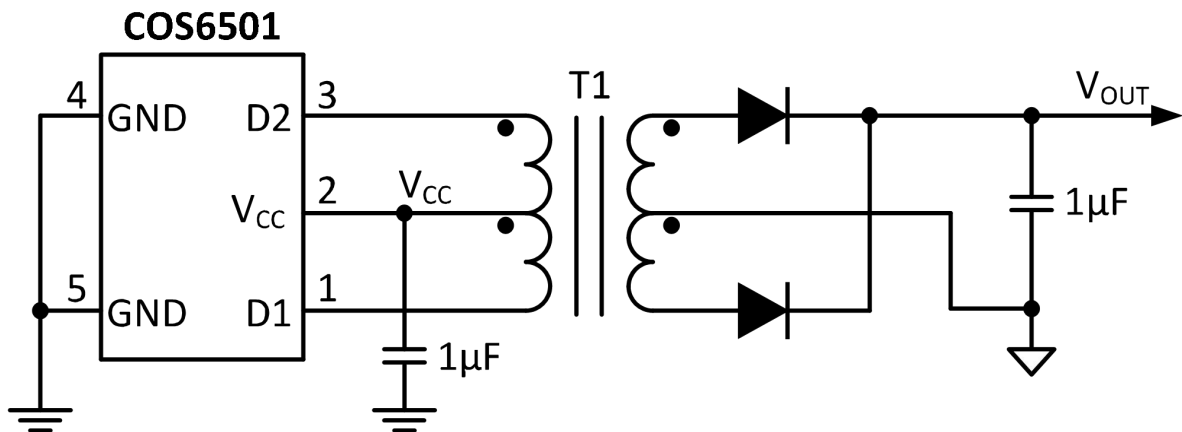

Figure 4. Unregulated Output for Low-Current Loads

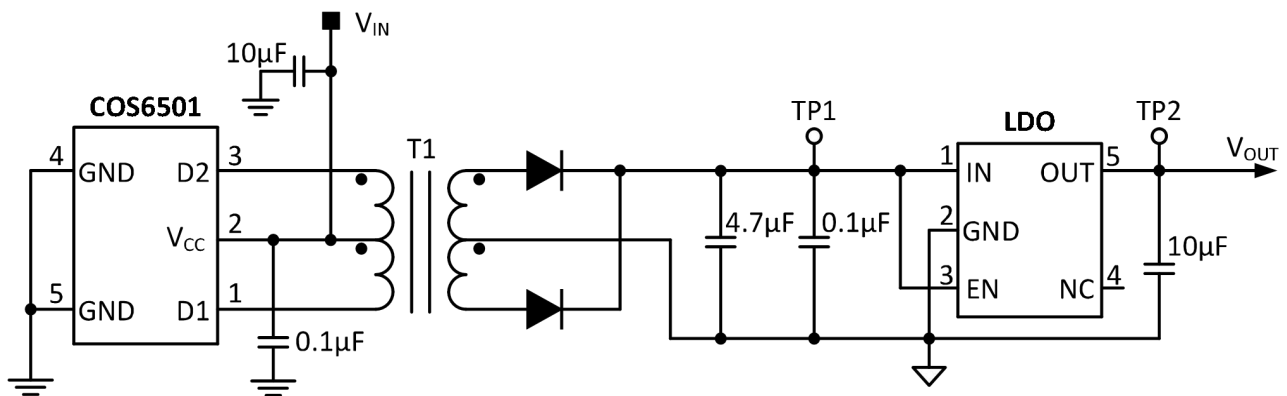

Figure 5. Regulated Output for Stable Supplies and High Current Loads

4.3.2 Higher Output Voltage Designs

The device can drive push-pull converters that provide high output voltages of up to 30 V, or bipolar outputs of up to ± 15 V. Using commercially available center-tapped transformers, with their rather low turns ratios of 0.8 to 5, requires different rectifier topologies to achieve high output voltages. Figure 6 and Figure 7 show some of these topologies together with their respective open-circuit output voltages.

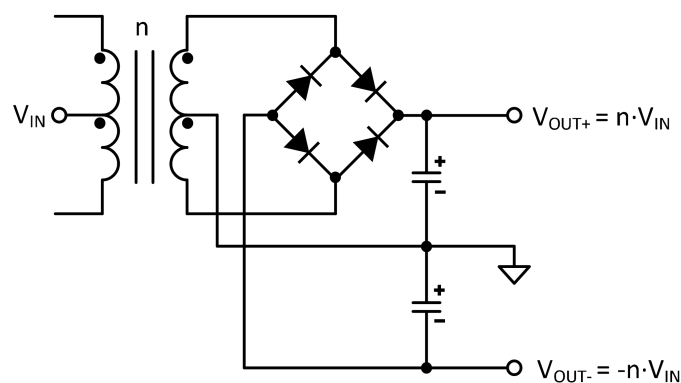

Figure 6. Bridge Rectifier with Center-Tapped Secondary Enables Bipolar Outputs

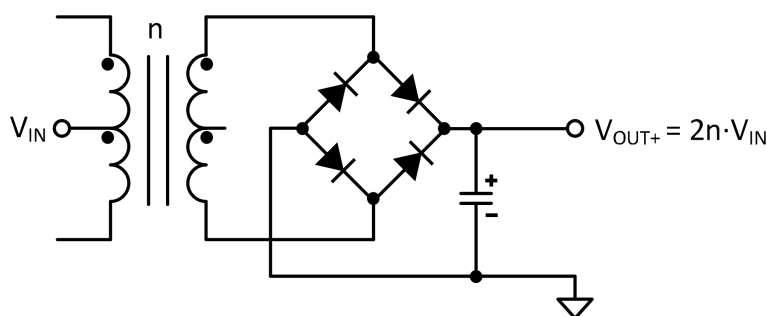

Figure 7. Bridge Rectifier without Center-Tapped Secondary Performs Voltage Doubling

4.4 Component Selection

4.4.1 Diode Selection

A rectifier diode should always possess low-forward voltage to provide as much voltage to the converter output as possible. When used in high-frequency switching applications, the diode must also possess a short recovery time. Schottky diodes meet both requirements and are therefore strongly recommended in push-pull converter designs.

4.4.2 Capacitor Selection

The input bulk capacitor at the center-tap of the primary supports large currents into the primary during the fast switching transients. For minimum ripple make this capacitor $1\mu\text{F}$ to $10\mu\text{F}$. In a 2-layer PCB design with a dedicated ground plane, place this capacitor close to the primary center-tap to minimize trace inductance.

The bulk capacitor at the rectifier output smooths the output voltage. Make this capacitor $1\mu\text{F}$ to $10\mu\text{F}$. The small capacitor at the regulator input is not necessarily required. However, good analog design practice suggests, using a small value of 47 nF to 100 nF improves the regulator's transient response and noise rejection.

The LDO output capacitor buffers the regulated output for the subsequent isolator and transceiver circuitry. The choice of output capacitor depends on the LDO stability requirements specified in the data sheet. However, in most cases, a low-ESR ceramic capacitor in the range of $4.7\mu\text{F}$ to $10\mu\text{F}$ will satisfy these requirements.

4.4.3 Transformer Selection

The factors that must be considered before making the transformer decision include: isolation voltage, transformer wattage, V-t product and turns ratio.

4.4.3.1 V-t Product Calculation

The volt-seconds (V-t) product is an important parameter as it determines the core magnetization during each switching cycle. If the V-t products of both phases are not identical, an imbalance in flux density swing results with an offset from the origin of the B-H curve (Figure 8). If balance is not restored, the offset increases with each following cycle and the transformer slowly creeps toward the saturation region.

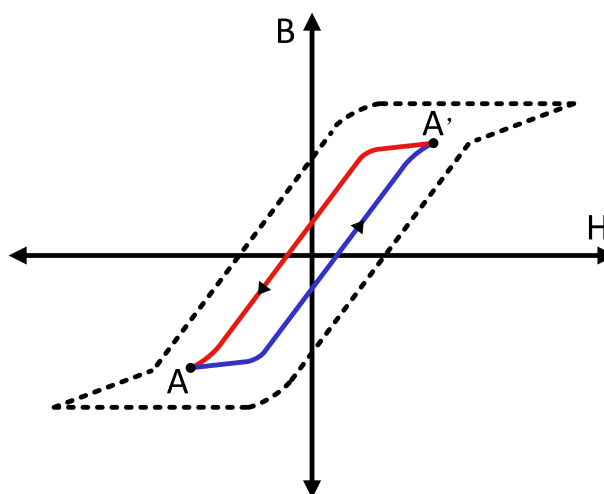

Figure 8. An Ideal Magnetizing Curve for a Push-Pull Converter

To prevent a transformer from saturation its V-t product must be greater than the maximum V-t product applied by the device. The maximum voltage delivered by the device is the nominal converter input plus 10%. The maximum time this voltage is applied to the primary is half the period of the lowest frequency at the specified input voltage. Therefore, the transformer's minimum V-t product is determined through:

$$Vt_{\min} \geq V_{IN-\max} \times \frac{T_{\max}}{2} = \frac{V_{IN-\max}}{2 \times f_{\min}} \quad (1)$$

Taking an example of f_{\min} as 360kHz for COS6501 with a 5 V supply, Equation 1 yields the minimum V-t products of:

$$V_{t_{\min}} \geq \frac{5.5V}{2 \times 360 \text{ kHz}} = 7.6 \text{ V}\mu\text{s} \quad (2)$$

4.4.3.2 Turns Ratio Estimate

The minimum transformation ratio is expressed through the ratio of minimum secondary to minimum primary voltage multiplied by a correction factor that takes the transformer's typical efficiency of 97% into account:

$$N_{\min} = 1.03 \times V_{S-\min} / V_{P-\min} \quad (3)$$

Then calculating the available minimum primary voltage, $V_{P-\min}$, involves subtracting the maximum possible drain-source voltage of the device, $V_{DS-\max}$, from the minimum converter input voltage $V_{IN-\min}$:

$$\begin{aligned} V_{P-\min} &= V_{IN-\min} - V_{DS-\max} \\ &= V_{IN-\min} - R_{DS-\max} \times I_{D-\max} \end{aligned} \quad (4)$$

$V_{S-\min}$ must be large enough to allow for a maximum voltage drop, $V_{F-\max}$, across the rectifier diode and still provide sufficient input voltage for the regulator to remain in regulation.

$$V_{S-\min} = V_{F-\max} + V_{DO-\max} + V_{O-\max} \quad (5)$$

Inserting Equation 4 and Equation 5 into Equation 3 provides the minimum turns ration with:

$$n_{\min} = 1.03 \times \frac{V_{F-\max} + V_{DO-\max} + V_{O-\max}}{V_{IN-\min} - R_{DS-\max} \times I_{D-\max}} \quad (6)$$

4.4.4 Power Supply Recommendations

The COS6501 are designed to operate from an input voltage supply range between 2.7 V and 5V nominal. This input supply must be regulated within $\pm 10\%$. If the input supply is located more than a few inches from the device, a 0.1 μF by-pass capacitor should be connected as close as possible to the device VCC pin and a 10 μF capacitor should be connected close to the transformer center-tap pin.

5. Package Information

5.1 SOT23-5 (Package Outline Dimensions)

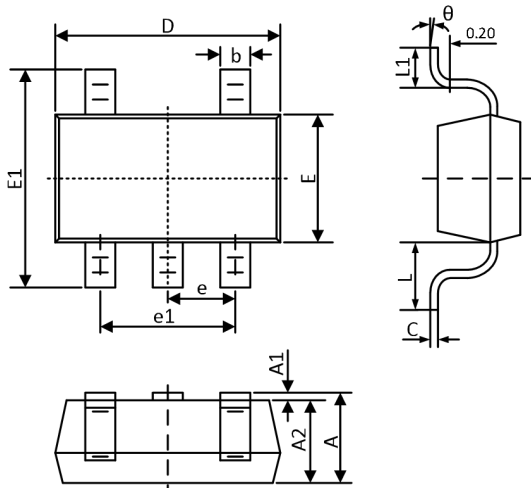

Symbol	Dimensions In Millimeters		Dimensions In Inches	
	MIN	MAX	MIN	MAX
A	1.050	1.250	0.041	0.049
A1	0.000	0.100	0.000	0.004
A2	1.050	1.150	0.041	0.045
b	0.300	0.400	0.012	0.016
c	0.100	0.200	0.004	0.008
D	2.820	3.020	0.111	0.119
E	1.500	1.700	0.059	0.067
E1	2.650	2.950	0.104	0.116
e	0.950TYP		0.037TYP	
e1	1.800	2.000	0.071	0.079
L	0.700REF		0.028REF	
L1	0.300	0.600	0.012	0.024
θ	0°	8°	0°	8°

Rev1.0

Copyright©2018 Cosine Nanoelectronics Inc. All rights reserved.

The information provided here is believed to be accurate and reliable. Cosine Nanoelectronics assumes no reliability for inaccuracies and omissions. Specifications described and contained here are subjected to change without notice on the purpose of improving the design and performance. All of this information described herein should not be implied or granted for any third party.