

广东星坤科技股份有限公司

DATE	日期
DESCRIPTION	文件工程章

MARK	DESCRIPTION	DATE	REVISED	APPROVED	UNSPECIFIED TOLERANCES
	REVISIONS				
					ANGLAR ±5°
					L ≤ 4 ±0.2
					4 < L ≤ 16 ±0.3
					16 < L ≤ 63 ±0.4
					L > 63 ±0.5



DSND	SCALE: N/A	MODEL TYPE:
DWN	VIEW:	PART NO.: X1304WVS-52A-LPV10
CHKD	UNIT: mm/in	DWG NO.: X-X1304WVS-52A-LPV10
APPD	SIZE: A4	WEIGHT
		SHEET 1/1
		REVISION A0

XKB INDUSTRIAL PRECISION CO., LIMITED

NOTES 注释:

1. MATERIAL 材料:

HOUSING 外壳: THERMOPLASTIC, HIGH TEMP.,
UL94V-0; BLACK COLOR

CONTACTS 触点: COPPER ALLOY.

PEGS 螺钉: COPPER ALLOY.

2. FINISH 饰面:

CONTACT 触点: SELECTEIVE GOLD PLATING ON CONTACT AREA.
100 μ " MIN. MATTE TIN PLATING ON SOLDER TAILS,
50 μ " MIN. NICKEL UNDERPLATING OVERALL.

PEGS 螺钉: 120u" MIN. MATTE-TIN OVER 50u" MIN. NICKEL.

X1304 W V S - 52 A - LP V10

- ① ② ③ ④ ⑤ ⑥ ⑦ ⑧

① Series Number

② Terminal form: W-Wafer

③ Welding Board Angle : V-Stright Angle 180°

④ Welding Way: S-SMT

⑤ No. of Pins: 52 PIN

⑥ HEIGHT: A 4.0mm; B 5.2mm; C 5.6mm; D 6.8mm;
E 7.0mm; F 8.0mm; G 9.0mm; H 9.9mm

⑦ Plastic material: LP-PCP UL94V-0



⑧ Contact Plating: V01-Gold Flash 1"u";
V10-Gold Flash 10"u";
V30-Gold Flash 30"u"

广东星坤科技股份有限公司

DATE	日期
REVISIONS	文件工程章

www.helloxkb.com www.helloxkb.cn www.xk-dg.cn

MARK	DESCRIPTION	DATE	REVISED	APPROVED	ANGLAR	±5°
					L ≤ 4	±0.2
					4 < L ≤ 16	±0.3
					16 < L ≤ 63	±0.4
					L > 63	±0.5
					UNSPECIFIED TOLERANCES	

	DSND	SCALE: N/A	MODEL TYPE:
	DWN	VIEW: 	PART NO.: X1304WWS-52A-LPV10
	CHKD	UNIT: mm/in	DWG NO.: X-X1304WWS-52A-LPV10
	APPD	SIZE: A4	WEIGHT SHEET REVISION
XKB INDUSTRIAL PRECISION CO., LIMITED			1/1 A0

COMPONENT KEEP OUT AREA FOR
CARD HOLD DOWN SOLUTION

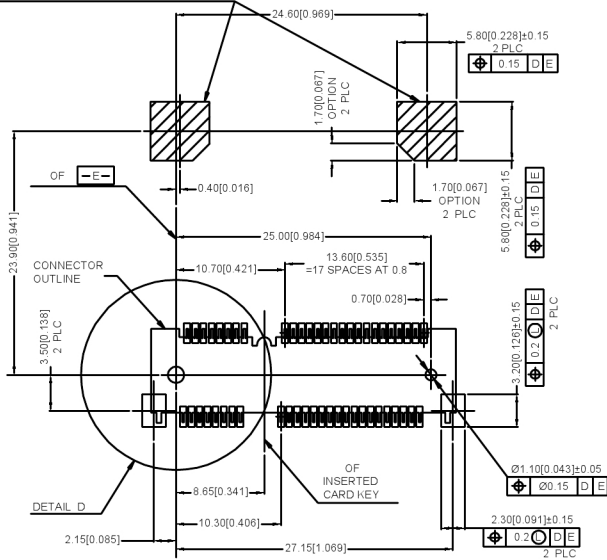

—D— IS THE TOP SURFACE OF PCB.
RECOMMENDED P.C. BOARD PATTERN LAYOUT
FOR HALF CARD CONNECTOR
(TOP VIEW)

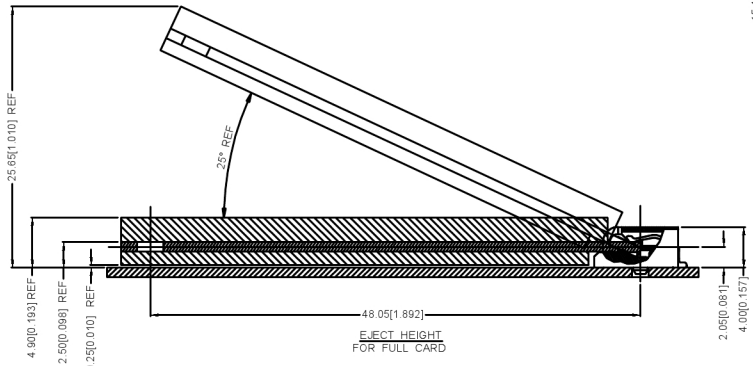

EJECT HEIGHT
FOR FULL CARD

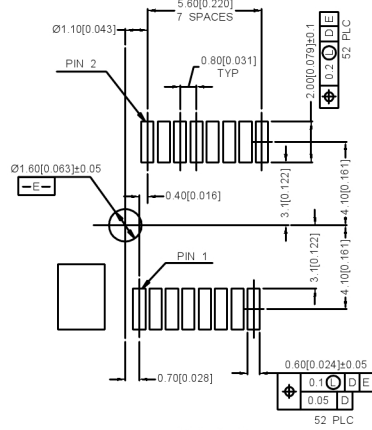

DETAIL D
SCALE 2:1

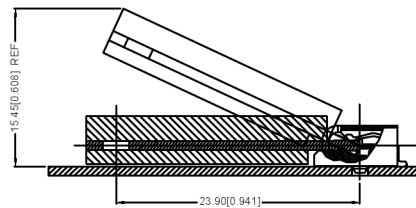

EJECT HEIGHT
FOR HALF CARD

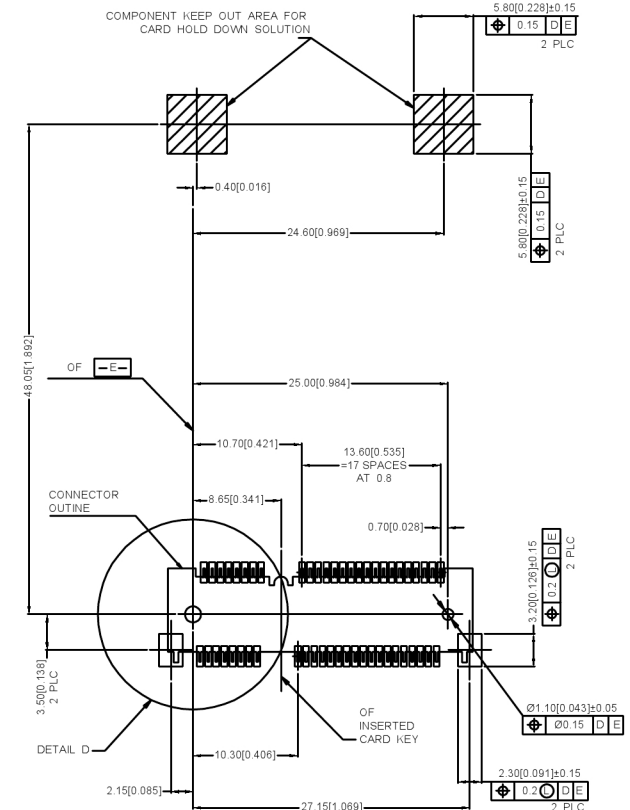

—D— IS THE TOP SURFACE OF PCB.
RECOMMENDED P.C. BOARD PATTERN LAYOUT
FOR HALF CARD CONNECTOR
(TOP VIEW)

广东星坤科技股份有限公司

Δ建	日期
Δ改	日期
ΔX	

文件工程单

MARK	DESCRIPTION	DATE	REVISED	APPROVED	UNSPECIFIED TOLERANCES
	REVISIONS				

ANGLAR	±5°
L ≤ 4	±0.2
4 < L ≤ 16	±0.3
16 < L ≤ 63	±0.4
L > 63	±0.5



DSND		SCALE: N/A	MODEL TYPE:
DWN		VIEW:	PART NO.:
CHKD		UNIT: mm/in	X1304WWS-52A-LPV10
APPD		SIZE: A4	DWG NO.:
			X-X1304WWS-52A-LPV10
			WEIGHT
			SHEET
			REVISION
			1/1
			A0

XKB INDUSTRIAL PRECISION CO., LIMITED

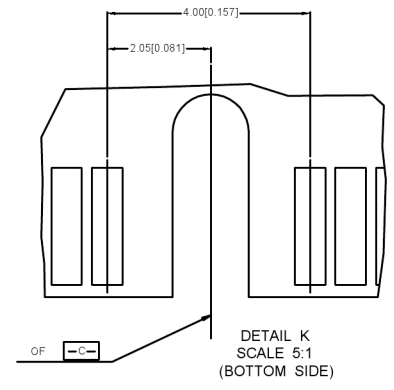
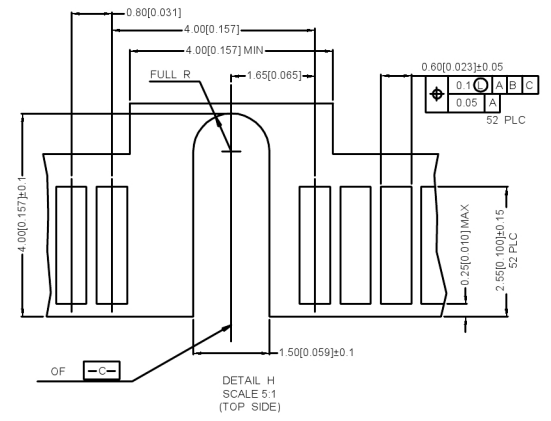
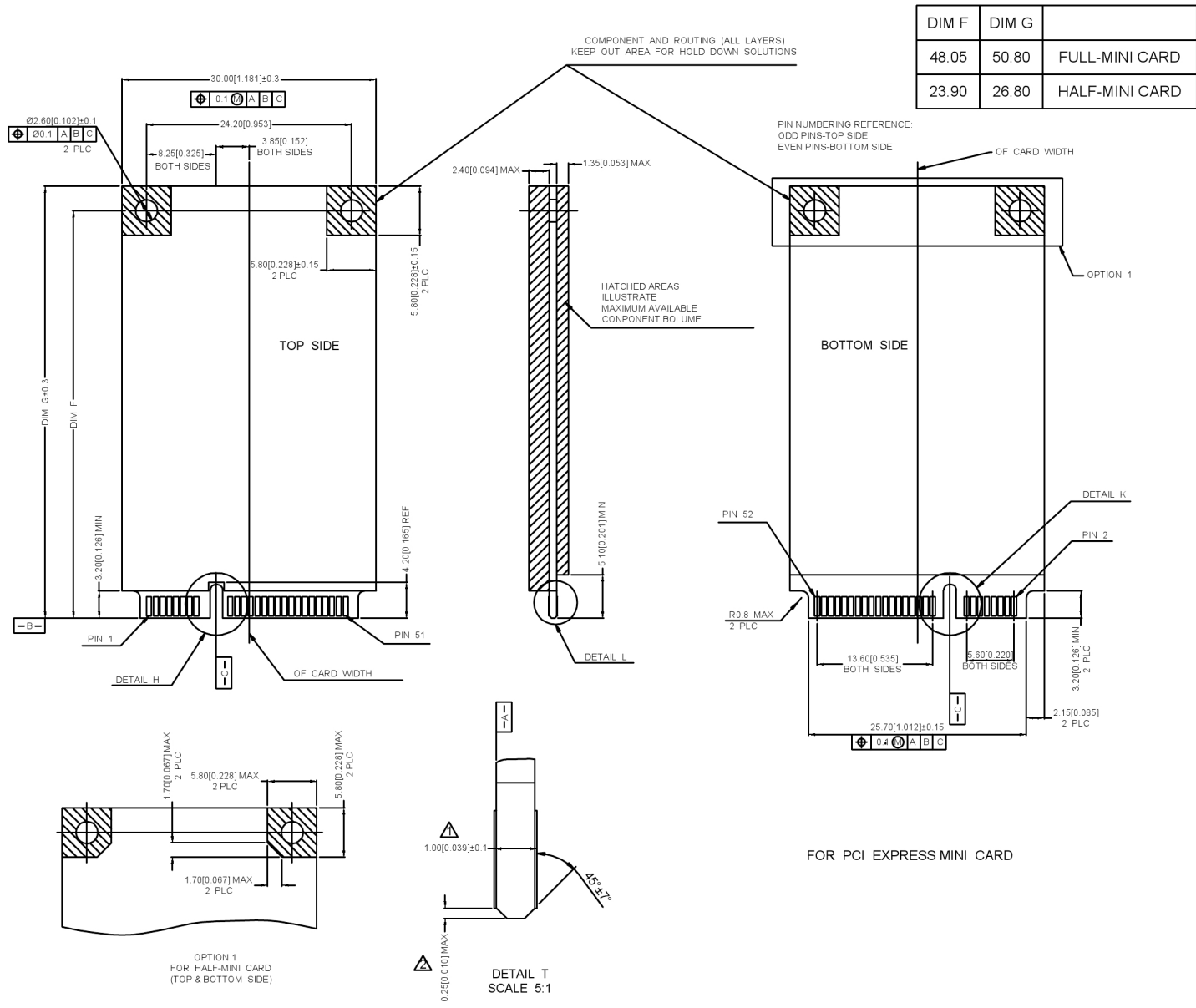

NOTES 注释:

- △ CARD THICKNESS APPLIES ACROSS TABS AND INCLUDES PLATING AND/OR METALLIZATION.
卡片厚度适用于所有接线片, 包括电镀和/或金属化。
- △ EDGE BEVEL MUST BE IPRESENT AND FREE OF CUTTING CONTACT MATERIALS BURRS FROM AND PCB
边缘斜面必须均匀且无切割接触材料毛刺和PCB

广东星坤科技股份有限公司

Δ*	日期
Δ*	日期
Δ*	日期
MARK	DESCRIPTION
文件	工程章

					ANGLAR	±5°
					L ≤ 4	±0.2
					4 < L ≤ 16	±0.3
					16 < L ≤ 63	±0.4
					L > 63	±0.5
						UNSPECIFIED TOLERANCES



DSND		SCALE: N/A	MODEL TYPE:
DWN		VIEW:	PART NO.:
CHKD		UNIT: mm/in	X1304WVS-52A-LPV10
APPD		SIZE: A4	DWG NO.:
			X-X1304WVS-52A-LPV10
WEIGHT	SHEET	REVISION	
	1/1	A0	

