



UNI-ROYAL
厚聲集團

DATA SHEET

Product Name Metal Glaze Film Fixed Resistors

Part Name MGR Series

File No. DIP-SP-006

Uniroyal Electronics Global Co., Ltd.

88#, Longteng Road, Economic & Technical Development Zone, Kunshan, Jiangsu, China

Tel +86 512 5763 1411 / 22 /33

Email marketing@uni-royal.cn

Manufacture Plant Uniroyal Electronics Industry Co., Ltd.

Aeon Technology Corporation

Royal Electronic Factory (Thailand) Co., Ltd.

Royal Technology (Thailand) Co., Ltd.

1. Scope

- 1.1 This specification for approve relates Metal Glaze Film Fixed Resistors manufactured by UNI-ROYAL.
- 1.2 Provide high stable performance against environment conditions & overload voltage
- 1.3 Can withstand High Surge Voltage
- 1.4 Wide resistance range & low TCR
- 1.5 VDE items available(File NO:40011056)
- 1.6 UL items available (File NO:E244546)

2. Part No. System

The standard Part No. includes 14 digits with the following explanation:

- 2.1 Coated type, the 1st to 3rd digits are to indicate the product type and 4th digit is the special feature.

Example: MGR0= Metal Glaze film fixed Resistors;

- 2.2 5th~6th digits:

- 2.2.1 This is to indicate the wattage or power rating. To dieting the size and the numbers,

The following codes are used; and please refer to the following chart for detail:

W=Normal Size; S=Small Size; U= Ultra Small Size; “1”~“G”to denotes“1”~“16”as Hexadecimal:

1/16W~1/2W (< 1W)

Wattage	1/2	1/3	1/4	1/5	1/6	1/8	1/10	1/16
Normal Size	W2	W3	W4	W5	W6	W8	WA	WG
Small Size	S2	S3	S4	S5	S6	S8	SA	SG
Ultra Small Size	U2	U3	U4	U5	U6	U8	UA	UG

1W~16W ($\geq 1W$)

Wattage	1	2	3	5	7	8	9	10	15
Normal Size	1W	2W	3W	5W	7W	8W	9W	AW	FW
Small Size	1S	2S	3S	5S	7S	8S	9S	AS	FS
Ultra Small Size	1U	2U	3U	5U	7U	8U	9U	AU	FU

- 2.2.2 For power rating less than 1 watt, the 5th digit will be the letters W, S or U to represent the size required & the 6th digit will be a number or a letter code.

Example: WA=1/10W; U2=1/2W-SS.

- 2.2.3 For power of 1 watt to 16 watt, the 5th digit will be a number or a letter code and the 6th digit will be the letters of W, S or U.

Example: AW=10W; 3S=3W-S

- 2.3 The 7th digit is to denote the Resistance Tolerance. The following letter code is to be used for indicating the standard Resistance Tolerance.

F=±1% G=±2% J=±5% K= ±10%

- 2.4 The 8th to 11th digits is to denote the Resistance Value.

- 2.4.1 For the standard resistance values of E-24 series, the 8th digit is “0”,the 9th & 10th digits are to denote the significant figures of the resistance and the 11th digit is the number of zeros following;

For the standard resistance values of E-96 series, the 8th digit to the 10th digits is to denote the significant figures of the resistance and the 11th digit is the 11th digit is the zeros following.

- 2.4.2 The following number s and the letter codes are to be used to indicate the number of zeros in the 11th digit:

0=10⁰ 1=10¹ 2=10² 3=10³ 4=10⁴ 5=10⁵ 6=10⁶ J=10⁻¹ K=10⁻² L=10⁻³ M=10⁻⁴

- 2.4.3 The 12th, 13th & 14th digits.The 12th digit is to denote the Packaging Type with the following codes:

A=Tape/Box (Ammo pack) B=Bulk/Box

T=Tape/Reel P=Tape/Box of PT-26 products

- 2.4.4 The 13th digit is normally to indicate the Packing Quantity of Tape/Box & Tape/Reel packaging types. The following letter code is to be used for some packing quantities:

A=500pcs B=2500pcs C=10000pcs D=20000pcs G=25000pcs H=50000pcs

- 2.4.5 For the FORMED type products, the 13th & 14th digits are used to denote the forming types of the product with the following letter codes:

MF=M-type with flattened lead wire

F0= F-type

MK= M-type with kinked lead wire

F1= F1-type

ML= M-type with normal lead wire

F2= F2-type

MC= M-type with bending lead wire

F3= F3-type

- 2.4.6 For some items, the 14th digit alone can use to denote special features of additional information with the following codes:

0=NIL

P=Panasert type

1=Avisert type 1

2=Avisert type 2

3=Avisert type 3

8=PT-58mm

9=PT-64mm

7=Lead wire(H)38mm

A=PT-83mm

C=PT-73mm

D=PT-71mm

3. Ordering Procedure

(Example: MGR 1/4W ±1% 470K Ω T/B-4000)

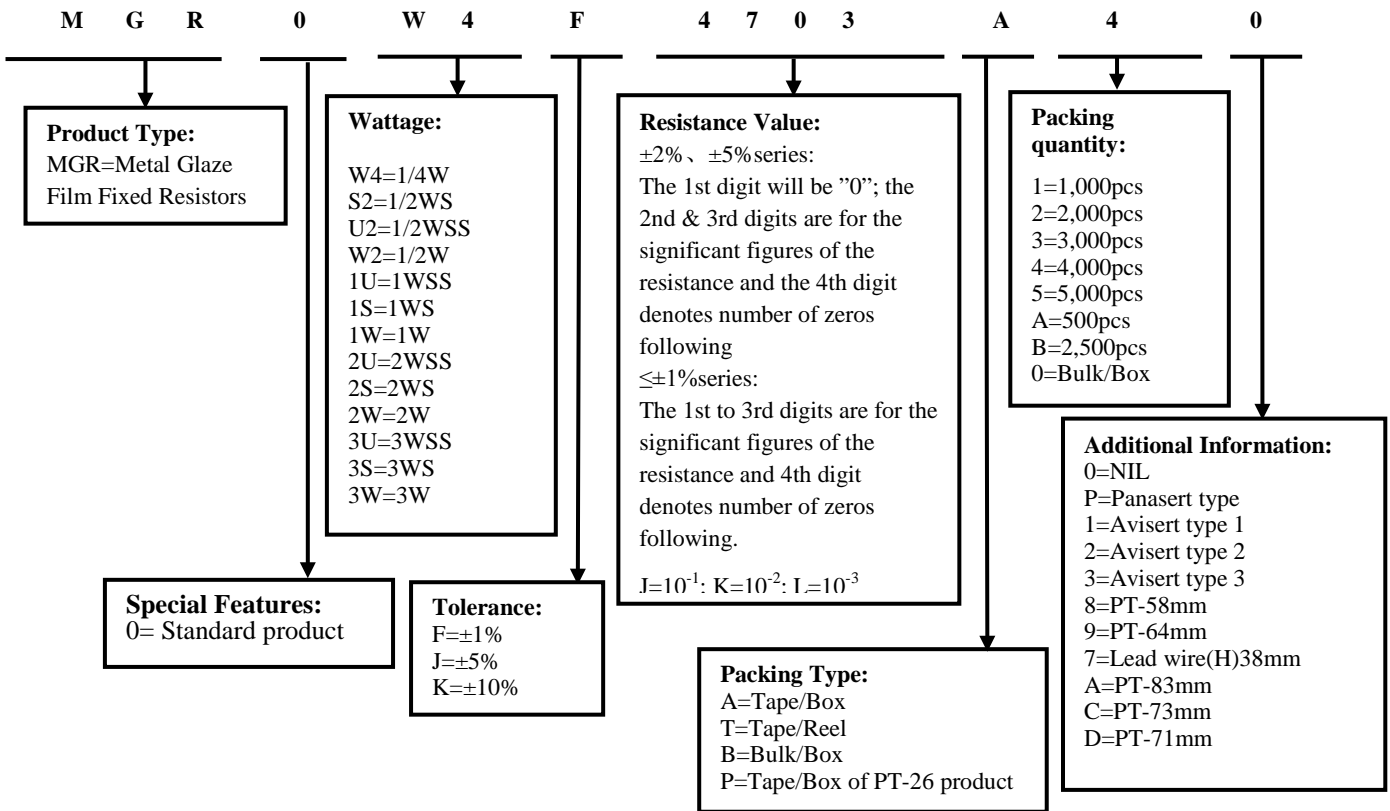

4. Marking

Resistors shall be marked with color coding
 Colors shall be in accordance with JIS C 0802

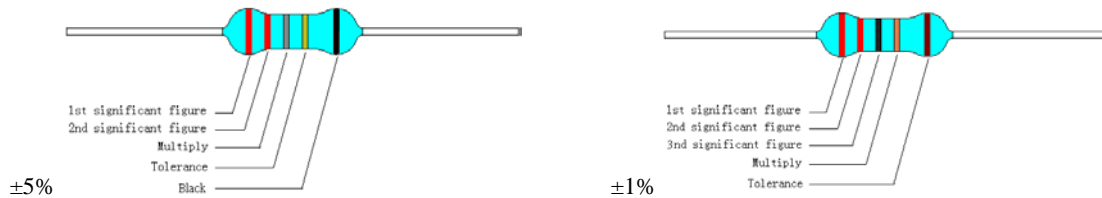

4.1 Label:

Label shall be marked with following items:

- (1) Type and style
- (2) Nominal resistance
- (3) Resistance tolerance
- (4) Quantity
- (5) Lot number
- (6) PPM

Example:

METAL GLAZE FILM FIXED RESISTORS	
WATT: 1/2W	VAL: 750KΩ
Q'TY: 1,000	TOL: 5%
LOT: 4021548	PPM:

5. Dimension & Resistance Range

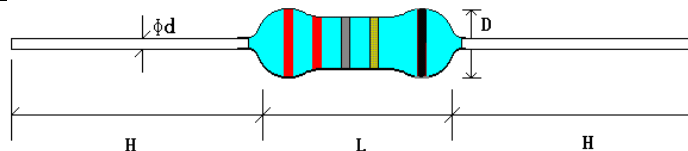

5.1 Normal size

Type	Dimension(mm)				Max Working Voltage	Max Overload Voltage	Dielectric Withstanding Voltage	Tolerance	Resistance Range
	D	L	d ±0.05	H ±3					
MGR 1/4W	2.2±0.5	6.5±1.0	0.60	28	1600V	2000V	700V	±1%	≤10MΩ
								±2%	10MΩ~100MΩ
								±5%, ±10%	1KΩ~510MΩ
MGR 1/2W	3.5±0.6	9.5±1.0	0.60	28	3500V	4000V	700V	±1%	≤10MΩ
								±2%	10MΩ~100MΩ
								±5%, ±10%	1KΩ~510MΩ
MGR 1W	4.0±0.6	11.5±1.0	0.75	25	3500V	4000V	1000V	±1%	≤10MΩ
								±2%	10MΩ~100MΩ
								±5%, ±10%	1KΩ~1GΩ
MGR 2W	5.0±0.6	15.5±1.0	0.80	28	3500V	4000V	1000V	±1%	≤10MΩ
								±2%	10MΩ~100MΩ
								±5%, ±10%	1KΩ~1GΩ
MGR 3W	6.0±0.6	17.5±1.0	0.80	28	3500V	4000V	1000V	±1%	100KΩ~1MΩ
								±5%, ±10%	1KΩ~100MΩ

5.2 Small Size & Extra Small Size

Type	Dimension(mm)				Max Working Voltage	Max Overload Voltage	Dielectric Withstanding Voltage	Tolerance	Resistance Range
	D	L	d ±0.05	H ±3					
MGR 1/2WS	2.2±0.5	6.5±1.0	0.60	28	500V	700V	500V	±1%	100KΩ~1MΩ
								±5%, ±10%	1KΩ~33MΩ
MGR 1WS	3.5±0.6	9.5±1.0	0.60	28	700V	1000V	700V	±1%	100KΩ~1MΩ
								±5%, ±10%	1KΩ~33MΩ
MGR 2WS	4.5±0.6	11.5±1.0	0.75	25	1000V	1400V	700V	±1%	100KΩ~1MΩ
								±5%, ±10%	1KΩ~33MΩ
MGR 3WSS	4.5±0.6	11.5±1.0	0.75	25	1000V	1400V	700V	±1%	100KΩ~1MΩ
								±5%, ±10%	1KΩ~33MΩ
MGR 3WS	5.0±0.6	15.5±1.0	0.80	28	1000V	1400V	700V	±1%	100KΩ~1MΩ
								±5%, ±10%	1KΩ~33MΩ

6. Derating Curve

Resistors shall have a power rating based on continuous load operation at an ambient temperature from -55°C to 70°C. For temperature in excess of 70°C, the load shall be derate as shown in figure 1

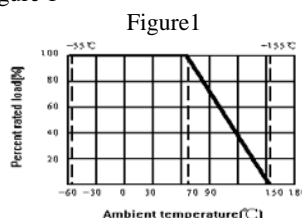

6.1 Voltage rating:

Resistors shall have a rated direct-current (DC) continuous working voltage or an approximate sine-wave root-mean-square (RMS) alternating-current (AC) continuous working voltage at commercial-line frequency and waveform corresponding to the power rating, as determined from the following formula:

$$RCWV = \sqrt{P \times R}$$

Where: RCWV = Rated DC or RMS AC continuous working voltage at commercial-line frequency and waveform (VOLT.)

P = power rating (WATT.) R = nominal resistance (OHM)

In no case shall the rated DC or RMS AC continuous working voltage be greater than the applicable maximum value.

The overload voltage is 2.5 times RCWV or Max. Overload voltage whichever is less.

7. Structure

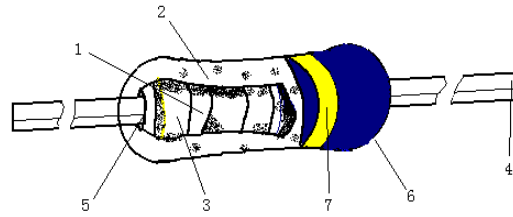

No.	Name	Material
1	Basic Body	Rod type ceramics
2	Resistor	Metal Glaze Film (Ruthenium Oxide)
3	End Cap	Steel (Tin-Plated iron surface)
4	Lead Wire	Tin solder coated copper wire
5	Joint	By Welding
6	Coating	Color: 1/4W: (Blue) 1/2WS,1/2W, 1WS, 1W, 2WS,2W, 3WSS,3WS 3W: (Sky Blue)
7	Color Code	Epoxy Resin

8. Performance Specification

Characteristic	Limits	Test Methods (GB/T5729&JIS-C-5201&IEC60115-1)
Temperature Coefficient	$\cong \pm 200 \text{PPM}/^\circ\text{C}$	4.8 Natural resistance changes per temp. Degree centigrade $\frac{R_2 - R_1}{R_1(t_2 - t_1)} \times 10^6 \text{ (PPM}/^\circ\text{C)}$ R ₁ : Resistance Value at room temperature (t ₁) ; R ₂ : Resistance at test temperature (t ₂) t ₁ : +25°C or specified room temperature t ₂ : Test temperature (-55°C or 125°C)
Short-time overload	$\Delta R/R \leq \pm(1\% + 0.05 \Omega)$, with no evidence of mechanical damage	4.13 Permanent resistance change after the application of a potential of 2.5 times rcwv for 5 seconds.
Dielectric withstanding voltage	With no evidence of flashover, mechanical damage, arcing or insulation breakdown	4.7 Resistors shall be clamped in the trough of a 90° metallic v-block and shall be tested at ac potential respectively specified in the above list for 60-70 seconds.
Pulse overload	$\Delta R/R \leq \pm(2\% + 0.05)$, with no evidence of mechanical damage	4.28 Resistance change after 10,000 cycles (1 second "ON", 25 seconds "OFF") at 4 times RCWV.
Resistance to soldering heat	$\Delta R/R \leq \pm(1\% + 0.05 \Omega)$ with no evidence of mechanical damage	4.18 Permanent resistance change when leads immersed to a point 2.0-2.5mm from the body in 260°C ± 5°C solder for 10 ± 1 seconds.
Resistance to solvent	No deterioration of protective coatings & markings	4.29 Specimens shall be immersed in a bath of IPA completely for 5 ± 0.5 min. With ultrasonic
Terminal strength	No evidence of mechanical damage	4.16 Direct load: Resistance to a 2.5 kg direct load for 10 seconds in the direction of the longitudinal axis of the terminal leads. Twist test: Terminal leads shall be bent through 90° at a point of about 6mm from the body of the resistor and shall be rotated through 360° about the original axis of the bent terminal in alternating direction for a total of 3 rotations.

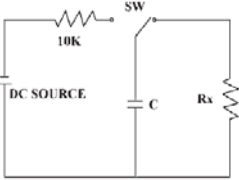
Solderability	Coverage must be over 95%.	4.17 The area covered with a new, smooth, clean, shiny and continuous surface free from concentrated pinholes. Test temp. Of solder:245°C±3°C Dwell time in solder: 2~3seconds.																														
Rapid change of temperature	$\Delta R/R \leq \pm(1\%+0.05 \Omega)$ with no evidence of mechanical damage	4.19 30 min at -55 °C and 30 min at 155°C; 100 cycles.																														
Load life in humidity	$\Delta R/R \leq \pm(5\%+0.05 \Omega)$ with no evidence of mechanical damage.	7.9 resistance change after 1,000 hours (1.5 hours “ON”,0.5 hour “OFF”) at RCWV in a humidity test chamber controlled at 40°C±2°C and 90 to 95% relative humidity.																														
Load life	$\Delta R/R \leq \pm(5\%+0.05 \Omega)$ with no evidence of mechanical damage	4.25.1 permanent resistance change after 1,000 hours operating at RCWV with duty cycle of 1.5 hours “ON”, 0.5 hour “OFF” at 70°C±2°C ambient.																														
Surge withstanding voltage	$\Delta R/R \leq \pm(20\%+0.05 \Omega)$ with no evidence of mechanical damage Test circuit:  Normal size: The discharge cycle is repeated in above circuit: 2.5 seconds “ON” ,2.5 “OFF” ,50 cycles, C=0.001uf. Small Size: The discharge cycle is repeated in above circuit: 2.5 seconds “ON” ,2.5 seconds “OFF” ,10 cycles, C=0.01uf.	The following discharge cycle is repeated in the circuit in the left fig. 2.5 sec. ON, 2.5 sec. OFF,50cycles Applied voltage (DC source) <table border="1" data-bbox="858 873 1465 974"> <tr> <td>Resistance Range</td> <td>1/4W, 1/2W, 1W, 2W, 3W,</td> </tr> <tr> <td>$\geq 100K\Omega$</td> <td>10KV</td> </tr> </table>	Resistance Range	1/4W, 1/2W, 1W, 2W, 3W,	$\geq 100K\Omega$	10KV																										
		Resistance Range	1/4W, 1/2W, 1W, 2W, 3W,																													
$\geq 100K\Omega$	10KV																															
The following discharge cycle is repeated in the circuit in the left fig. 2.5 sec. “ON”, 2.5 sec“OFF”, 10 cycles Applied voltage (DC source) <table border="1" data-bbox="877 1115 1444 1467"> <thead> <tr> <th>Resistance range</th> <th>1/2WS</th> <th>1WS</th> <th>2WS</th> </tr> </thead> <tbody> <tr> <td>100K-1M</td> <td>3000V</td> <td>4000V</td> <td>5000V</td> </tr> <tr> <td>1M1-6M2</td> <td>4000V</td> <td>5000V</td> <td>6000</td> </tr> <tr> <td>$\geq 6M8$</td> <td>6000V</td> <td>8000V</td> <td>9000V</td> </tr> <tr> <th>Resistance range</th> <th>3WSS</th> <th>3WS</th> <th>/</th> </tr> <tr> <td>100K-1M</td> <td>5000V</td> <td>8000V</td> <td>/</td> </tr> <tr> <td>1M1-6M2</td> <td>6000V</td> <td>9000V</td> <td>/</td> </tr> <tr> <td>$\geq 6M8$</td> <td>9000V</td> <td>10000V</td> <td>/</td> </tr> </tbody> </table>	Resistance range	1/2WS	1WS	2WS	100K-1M	3000V	4000V	5000V	1M1-6M2	4000V	5000V	6000	$\geq 6M8$	6000V	8000V	9000V	Resistance range	3WSS	3WS	/	100K-1M	5000V	8000V	/	1M1-6M2	6000V	9000V	/	$\geq 6M8$	9000V	10000V	/
Resistance range	1/2WS	1WS	2WS																													
100K-1M	3000V	4000V	5000V																													
1M1-6M2	4000V	5000V	6000																													
$\geq 6M8$	6000V	8000V	9000V																													
Resistance range	3WSS	3WS	/																													
100K-1M	5000V	8000V	/																													
1M1-6M2	6000V	9000V	/																													
$\geq 6M8$	9000V	10000V	/																													
Low Temperature Storage	$\Delta R/R \leq \pm(5\%+0.05 \Omega)$ with no evidence of mechanical damage	IEC 60068-2-1 (Aa) Lower limit temperature , for 2H.																														
High Temperature Exposure	$\Delta R/R \leq \pm(5\%+0.05 \Omega)$ with no evidence of mechanical damage	MIL-STD-202 108A Upper limit temperature , for 16H.																														

9. Packing

9.1 Tapes in Box Packing

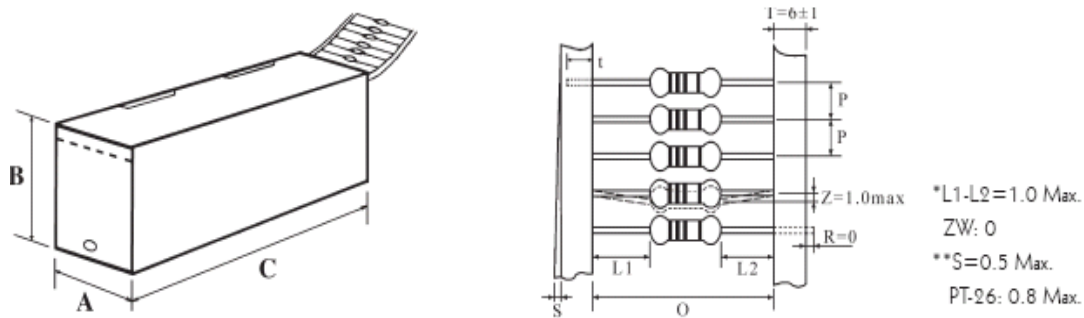

Dimension of T/B (mm)

Part No.	O	P	A±5	B±5	C±5	Qty/Box
MGR 1/4W	52±1	5±0.3	75	116	255	4000 PCS
MGR 1/2W	52±1	5±0.3	75	70	255	1000 PCS
MGR 1W	52±1	5±0.3	86	82	255	1000 PCS
MGR 2W	64±5	10±0.5	90	119	255	1000 PCS
MGR 3W	64±5	10±0.5	90	88	255	500 PCS
MGR 1/2WS	52±1	5±0.3	75	116	255	4000 PCS
MGR 1WS	52±1	5±0.3	75	70	255	1000 PCS
MGR 2WS	52±1	5±0.3	86	82	255	1000 PCS
MGR 3WSS	52±1	5±0.3	86	82	255	1000 PCS
MGR 3WS	64±5	10±0.5	90	119	255	1000 PCS

9.2 Tapes in Reel Packing

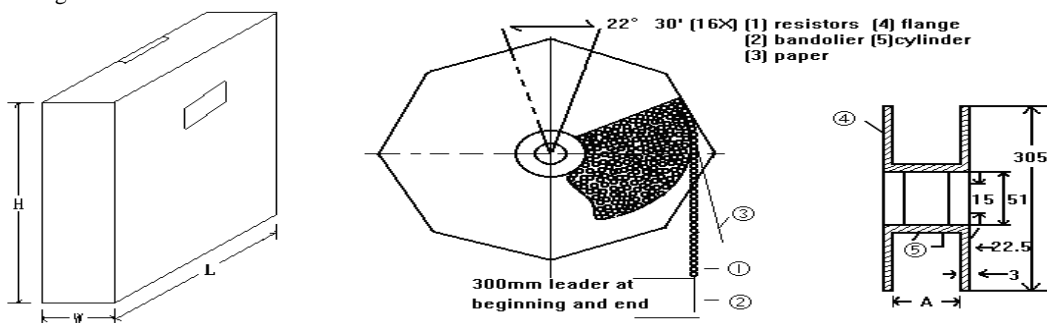

Dimension of Reel (mm)

Part No.	O	A	W±5	H±5	L±5	Qty/Box
MGR 1/4W	52±1	73±2	85	295	293	5,000pcs
MGR 1/2W	52±1	73±2	85	295	293	2,500pcs
MGR 1W	52±1	73±2	85	295	293	1,000pcs
MGR 2W	64±5	80±5	95	295	293	1,000pcs
MGR 3W	64±5	80±5	95	295	293	1,000pcs
MGR 1/2WS	52±1	73±2	85	295	293	5,000pcs
MGR 1WS	52±1	73±2	85	295	293	2,500pcs
MGR 2WS	52±1	73±2	85	295	293	1,000pcs
MGR 3WSS	52±1	73±2	85	295	293	1,000pcs
MGR 3WS	64±5	80±5	95	295	293	1,000pcs

9.3 Bulk in Box Packing

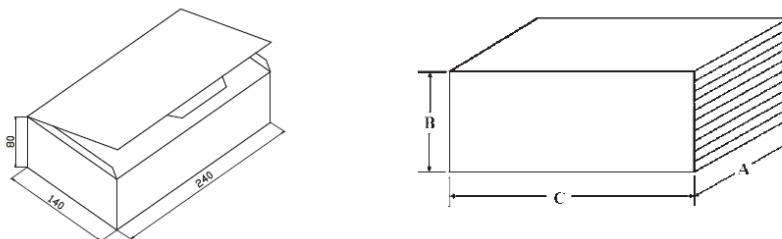

Dimension of Box (mm)				
Part No.	A±5	B±5	C±5	Qty. of Bag/Box
MGR 1/4W	140	80	240	500/10,000pcs
MGR 1/2W	140	80	240	250/5,000pcs
MGR 1W	140	80	240	100/2,500pcs
MGR 2W	140	80	240	100/1,500pcs
MGR 3W	140	80	240	100/1,000pcs
MGR 1/2WS	140	80	240	500/10,000pcs
MGR 1WS	140	80	240	250/5,000pcs
MGR 2WS	140	80	240	100/2,500pcs
MGR 3WSS	140	80	240	100/2,500pcs
MGR 3WS	140	80	240	100/1,500pcs

10. Note

- 10.1. UNI-ROYAL recommend products store in warehouse with temperature between 15 to 35°C under humidity between 25 to 75%RH. Even under storage conditions recommended above, solder ability of products will be degraded stored over 1 year old.
- 10.2. Cartons must be placed in correct direction which indicated on carton, otherwise the reel or wire will be deformed.
- 10.3. Storage conditions as below are inappropriate:
 - a. Stored in high electrostatic environment
 - b. Stored in direct sunshine, rain, snow or condensation.
 - c. Exposed to sea wind or corrosive gases, such as Cl₂, H₂S, NH₃, SO₂, NO₂, Br etc.

11. Record

Version	Description	Page	Date	Amended by	Checked by
1	First version	1~7	Mar.20, 2018	Haiyan Chen	Nana Chen
2	Modify characteristic	5~6	Feb.19, 2019	Haiyan Chen	Yuhua Xu
3	Update VDE and UL certificate numbers	1	Sep.09, 2021	Haiyan Chen	Yuhua Xu
4	Modify the temperature coefficient test conditions	5	Oct.28, 2022	Haiyan Chen	Yuhua Xu

© Uniroyal Electronics Global Co., Ltd. All rights reserved. Specification herein will be changed at any time without prior notice