

3D View

NOTES:

1:MATERIAL

1-1: SUS-301 THICKNE=0.10MM

2:SPECIFICATIONS

2-1: RATED CURRENT: 1.0A

2-2: VOLTAGE RATING: 1.5V

2-3: CONTACT RESISTANCE: 80mΩ/MAX

2-4: WELDING THRUST: ≥3KG

2-5: OPERATING TEMPERATURE: -40°C~+85°C

3:DURABILITY: 1500 CYCLES

4:SALT SPRAY TIME: 24H

5:ELECTROPLATE: THE NICKEL-PLATED SUBSTRATE IS 50μ" MIN

6:REQUIREMENTS

6-1:TERMINAL TO EAT FULL TIN,NOTPEELING, WELDING OBVIOUS COLOR AND OTHER ADVERSE

6-2:ROHS.REACH.HF HALOGER ADVERSE OF DOMESTIC AND INTERNATIONAL ENVIRONMNTAL REQUIREMENTS

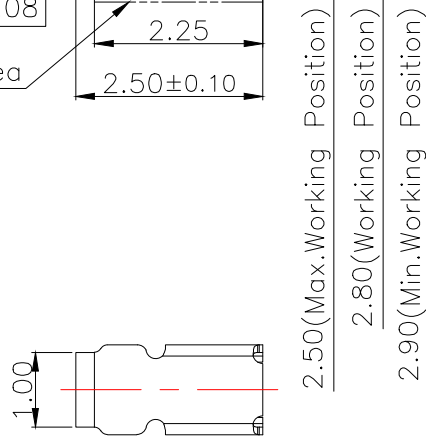
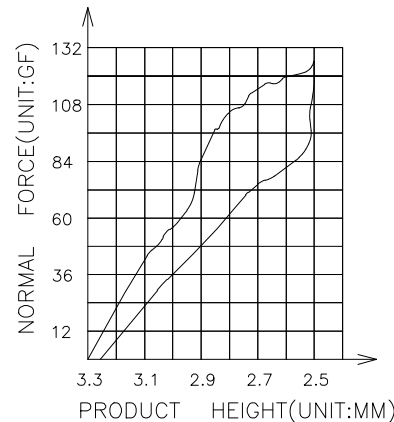
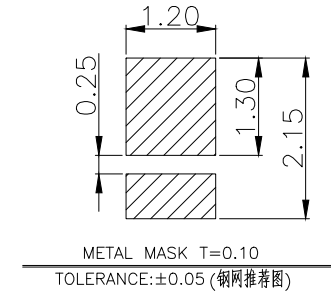
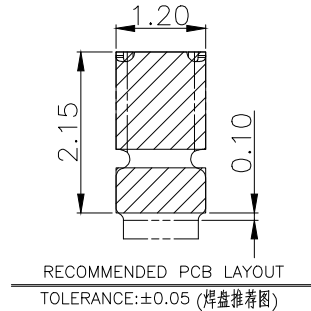
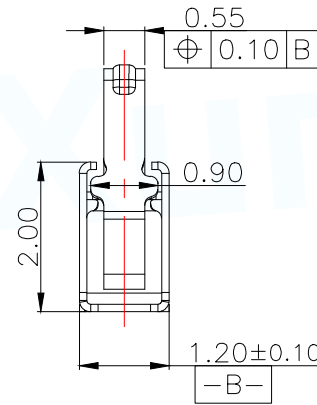
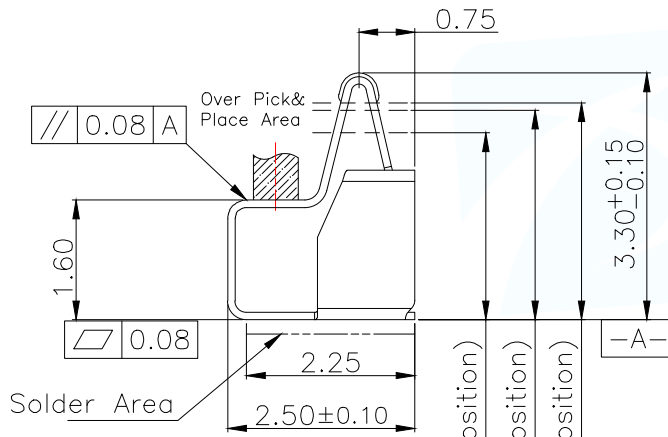

MANUFACTURE DWG		东莞市讯普电子科技有限公司 DongGuan XunPu Electronics Co.,Ltd	
UNLESS OTHERWISE SPECIFIED TOLERANCES			TITLE: 天线弹片 L2.50*W1.20*H3.30
			PAR ASP-D3301-BP1
DECIMALS:	ANGLES:		DWN Lucas
X.:±0.30	X':±2'		CHKD Ethan
X.X:±0.20	X.X':±1'		APVD Jacob
X.XX:±0.15	X.XX':±0.5'	CUSTOMER COPY	SCALE:1:1 UNIT:MM
		SIZE:A4	UNIT:MM
		SHEET:1F1	REV:A

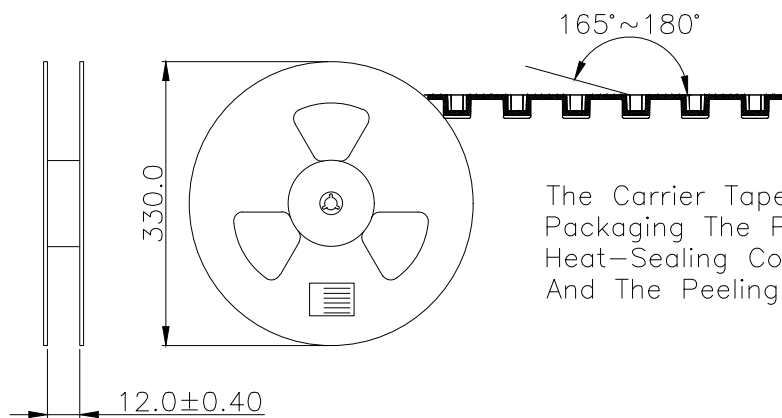
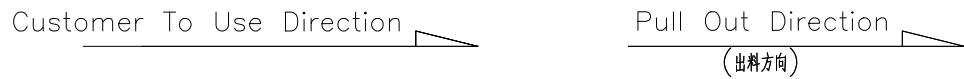
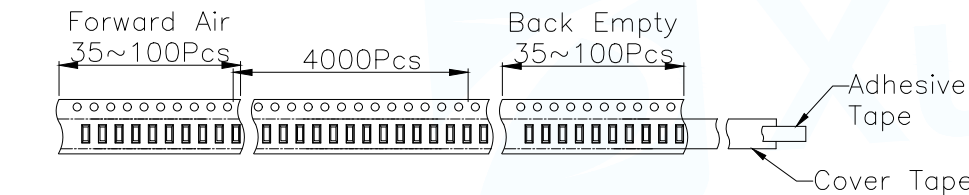
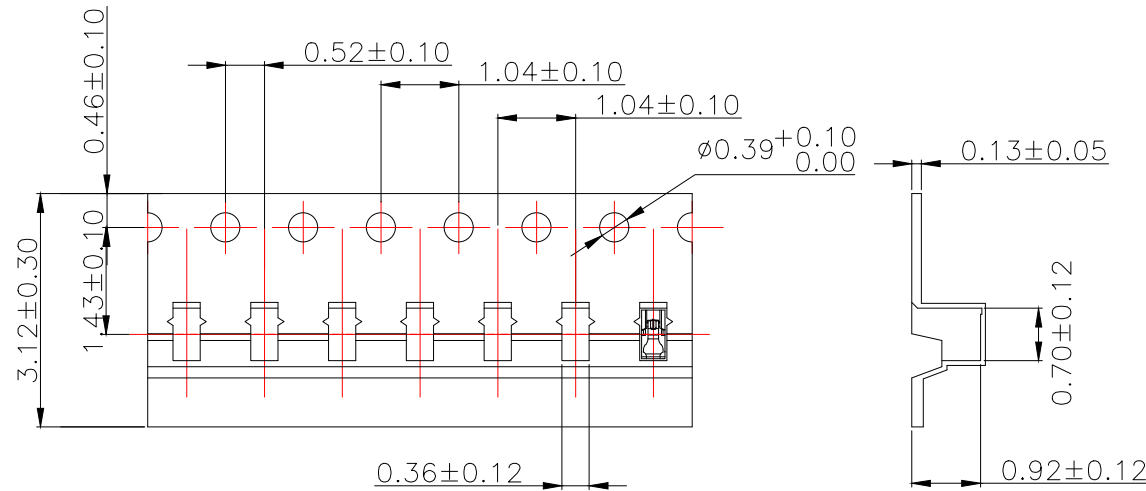

The Carrier Tape Is Heat-Sealed Packaging The Peeling Angle Of The Heat-Sealing Cover Tape Is 165°~180° And The Peeling Force Is 30~120g.

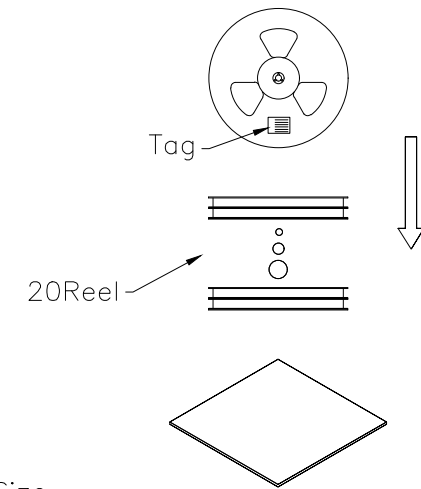

Carton Size 290*330*4 K3K

Carton Size 345*345*360 K=K

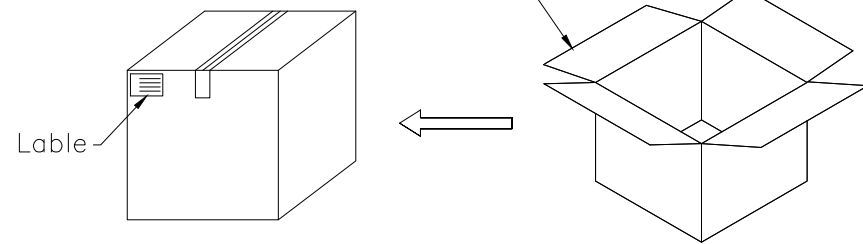

MANUFACTURE DWG		东莞市讯普电子科技有限公司 DongGuan XunPu Electronics Co.,Ltd	
UNLESS OTHERWISE SPECIFIED TOLERANCES			TITLE: 天线弹片 L2.50*W1.20*H3.30
			PAR ASP-D3301-BP1
DECIMALS:	ANGLES:		DWN Lucas
X.:±0.30	X.':±2°		CHKD Ethan
X.X:±0.20	X.X':±1°	APVD Jacob	SCALE:1:1
X.XX:±0.15	X.XX':±0.5°	CUSTOMER COPY	SIZE:A4
			UNIT:MM
			SHEET:1F1
			REV:A