

客 户 :

Customer

客 户 料 号 :

Customer P/N

物 料 名 称 : 共模滤波电感

Item Name

型 号 : RSCM7060系列规格书

P/N

承认书编号 : S23080901

Spec No.

版 本 号 : A0

Version No.

制 造 商 Manufacture	
拟 制 Prepared	
审 核 Checked	
批 准 Approved	
日 期 Date	2023/8/9

客 户 承 认 Approved by Customer	
批 准 Approved	
日 期 Date	

备 注:

Remark

1. 在使用产品前, 用户必须确认此产品是否适用于自身设计, 瑞申仅保证产品符合此份承认书的规格。
Before use, customer should confirm whether this product is suitable for their design, Ruishen only ensure products meet this specification.
2. 本承认书的数据更改, 必须经双方确认, 任何一方单独修改无效。
This specification data change must be confirmed by both parties, any individual modification is invalid.
3. 如客户未回签承认书即下订单, 则视为承认此份承认书。
If customer placed orders without signing back this specification, it is regarded as recognition.



1 外形尺寸(mm) Appearance and dimensions

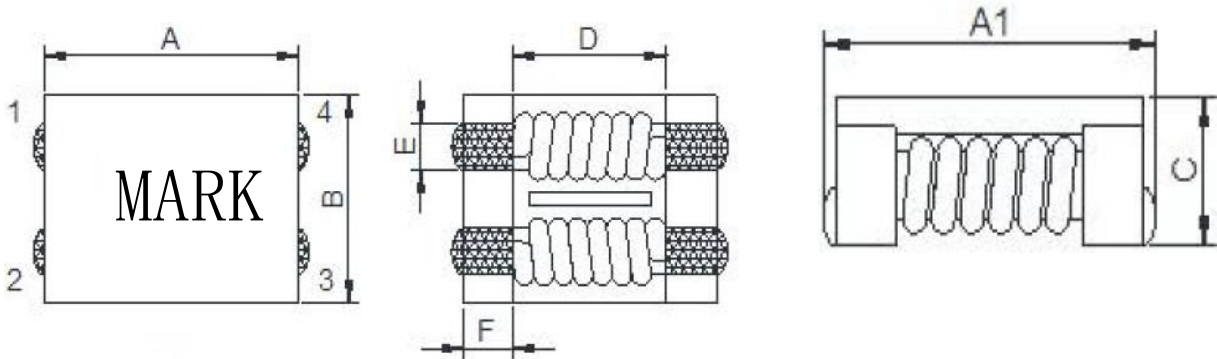

A	A1	B	C	D	E	F
7.0±0.5	7.5±0.5	6.0±0.5	3.8 Max	3.5Typ.	1.5Typ.	1.7Typ.

2 原理图 Schematic

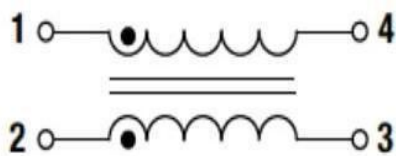

3 参考基板尺寸(mm) Reference PCB pattern

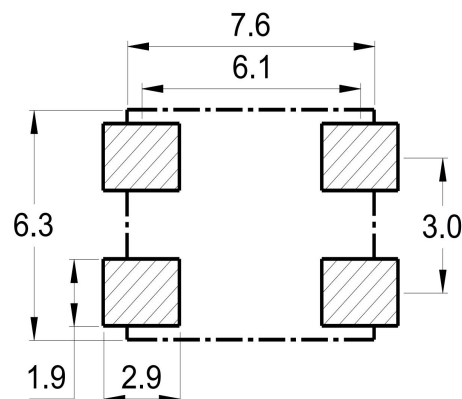

4 电气特性 Electrical characteristics

型号 Type No.	Impedance (Ω) @100MHz		直流电阻 DCR mΩ	额定电流 IDC A	Insulation Resistance
	Min.	Typ.	Max.	Max.	(MΩ) Min.
RSCM7060-400	40	70	5	15	10
RSCM7060-101	100	140	10	9	10
RSCM7060-301	225	300	10	5	10
RSCM7060-501	275	450	10	5	10
RSCM7060-701	500	700	15	4	10
RSCM7060-102	800	1020	17	3	10
RSCM7060-132	910	1300	21	2.5	10
RSCM7060-272	2000	2700	63	1	10
RSCM7060-302	2500	3000	75	0.9	10

※1 温升电流：使产品温度上升到 $\Delta T40^{\circ}\text{C}$ 时所加载的直流电流值($T_a=25^{\circ}\text{C}$)。

Heat rating current: The value of DC current when product temperature rise is $\Delta T40^{\circ}\text{C}$ ($T_a=25^{\circ}\text{C}$).

※2 特别提示：线路设计，组件布局，使用频率，散热系统等均会影响产品温度，请务必验证产品实际发热状况。

Special remind: Circuit design, component placement, frequency, cooling system and etc. all will affect the product temperature. Please verify the actual product temperature in the final application.

※3 所有数据基于环境温度 25°C 条件下测试。

All data is tested on 25°C ambient temperature.

※4 工作温度范围： $-40^{\circ}\text{C} \sim +125^{\circ}\text{C}$ （包含产品发热）

Operating temperature range : $-40^{\circ}\text{C} \sim +125^{\circ}\text{C}$ (Including self-temperature rise)



5 阻抗VS频率曲线 Impedance vs Frequency Curve

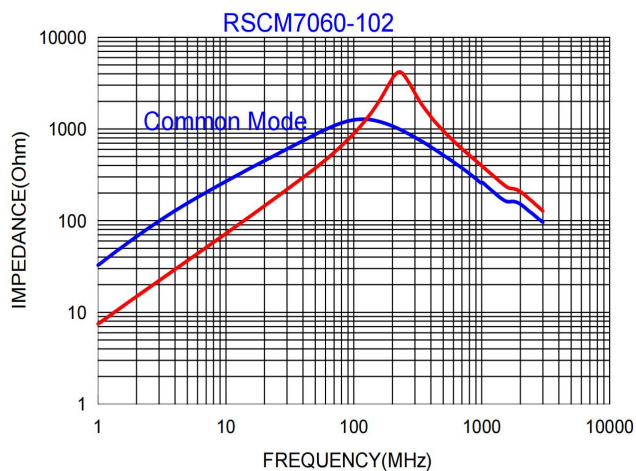
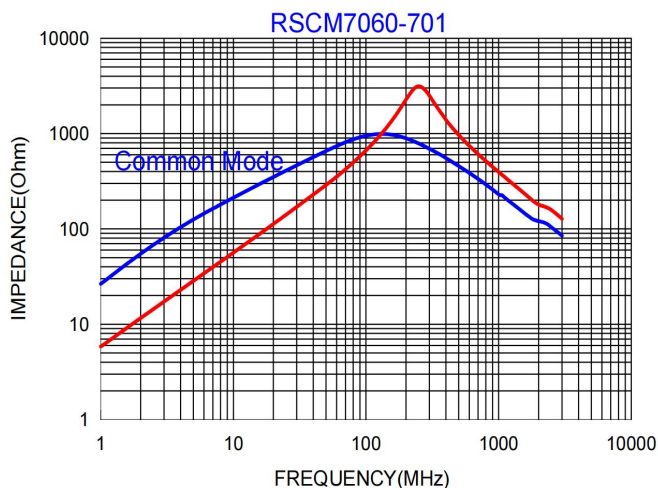
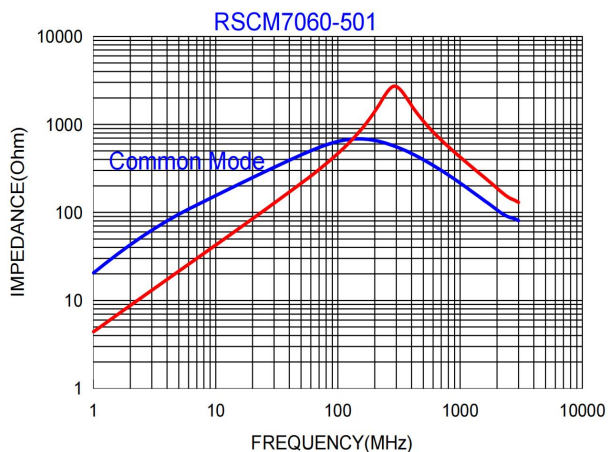
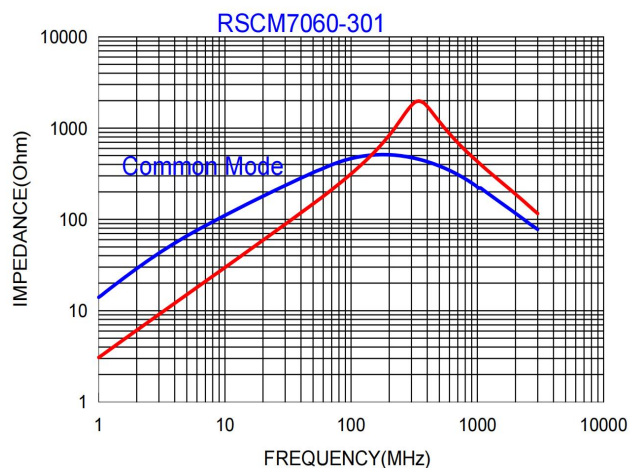
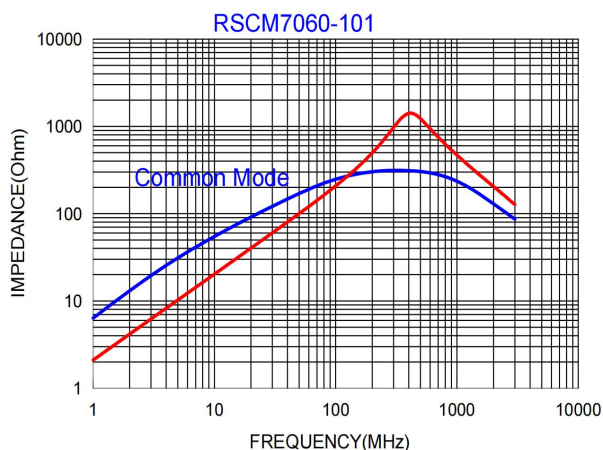
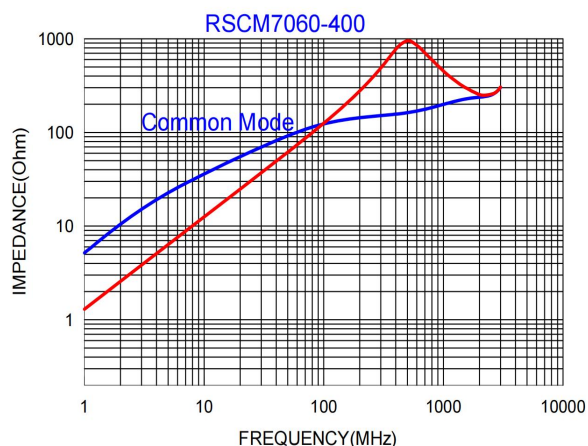

5 阻抗VS频率曲线
Impedance vs Frequency Curve

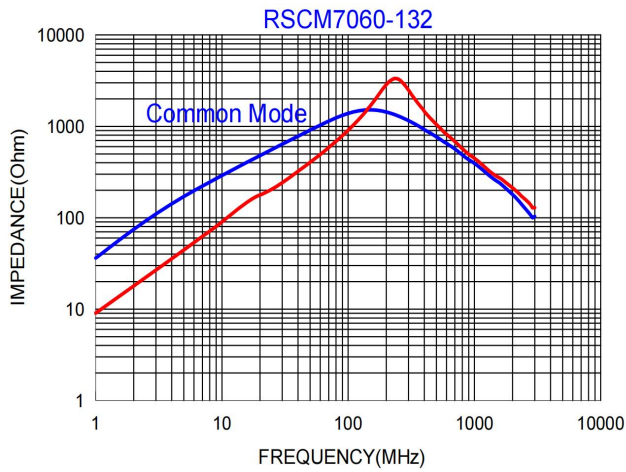

6 包装规格 (Dimensions in mm) Packaging specification

Reel Dimensions (mm)
卷盘尺寸(mm)

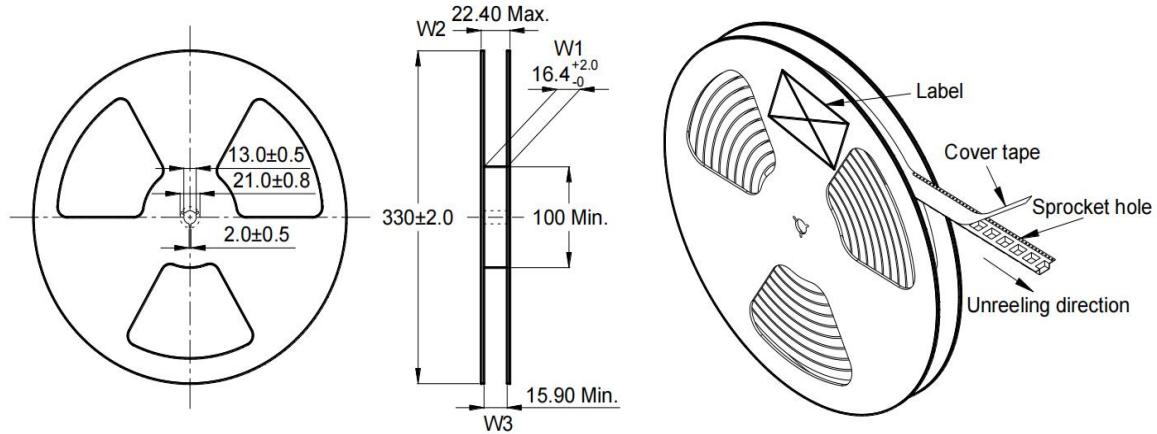

Carrier Tape Dimensions (mm)
载带尺寸

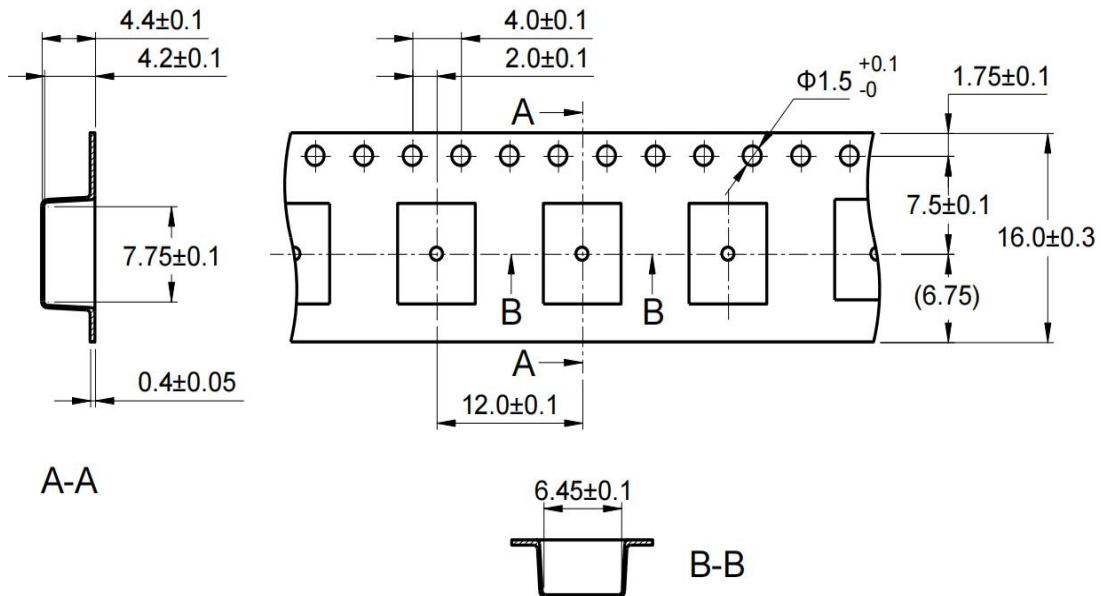

※ Packing is referred to the international standard IEC 60286-3.
包装参照国际标准 IEC 60286-3。

1500 pcs/reel

