

3D View

NOTES:

- 1: MATERIAL
  - 1-1: SUS-301 THICKNE=0.10MM
- 2: SPECIFICATIONS
  - 2-1: RATED CURRENT: 1.0A
  - 2-2: VOLTAGE RATING: 1.5V
  - 2-3: CONTACT RESISTANCE: 80mΩ/MAX
  - 2-4: WELDING THRUST: ≥3KG
  - 2-5: OPERATING TEMPERATURE: -40°C~+85°C
- 3: DURABILITY: 1500 CYCLES
- 4: SALT SPRAY TIME: 24H
- 5: ELECTROPLATE: THE NICKEL-PLATED SUBSTRATE IS 50u" MIN
- 6: REQUIREMENTS
  - 6-1: TERMINAL TO EAT FULL TIN, NOT PEELING, WELDING OBVIOUS COLOR AND OTHER ADVERSE
  - 6-2: ROHS, REACH, HF HALOGEN ADVERSE OF DOMESTIC AND INTERNATIONAL ENVIRONMENTAL REQUIREMENTS

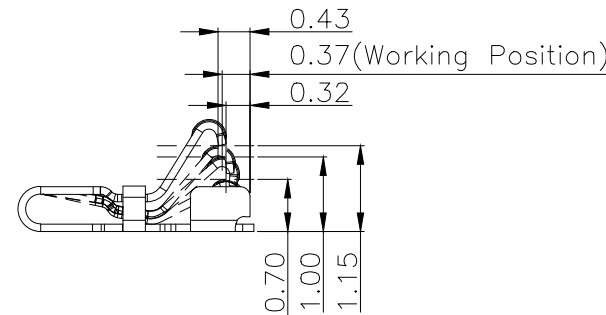
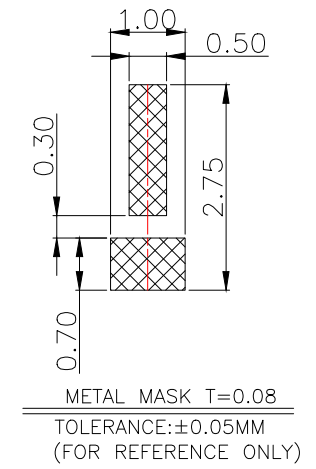
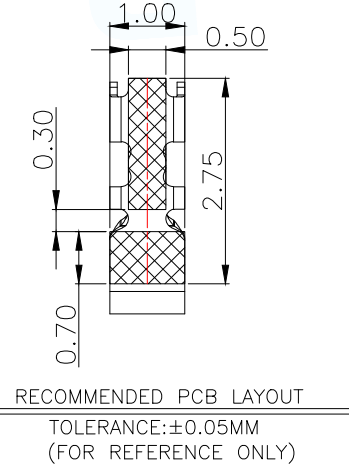
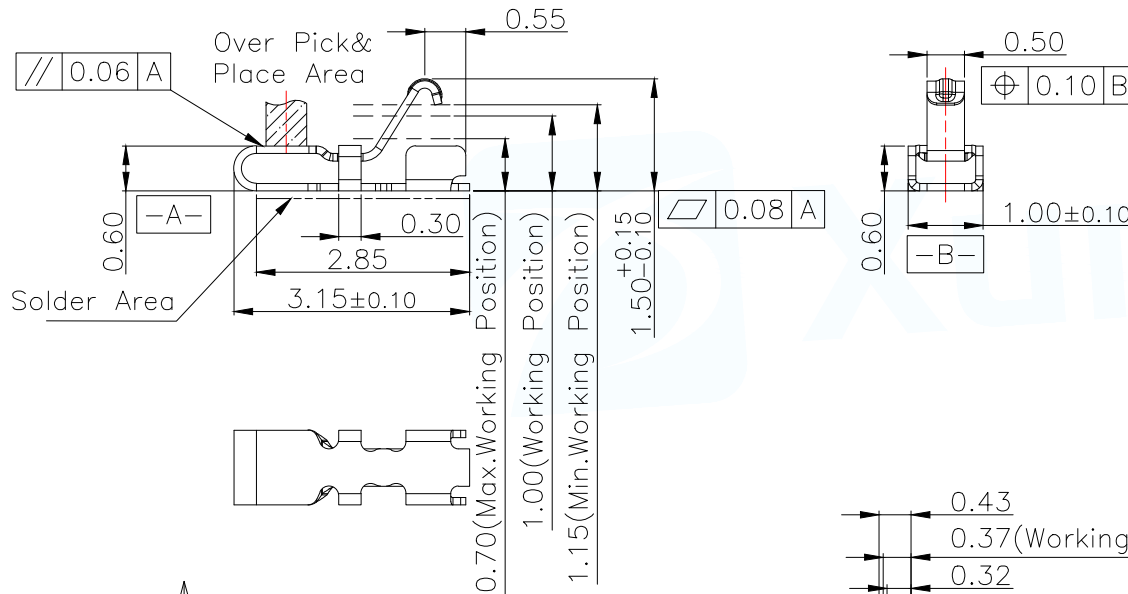

(For Reference Only)  
Stated At Compression

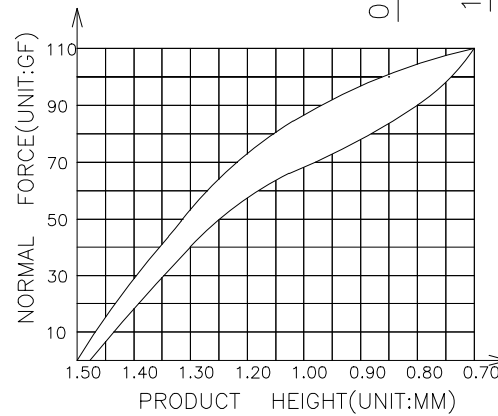

MANUFACTURE DWG		东莞市讯普电子科技有限公司 DongGuan XunPu Electronics Co., Ltd	
UNLESS OTHERWISE SPECIFIED TOLERANCES			TITLE: 天线弹片 L3.15*W1.00*H1.50
			PAR ASP-D1505-B01
DECIMALS:	ANGLES:		DWN Lucas
X.:±0.30	X':±2°		CHKD Ethan
X.X:±0.20	X.X':±1°		APVD Jacob
X.XX:±0.15	X.XX':±0.5°	CUSTOMER COPY	SCALE:1:1 UNIT:MM
		SIZE:A4	SHEET:1F1
			REV:A

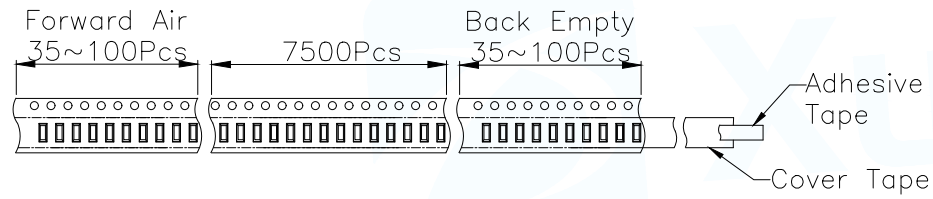
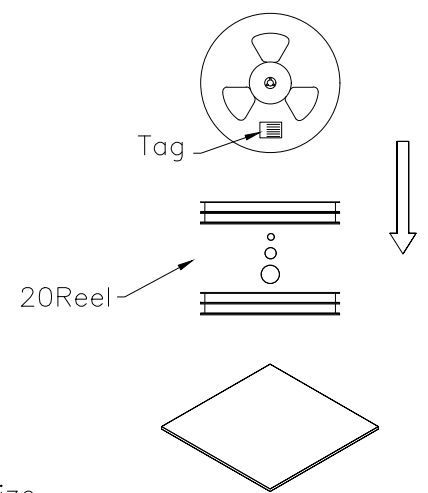
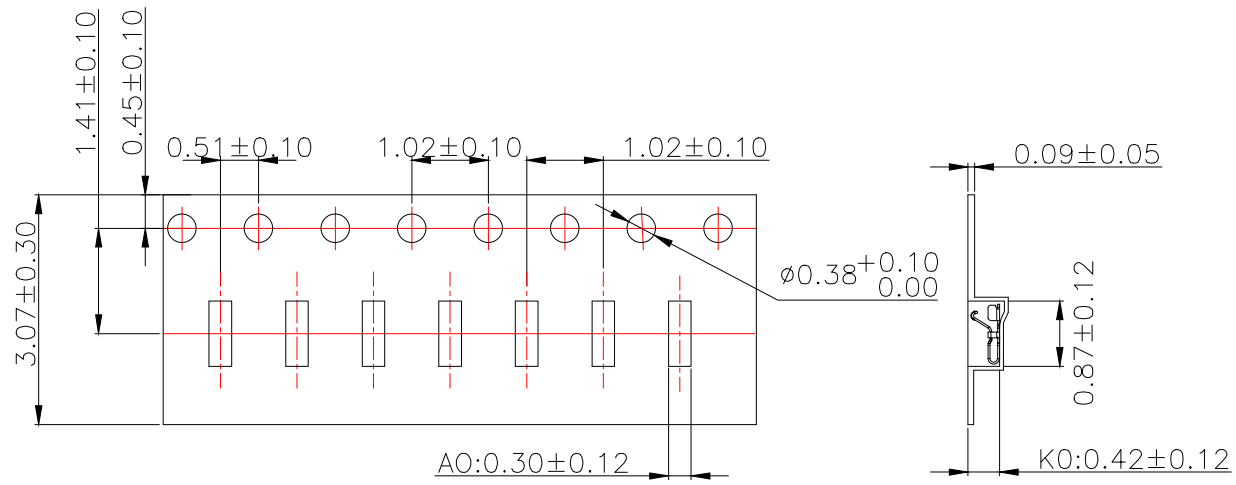

Carton Size  
290\*330\*4 K3K

Carton Size  
345\*345\*360 K=K

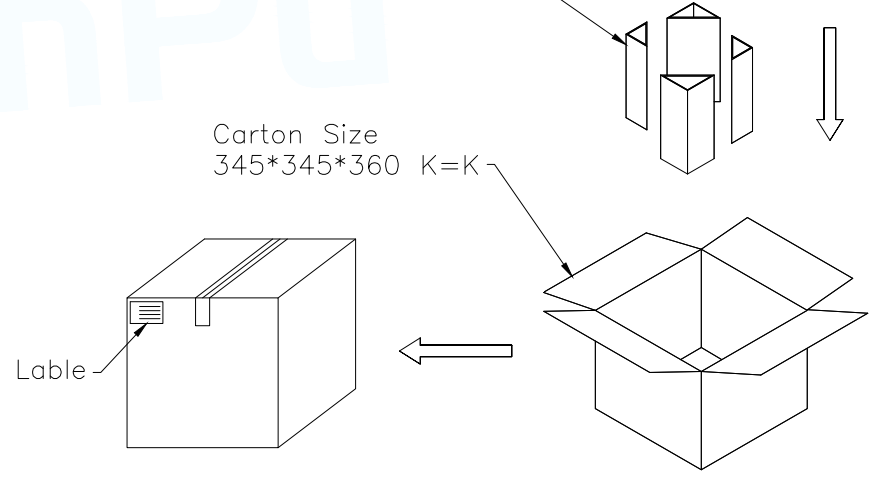

Customer To Use Direction Pull Out Direction (出料方向)

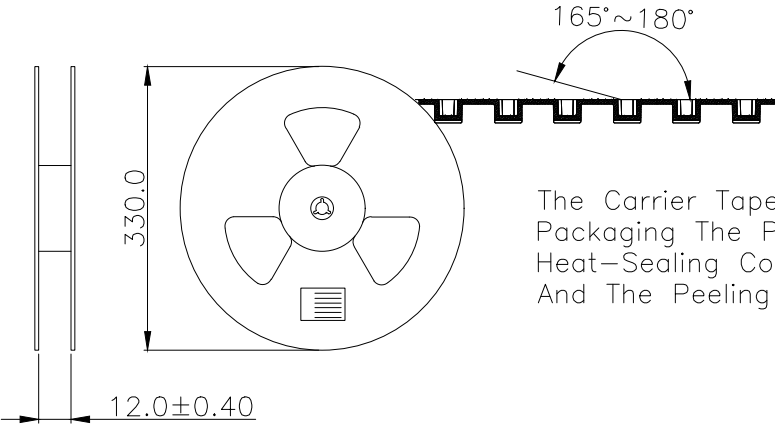

The Carrier Tape Is Heat-Sealed Packaging The Peeling Angle Of The Heat-Sealing Cover Tape Is 165°~180° And The Peeling Force Is 30~120g.

MANUFACTURE DWG		东莞市讯普电子科技有限公司 DongGuan XunPu Electronics Co.,Ltd	
UNLESS OTHERWISE SPECIFIED TOLERANCES		TITLE: 天线弹片 L3.15*W1.00*H1.50	
		PAR	ASP-D1505-B01
DECIMALS:		DWN	Lucas
ANGLES:		CHKD	Ethan
X.:±0.30	X':±2'	APVD	Jacob
X.X:±0.20	X.X':±1'	SCALE:1:1	UNIT:MM
X.XX:±0.15	X.XX':±0.5'	SIZE:A4	SHEET:1F1
CUSTOMER COPY			REV:A