

NOTES:

1:MATERIAL

1-1: SUS-301 THICKNE=0.08MM

2:SPECIFICATIONS

2-1: RATED CURRENT: 1.0A

2-2: VOLTAGE RATING: 1.5V

2-3: CONTACT RESISTANCE: 80mΩ/MAX

2-4: WELDING THRUST: >3KG

2-5: OPERATING TEMPERATURE: -40°C~+85°C

3:DURABILITY: 1500 CYCLES

4:SALT SPRAY TIME: 24H

5:ELECTROPLATE: THE NICKEL-PLATED SUBSTRATE IS 50u" MIN

6:REQUIREMENTS

6-1:TERMINAL TO EAT FULL TIN,NOTPEELING,

WELDING OBVIOUS COLOR AND OTHER ADVERSE

6-2:ROHS.REACH.HF HALOGER ADVERSE OF DOMESTIC

AND INTERNATIONAL ENVIRONMENTAL REQUIREMENTS

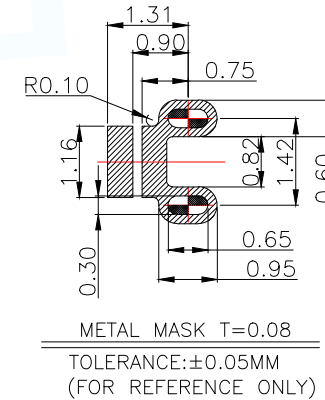
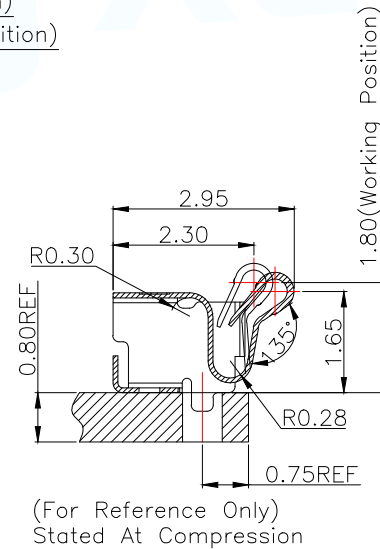
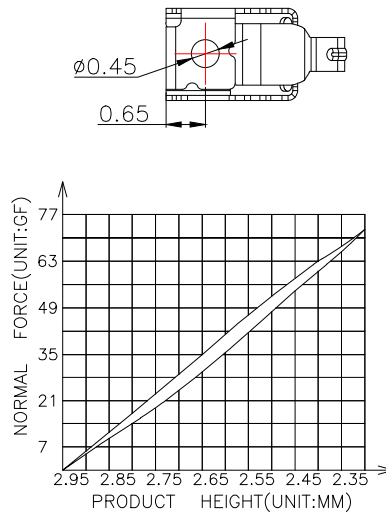
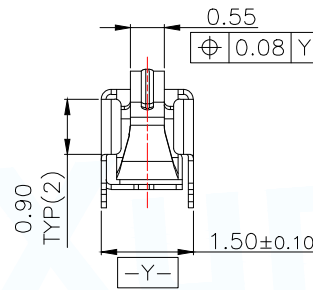
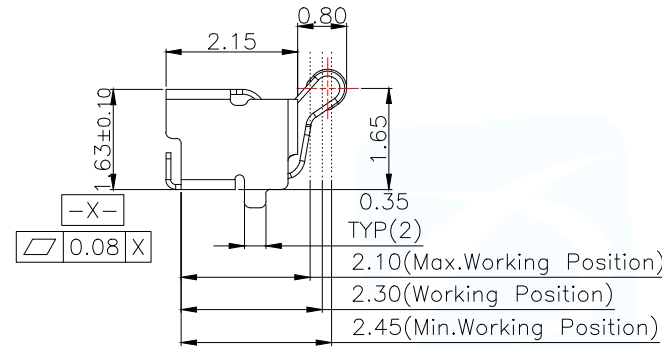

MANUFACTURE DWG		东莞市讯普电子科技有限公司 DongGuan XunPu Electronics Co.,Ltd	
UNLESS OTHERWISE SPECIFIED TOLERANCES		TITLE: ANTENNA SPRING TERMINAL, SMT H=1.60 PAR ASP-D1603-B01	
DECIMALS:	ANGLES:	DWN	Lucas
X.:±0.30	X':±2'	CHKD	Ethan
X.X:±0.20	X.X':±1'	APVD	Jacob
X.XX:±0.15	X.XX':±0.5'	SCALE:1:1	UNIT:MM
CUSTOMER COPY		SIZE:A4	SHEET:1F1
			REV:A

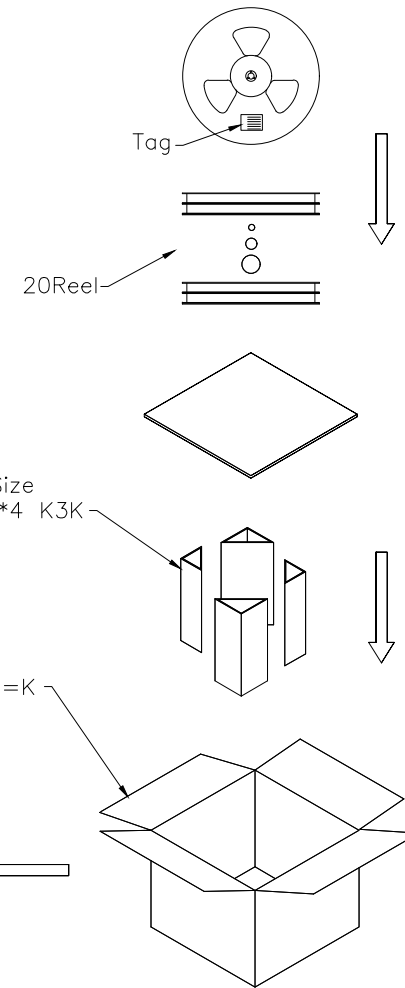
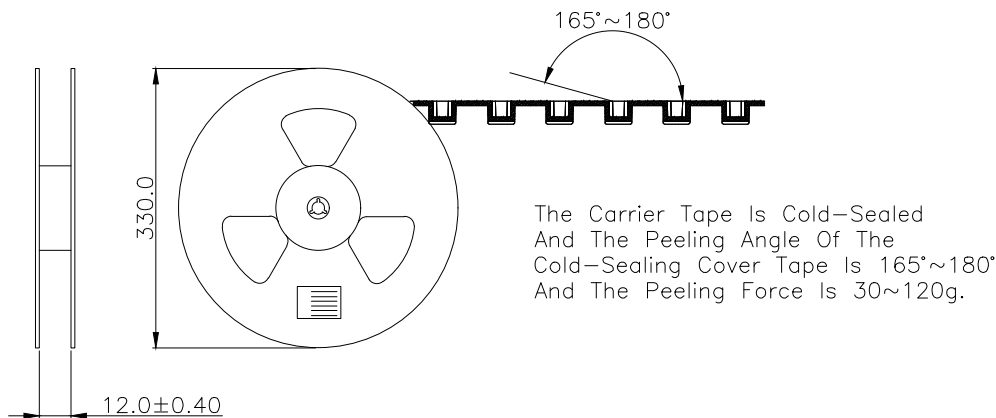
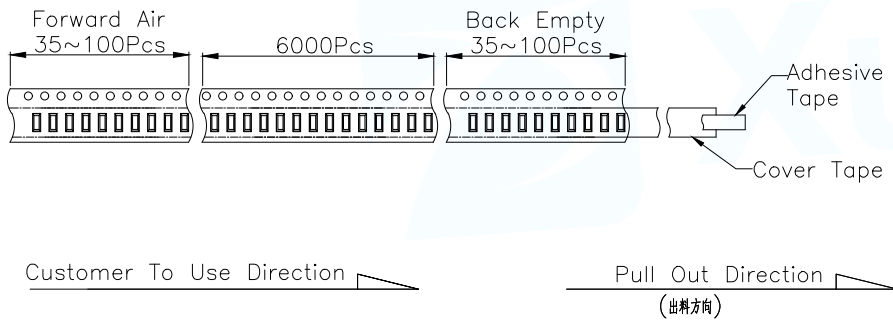
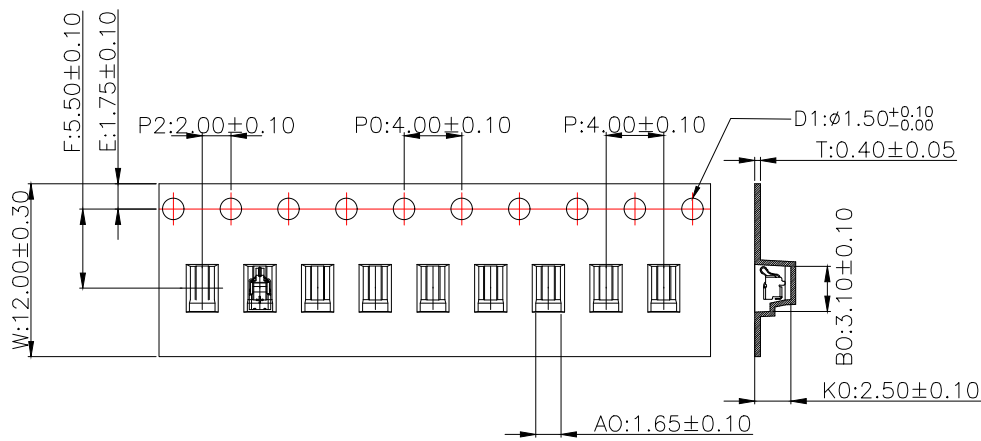

MANUFACTURE DWG		东莞市讯普电子科技有限公司 DongGuan XunPu Electronics Co.,Ltd	
UNLESS OTHERWISE SPECIFIED TOLERANCES		TITLE: ANTENNA SPRING TERMINAL, SMT H=1.60 PAR ASP-D1603-B01	
DECIMALS:	ANGLES:	DWN	Lucas
X.:±0.30	X.:±2°	CHKD	Ethan
X.X:±0.20	X.X':±1°	APVD	Jacob
X.XX:±0.15	X.XX':±0.5°	SCALE:1:1	UNIT:MM
CUSTOMER COPY		SIZE:A4	SHEET:1F1
			REV:A

