

SAMZO REAC/ROHS

REV	ECN NO	DESCRIPTION	DESIGN	APPROVAL	DATE
A1	NEW	Replace frame			2018.06.12

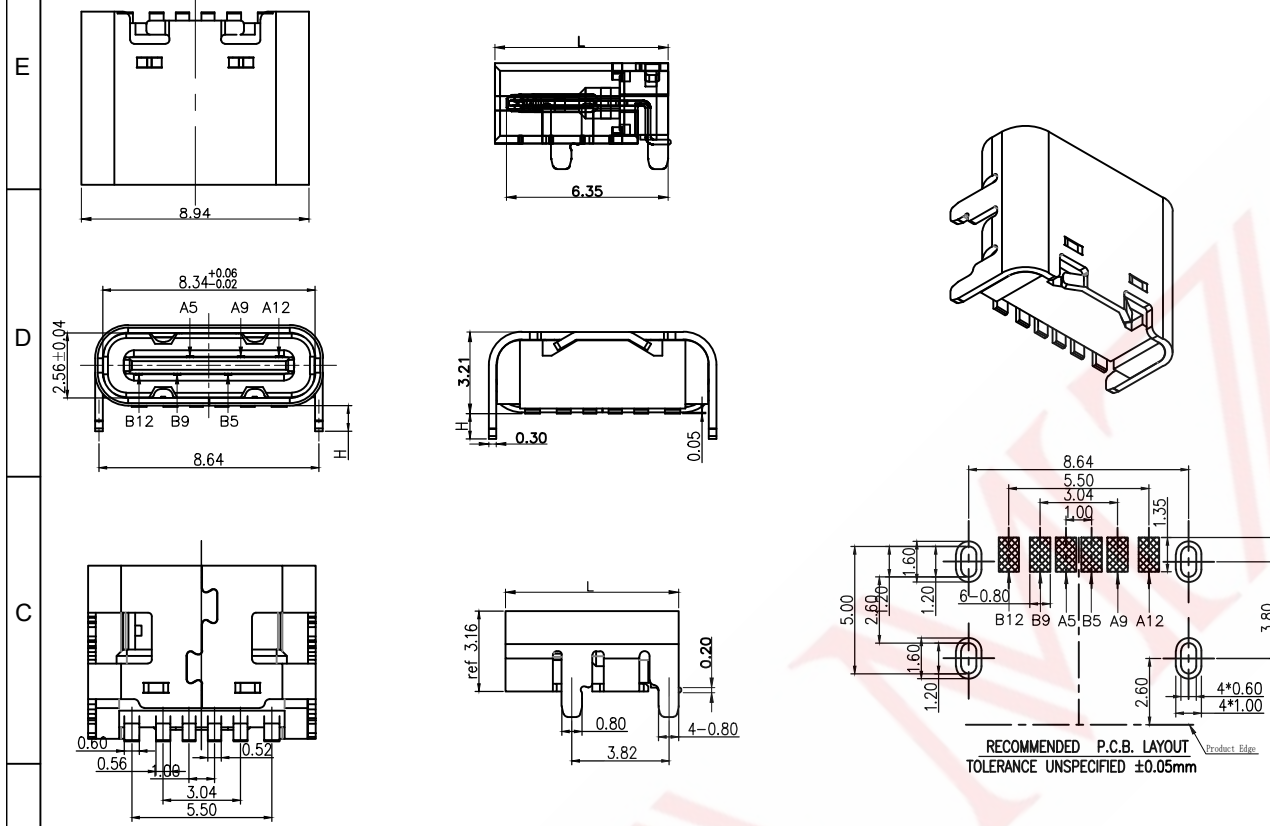

NOTE:

- MATERIAL SPECIFICATION:**
 - 1-1.CONTACTS:COPPER ALLOY
 - 1-2.MID PLATE: 201/301/304 STAINLESS STEEL
 - 1-3.FRONT SHELL: 201/301/304 STAINLESS STEEL
- PLATING SPECIFICATION:**
 - 2-1.CONTACTS:NI 50-120u" MIN. .UNDER PLATED OVER ALL.
 - Au PLATED ON THE FUNCTIONAL AREA OF CONTACT (0.6-30u") .
 - PLATING SPECIFICATIONS OF THE SOLDER AREA FOLLOW THE P/IN
 - 2-2.FRONT SHELL:SEE TABLE1.
 - 2-3.SHIELD PLATE&EMI PLATE:CLEAR ONLY
- MECHANICAL PERFORMANCE,**
 - 3-1.INSERTION FORCE: 0.5~2.0kgf.
 - 3-2.REMOVAL FORCE: 0.8kgf~2.0kgf.
 - 3-3.DURABILITY: 3000/5000/10000 CYCLES.
- ELECTRICAL PERFORMANCE,**
 - 4-1. CURRENT RATING:3.0A
 - VOLTAGE RATING:5.0V
 - 4-2. LLCR:VBUS & GND PINS AND OTHER PINS: 40mΩ/PIN MAX.
 - SHIELD: 50mΩ/MAX.
 - LLCR MAX. CHANGE OF ALL PINS: 10mΩ.
 - 4-3.INSULATION RESISTANCE: 100MΩ MIN
 - 4-4.DIELECTRIC WITHSTAND VOLTAGE,AC 100V FOR 1 MINUTE.
- ENVIRONMENTAL PERFORMANCE:**
 - OPERATING TEMPERATURE: -25°C~+85°C.
- IR REFLOW:**
 - THE PEAK TEMPERATURE ON THE BOARD SHALL BE MAINTAINED FOR 10 SECONDS AT 260°C.

UKDB*TA**
 (A)(B)(C)(D)(E)(F)(G)(H)

A.SERIE: UK-TYPE C
 B.SIZE: D-6pin
 C.MOUNTING: B-WD(pronr)
 D.LOOKS: A-L6.5/B-L6.8mm
 E.STYIE: T:GENERAL
 F.MATERIAL: A-SUS201/B-SUS301/C-SUS304
 G.LIFETIME:A-3000/B-5000/C:10000CYCLES
 H.CODE: B-CUSTOMIZE PALLADIUM PLATING

PIN ASSIGNMENTS

A5	CC1	B12	GND
A9	VBUS	B9	VBUS
A12	GND	B5	CC2
PIN	SIGNAL NAME	PIN	SIGNAL NAME

L	L =6.8	H	H =1.0
L	L =6.5	H	H =0.6

ITEM	DESCRIPTION	MATERIAL	QTY	FINSH/COLOR					FIRST VIEW				
E	塑胶	LCP	1	黑色	GENERAL TOLERANCE								
D	引脚	铜合金	1	镀钯金 1U			≥0~2<	±0.15	SCALE	1:1	UNIT	mm	
C	触点	铜合金	1	镀钯金 1U	DESIGN	WANGUIFA	2018.06.12	≥2~5<	±0.25	SAMZO COMPONENTS Electronic switch and connector manufacturer			
B	中板	SUS201/301/304	1	镀镍 50-120U	CHECKED	ZHENGUILAN	2018.06.12	≥0~2<	±0.15				
A	外壳	SUS201/301/304	1	镀镍 50-120U	APPROVED	LILIANJIANG	2018.06.14	≥5	±0.35				

The copyright belongs to samzo parts [China] Co., Ltd. please use the material after samzo parts agree to authorize. The final right of interpretation belongs to samzo parts.
 WWW.KKK-JP.COM

TITLE::	
TYPE-C 6Pin 6.5/6.8MM 板上型	
DWG NO: UKDB06-P0001	
PART NO: UKDB0610072	
MODEL NO: UKDB-*T**B	
NAME:	
TYPE-C CONN	