

- NOTES
- (1) MATERIAL: C5210 THICKNE=0.10mm
 - (2) PRODUCT SPECIFICATIONS:
 - 2-1: RATED CURRENT: 1.0A
 - 2-2: VOLTAGE RATING: 1.50V
 - 2-3: CONTACT RESISTANCE: 80mΩ/MAX
 - 2-4: WELDING THRUST: ≥3KG
 - 2-5: OPERATING TEMPERATURE: -40°C~+85°C
 - 2-6: DURABILITY: 1500 CYCLES
 - (3) SALT SPRAY: 24 HOURS
 - (4) FINISH: 50u"Min NICKEL UNDERPLATING OVER ALL.
 - (5) REQUIREMENTS
 - 5-1: TERMINAL TO EAT FULL TIN, NOT PEELING WELDING OBVIOUS COLOR AND OTHER ADVERSE
 - 5-2: ROHS, REACH, HF HALOGEN ADVERSE OF DOMESTIC AND INTERNATIONAL ENVIRONMENTAL REQUIREMENTS

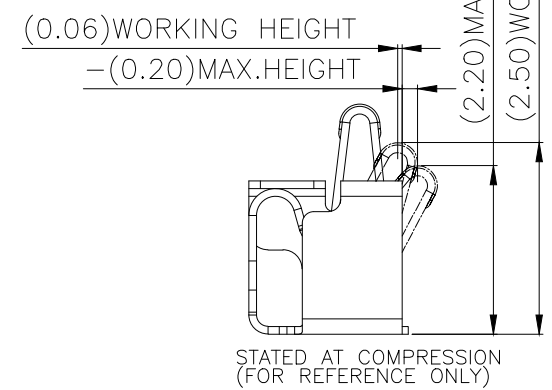

MANUFACTURE DWG		东莞市讯普电子科技有限公司 DongGuan XunPu Electronics Co., Ltd	
UNLESS OTHERWISE SPECIFIED TOLERANCES			TITLE: H3.00 ANTENNA SPRING TERMINAL, SMT T=0.10MM
DECIMALS:	ANGLES:		PAR ASP-D3003-B31
X.: ±0.30	X': ±2°		DWN Lucas
X.X: ±0.20	X.X': ±1°		CHKD Ethan
X.XX: ±0.15	X.XX': ±0.5°	CUSTOMER COPY	APVD Jacob
		SCALE 1:1	UNIT: MM
		SIZE: A4	UNIT: MM
		SHEET: 1F1	REV: A

MAPX	MODIFICATION	DATE	DRAW	APPROVE

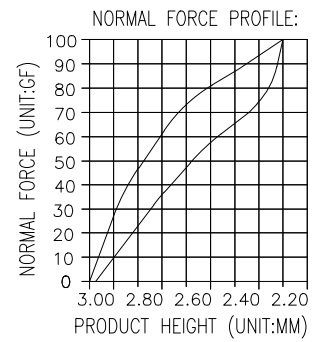
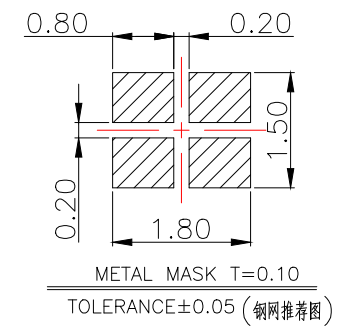
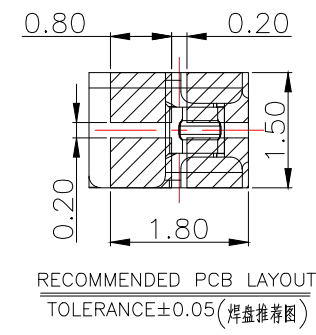
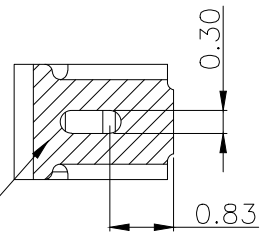
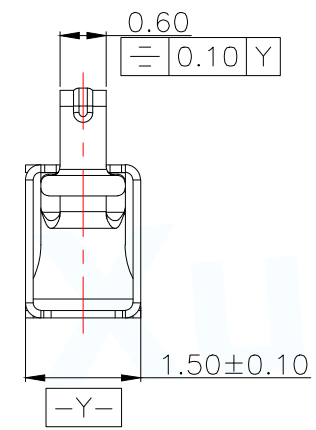
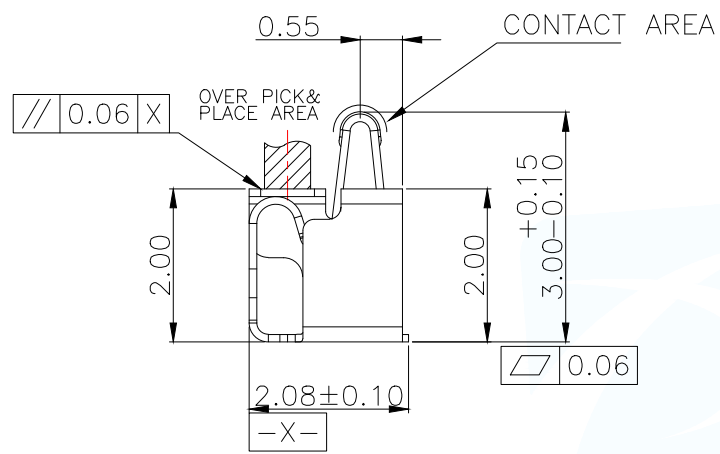
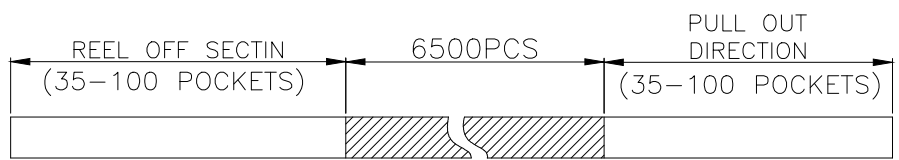

CONN. QTY./REEL	REEL QTY./CARTON	CONN. QTY./CARTON
6500	20	130,000

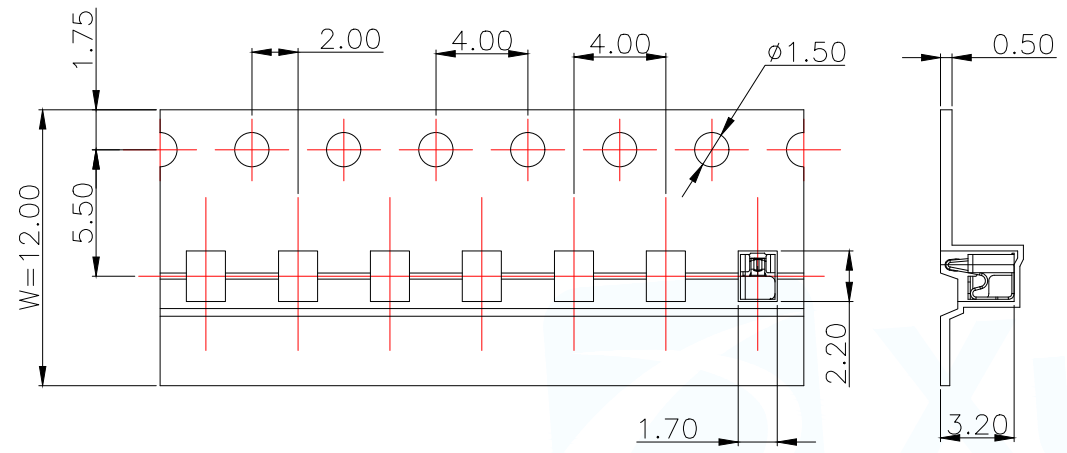

← PRODUCT PACKAGING DIRECTION
 CUSTOMER TO USE DIRECTION →

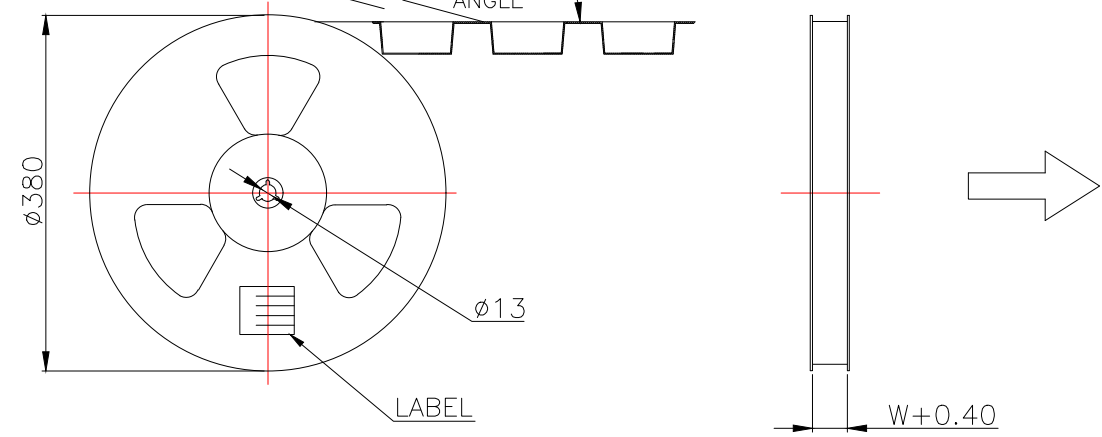
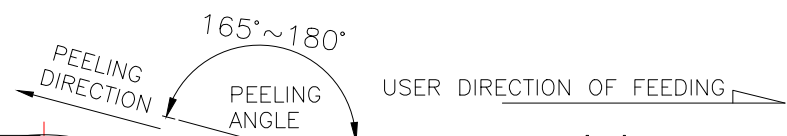

TOTAL 20LAYERS

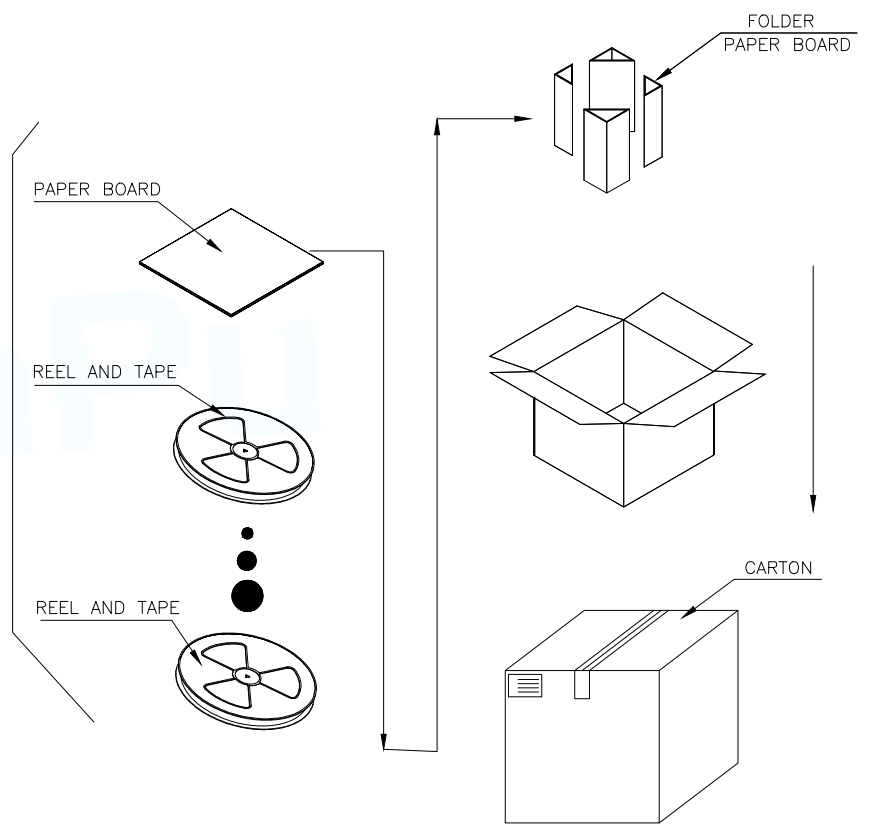

MANUFACTURE DWG		东莞市讯普电子科技有限公司 DongGuan XunPu Electronics Co.,Ltd	
UNLESS OTHERWISE SPECIFIED TOLERANCES			TITLE:H3.00 ANTENNA SPRING TERMINAL,SMT T=0.10MM
DECIMALS:	ANGLES:		PAR ASP-D3003-B31
X.:±0.30	X.':±2'		DWN Lucas
X.X:±0.20	X.X':±1'		CHKD Ethan
X.XX:±0.15	X.XX':±0.5'	CUSTOMER COPY	SCALE:1:1 UNIT:MM
			SIZE:A4 SHEET:1F1 REV:A