



# CD74HC73/HCT73 (LX) Dual JK Flip-Flop with Reset; Negative-Edge Trigger

## Product Specification

### Specification Revision History:

Version	Date	Description
2023-12-A0	2023-12	New
2024-03-A1	2024-03	Modify the parameters



# Contents

<b>1、 General Description.....</b>	<b>1</b>
<b>2、 Block Diagram And Pin Description .....</b>	<b>3</b>
2.1、 Block Diagram .....	3
2.2、 Pin Configurations.....	3
2.3、 Pin Description.....	3
2.4、 Function Table.....	4
<b>3、 Electrical Parameter .....</b>	<b>4</b>
3.1、 Absolute Maximum Ratings.....	4
3.2、 Recommended Operating Conditions.....	4
3.3、 Electrical Characteristics .....	5
3.3.1、 DC Characteristics 1 .....	5
3.3.2、 DC Characteristics 2 .....	6
3.3.3、 AC Characteristics 1 .....	7
3.3.4、 AC Characteristics 2 .....	8
<b>4、 Testing Circuit .....</b>	<b>10</b>
4.1、 AC Testing Circuit .....	10
4.2、 Test Data .....	10
4.3、 AC Testing Waveforms.....	11
4.4、 Measurement Points.....	12
<b>5、 Package Information .....</b>	<b>13</b>
5.1、 DIP14 .....	13
5.2、 SOP14 .....	14
<b>6、 Statements And Notes .....</b>	<b>15</b>
6.1、 The name and content of Hazardous substances or Elements in the product.....	15
6.2、 Notes .....	15



## 1、General Description

The CD74HC/HCT73 is dual negative-edge triggered JK-type flip-flops featuring individual J, K, clock ( $\bar{C}P$ ) and reset ( $\bar{n}R$ ) inputs; also complementary Q and  $\bar{Q}$  outputs.

### Features:

- Supply voltage range:  
CD74HC73: 2V to 6V  
CD74HCT73: 4.5V to 5.5V
- Input levels:  
CD74HC73: CMOS level  
CD74HCT73: TTL level
- Temperature range: -40°C to +125°C
- Packaging information: DIP14/SOP14

### Ordering Information:

#### Tube packing specifications:

Part number	Packaging form	Marking code	Tube quantity	Boxed tube quantity	Boxed quantity	Notes
CD74HC73E(LX)	DIP14	CD74HC73E	25 PCS/tube	40 tube/box	1000 PCS/box	Dimensions of plastic enclosure: 19.0mm×6.4mm Pin spacing: 2.54mm
CD74HCT73E(LX)	DIP14	CD74HCT73E	25 PCS/tube	40 tube/box	1000 PCS/box	Dimensions of plastic enclosure: 19.0mm×6.4mm Pin spacing: 2.54mm
CD74HC73M(LX)	SOP14	HC73M	50 PCS/tube	200 tube/box	10000 PCS/box	Dimensions of plastic enclosure: 8.7mm×3.9mm Pin spacing: 1.27mm
CD74HCT73M(LX)	SOP14	HCT73M	50 PCS/tube	200 tube/box	10000 PCS/box	Dimensions of plastic enclosure: 8.7mm×3.9mm Pin spacing: 1.27mm



**Reel packing specifications:**

Part number	Packaging form	Marking code	Reel quantity	Boxed reel quantity	Notes
CD74HC73M(LX)	SOP14	HC73M	4000 PCS/reel	8000 PCS/box	Dimensions of plastic enclosure: 8.7mm×3.9mm Pin spacing: 1.27mm
CD74HCT73M(LX)	SOP14	HCT73M	4000 PCS/reel	8000 PCS/box	Dimensions of plastic enclosure: 8.7mm×3.9mm Pin spacing: 1.27mm

Note: If the physical information is inconsistent with the ordering information, please refer to the actual product.



## 2、Block Diagram And Pin Description

### 2.1、Block Diagram

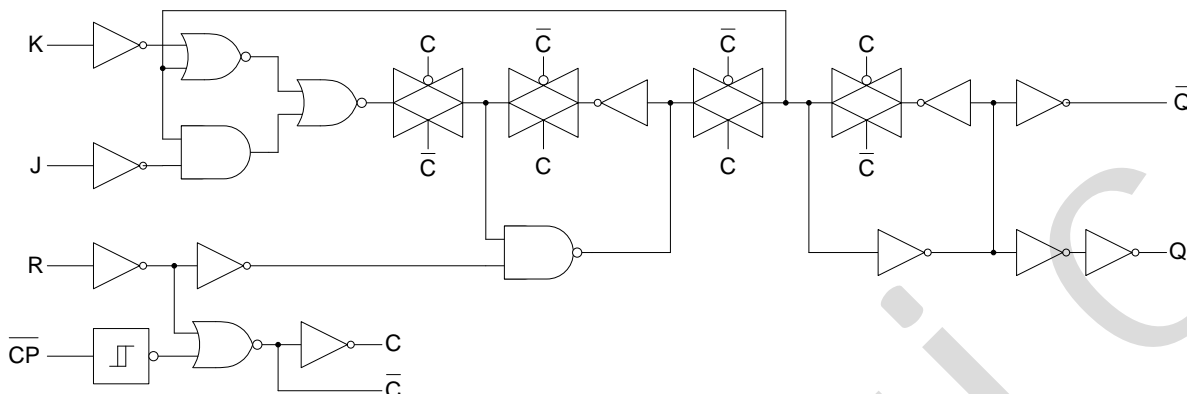

Figure 1. Logic symbol

### 2.2、Pin Configurations

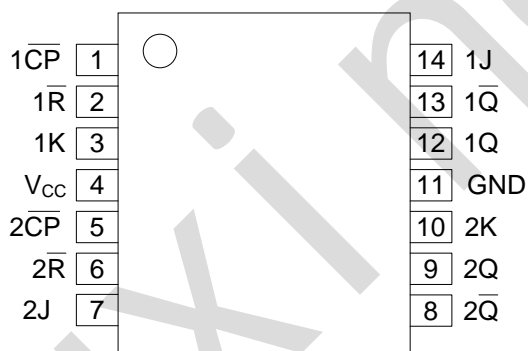

Figure 2. Pin Configurations

### 2.3、Pin Description

Pin No.	Pin Name	Description
1	1CP	clock input (HIGH-to-LOW edge-triggered)
2	1R	asynchronous reset input (active LOW)
3	1K	synchronous K input
4	V <sub>CC</sub>	supply voltage
5	2CP	clock input (HIGH-to-LOW edge-triggered)
6	2R	asynchronous reset input (active LOW)
7	2J	synchronous J input
8	2Q	complement output
9	2Q	true output
10	2K	synchronous K input
11	GND	ground (0V)
12	1Q	true output
13	1Q	complement output
14	1J	synchronous J input



## 2.4、Function Table

Input				Output		Operating mode
$\overline{nR}$	$\overline{nCP}$	$nJ$	$nK$	$nQ$	$\overline{nQ}$	
L	X	X	X	L	H	asynchronous reset
H	↓	h	h	$\overline{q}$	q	toggle
H	↓	l	h	L	H	load 0 (reset)
H	↓	h	l	H	L	load 1 (set)
H	↓	l	l	q	$\overline{q}$	hold (no change)

Notes:

H = HIGH voltage level;

h = HIGH voltage level one set-up time prior to the HIGH-to-LOW clock transition;

L = LOW voltage level;

l = LOW voltage level one set-up time prior to the HIGH-to-LOW clock transition;

q = state of referenced output one set-up time prior to the HIGH-to-LOW clock transition;

X = don't care;

↓ = HIGH-to-LOW clock transition.

## 3、Electrical Parameter

### 3.1、Absolute Maximum Ratings

(Voltages are referenced to GND (ground=0V), unless otherwise specified.)

Parameter	Symbol	Conditions	Min.	Max.	Unit
supply voltage	$V_{CC}$	-	-0.5	+7	V
supply current	$I_{CC}$	-	-	50	mA
ground current	$I_{GND}$	-	-50	-	mA
input clamping current	$I_{IK}$	$V_I < -0.5V$ or $V_I > V_{CC}+0.5V$	-	±20	mA
output clamping current	$I_{OK}$	$V_O < -0.5V$ or $V_O > V_{CC}+0.5V$	-	±20	mA
output current	$I_O$	$-0.5V < V_O < V_{CC}+0.5V$	-	±25	mA
storage temperature	$T_{stg}$	-	-65	+150	°C
soldering temperature	$T_L$	10s	DIP		°C
			SOP/TSSOP		
			245		
			260		

### 3.2、Recommended Operating Conditions

Parameter	Symbol	Conditions	Min.	Typ.	Max.	Unit
<b>CD74HC73</b>						
supply voltage	$V_{CC}$	-	2.0	5.0	6.0	V
input voltage	$V_I$	-	0	-	$V_{CC}$	V
output voltage	$V_O$	-	0	-	$V_{CC}$	V
ambient temperature	$T_{amb}$	-	-40	-	+125	°C
<b>CD74HCT73</b>						
supply voltage	$V_{CC}$	-	4.5	5.0	5.5	V
input voltage	$V_I$	-	0	-	$V_{CC}$	V
output voltage	$V_O$	-	0	-	$V_{CC}$	V
ambient temperature	$T_{amb}$	-	-40	-	+125	°C



### 3.3、Electrical Characteristics

#### 3.3.1、DC Characteristics 1

( $T_{amb} = -40^{\circ}\text{C}$  to  $+85^{\circ}\text{C}$ , voltages are referenced to GND (ground=0V), unless otherwise specified.)

Parameter	Symbol	V <sub>CC</sub>	Conditions	Min.	Typ.	Max.	Unit
<b>CD74HC73</b>							
HIGH-level input voltage	V <sub>IH</sub>	2.0V	-	1.5	1.2	-	V
		4.5V	-	3.15	2.4	-	V
		6.0V	-	4.2	3.2	-	V
LOW-level input voltage	V <sub>IL</sub>	2.0V	-	-	0.8	0.5	V
		4.5V	-	-	2.1	1.35	V
		6.0V	-	-	2.8	1.8	V
HIGH-level output voltage	V <sub>OH</sub>	2.0V	I <sub>O</sub> =-20uA	1.9	2.0	-	V
		4.5V	I <sub>O</sub> =-20uA	4.4	4.5	-	V
		6.0V	I <sub>O</sub> =-20uA	5.9	6.0	-	V
		4.5V	I <sub>O</sub> =-4.0mA	3.84	4.32	-	V
		6.0V	I <sub>O</sub> =-5.2mA	5.34	5.81	-	V
LOW-level output voltage	V <sub>OL</sub>	2.0V	I <sub>O</sub> =20uA	-	0	0.1	V
		4.5V	I <sub>O</sub> =20uA	-	0	0.1	V
		6.0V	I <sub>O</sub> =20uA	-	0	0.1	V
		4.5V	I <sub>O</sub> =4.0mA	-	0.15	0.33	V
		6.0V	I <sub>O</sub> =5.2mA	-	0.16	0.33	V
input leakage current	I <sub>I</sub>	6.0V	V <sub>I</sub> =V <sub>CC</sub> or GND	-	-	±1	uA
supply current	I <sub>CC</sub>	6.0V	V <sub>I</sub> =V <sub>CC</sub> or GND; I <sub>O</sub> =0A	-	-	80	uA
<b>CD74HCT73</b>							
HIGH-level input voltage	V <sub>IH</sub>	4.5~5.5V	-	2.0	1.6	-	V
LOW-level input voltage	V <sub>IL</sub>	4.5~5.5V	-	-	1.2	0.8	V
HIGH-level output voltage	V <sub>OH</sub>	4.5V	I <sub>O</sub> =-20uA	4.4	4.5	-	V
			I <sub>O</sub> =-4.0mA	3.84	4.32	-	V
LOW-level output voltage	V <sub>OL</sub>	4.5V	I <sub>O</sub> =20uA	-	0	0.1	V
			I <sub>O</sub> =4.0mA	-	0.15	0.33	V
input leakage current	I <sub>I</sub>	5.5V	V <sub>I</sub> =V <sub>CC</sub> or GND	-	-	±1	uA
supply current	I <sub>CC</sub>	5.5V	V <sub>I</sub> =V <sub>CC</sub> or GND; I <sub>O</sub> =0A	-	-	80	uA
additional supply current	ΔI <sub>CC</sub>	4.5~5.5V	One input at V <sub>I</sub> =V <sub>CC</sub> -2.1V; Other inputs at V <sub>CC</sub> or GND; I <sub>O</sub> =0A	-	-	135	uA



### 3.3.2、DC Characteristics 2

( $T_{amb} = -40^{\circ}\text{C}$  to  $+125^{\circ}\text{C}$ , voltages are referenced to GND (ground=0V), unless otherwise specified.)

Parameter	Symbol	V <sub>CC</sub>	Conditions	Min.	Typ.	Max.	Unit
<b>CD74HC73</b>							
HIGH-level input voltage	V <sub>IH</sub>	2.0V	-	1.5	-	-	V
		4.5V	-	3.15	-	-	V
		6.0V	-	4.2	-	-	V
LOW-level input voltage	V <sub>IL</sub>	2.0V	-	-	-	0.5	V
		4.5V	-	-	-	1.35	V
		6.0V	-	-	-	1.8	V
HIGH-level output voltage	V <sub>OH</sub>	2.0V	I <sub>O</sub> =-20uA	1.9	-	-	V
		4.5V	I <sub>O</sub> =-20uA	4.4	-	-	V
		6.0V	I <sub>O</sub> =-20uA	5.9	-	-	V
		4.5V	I <sub>O</sub> =-4.0mA	3.7	-	-	V
		6.0V	I <sub>O</sub> =-5.2mA	5.2	-	-	V
LOW-level output voltage	V <sub>OL</sub>	2.0V	I <sub>O</sub> =20uA	-	-	0.1	V
		4.5V	I <sub>O</sub> =20uA	-	-	0.1	V
		6.0V	I <sub>O</sub> =20uA	-	-	0.1	V
		4.5V	I <sub>O</sub> =4.0mA	-	-	0.4	V
		6.0V	I <sub>O</sub> =5.2mA	-	-	0.4	V
input leakage current	I <sub>I</sub>	6.0V	V <sub>I</sub> =V <sub>CC</sub> or GND	-	-	±1	uA
supply current	I <sub>CC</sub>	6.0V	V <sub>I</sub> =V <sub>CC</sub> or GND; I <sub>O</sub> =0A	-	-	160	uA
<b>CD74HCT73</b>							
HIGH-level input voltage	V <sub>IH</sub>	4.5~5.5V	-	2.0	-	-	V
LOW-level input voltage	V <sub>IL</sub>	4.5~5.5V	-	-	-	0.8	V
HIGH-level output voltage	V <sub>OH</sub>	4.5V	I <sub>O</sub> =-20uA	4.4	-	-	V
			I <sub>O</sub> =-4.0mA	3.7	-	-	V
LOW-level output voltage	V <sub>OL</sub>	4.5V	I <sub>O</sub> =20uA	-	-	0.1	V
			I <sub>O</sub> =4.0mA	-	-	0.4	V
input leakage current	I <sub>I</sub>	5.5V	V <sub>I</sub> =V <sub>CC</sub> or GND	-	-	±1	uA
supply current	I <sub>CC</sub>	5.5V	V <sub>I</sub> =V <sub>CC</sub> or GND; I <sub>O</sub> =0A	-	-	160	uA
additional supply current	ΔI <sub>CC</sub>	4.5~5.5V	One input at V <sub>I</sub> =V <sub>CC</sub> -2.1V; Other inputs at V <sub>CC</sub> or GND; I <sub>O</sub> =0A	-	-	147	uA





### 3.3.3、AC Characteristics 1

( $T_{amb} = -40^{\circ}\text{C}$  to  $+85^{\circ}\text{C}$ , voltages are referenced to GND (ground=0V), unless otherwise specified.)

Parameter	Symbol	V <sub>CC</sub>	Conditions	Min.	Typ.	Max.	Unit		
<b>CD74HC73</b>									
nCP to nQ propagation delay	t <sub>PLH</sub> , t <sub>PHL</sub>	2.0V	C <sub>L</sub> =50pF	see Figure 4	-	52	160	ns	
		4.5V	C <sub>L</sub> =50pF		-	19	32	ns	
		5.0V	C <sub>L</sub> =15pF		-	16	-	ns	
		6.0V	C <sub>L</sub> =50pF		-	15	27	ns	
nCP to nQ propagation delay		2.0V	C <sub>L</sub> =50pF	see Figure 4	-	52	200	ns	
		4.5V	C <sub>L</sub> =50pF		-	19	40	ns	
		5.0V	C <sub>L</sub> =15pF		-	16	-	ns	
		6.0V	C <sub>L</sub> =50pF		-	15	34	ns	
nR to nQ/nQ propagation delay		t <sub>THL</sub> , t <sub>TLH</sub>	2.0V	C <sub>L</sub> =50pF	see Figure 5	-	52	195	ns
			4.5V	C <sub>L</sub> =50pF		-	19	39	ns
			5.0V	C <sub>L</sub> =15pF		-	16	-	ns
			6.0V	C <sub>L</sub> =50pF		-	15	26	ns
nQ/nQ transition time	2.0V		C <sub>L</sub> =50pF	see Figure 4	-	19	95	ns	
	4.5V		C <sub>L</sub> =50pF		-	7	19	ns	
	6.0V		C <sub>L</sub> =50pF		-	6	16	ns	
nCP input HIGH or LOW pulse width	tw		2.0V	C <sub>L</sub> =50pF	see Figure 4	100	22	-	ns
		4.5V	C <sub>L</sub> =50pF	20		8	-	ns	
		6.0V	C <sub>L</sub> =50pF	17		6	-	ns	
nR input, HIGH pulse width		2.0V	C <sub>L</sub> =50pF	see Figure 5	100	22	-	ns	
		4.5V	C <sub>L</sub> =50pF		20	8	-	ns	
		6.0V	C <sub>L</sub> =50pF		17	6	-	ns	
nR to nCP recovery time	trec	2.0V	C <sub>L</sub> =50pF	see Figure 5	75	19	-	ns	
		4.5V	C <sub>L</sub> =50pF		15	7	-	ns	
		6.0V	C <sub>L</sub> =50pF		13	6	-	ns	
nJ,nK to nCP set-up time	tsu	2.0V	C <sub>L</sub> =50pF	see Figure 4	125	22	-	ns	
		4.5V	C <sub>L</sub> =50pF		25	8	-	ns	
		6.0V	C <sub>L</sub> =50pF		21	6	-	ns	
nJ,nK to nCP hold time	th	2.0V	C <sub>L</sub> =50pF	see Figure 4	3	-6	-	ns	
		4.5V	C <sub>L</sub> =50pF		3	-2	-	ns	
		6.0V	C <sub>L</sub> =50pF		3	-2	-	ns	
maximum clock frequency	fmax	2.0V	C <sub>L</sub> =50pF	see Figure 4	4.8	30	-	MHz	
		4.5V	C <sub>L</sub> =50pF		24	91	-	MHz	
		6.0V	C <sub>L</sub> =50pF		28	108	-	MHz	
<b>CD74HCT73</b>									
nCP to nQ propagation delay	t <sub>PLH</sub> , t <sub>PHL</sub>	4.5V	C <sub>L</sub> =50pF	see Figure 4	-	19	45	ns	
		5.0V	C <sub>L</sub> =15pF		-	16	-	ns	
nCP to nQ propagation delay		4.5V	C <sub>L</sub> =50pF	see Figure 4	-	21	45	ns	
		5.0V	C <sub>L</sub> =15pF		-	18	-	ns	
nR to nQ/nQ		4.5V	C <sub>L</sub> =50pF	see Figure 5	-	20	48	ns	



propagation delay		5.0V	$C_L=15\text{pF}$			17	-	ns
transition time	$t_{\text{THL}}, t_{\text{TLH}}$	4.5V	$C_L=50\text{pF}$	see Figure 4	-	7	15	ns
nCP HIGH or LOW pulse width	tw	4.5V	$C_L=50\text{pF}$	see Figure 4	20	9	-	ns
nR HIGH pulse width		4.5V	$C_L=50\text{pF}$	see Figure 5	25	11	-	ns
nR to nCP recovery time	trec	4.5V	$C_L=50\text{pF}$	see Figure 5	18	8	-	ns
nJ/nQ to nCP set-up time	tsu	4.5V	$C_L=50\text{pF}$	see Figure 4	25	7	-	ns
nJ/nQ to nCP hold time	th	4.5V	$C_L=50\text{pF}$	see Figure 4	5	-2	-	ns
maximum clock frequency	fmax	4.5V	$C_L=50\text{pF}$	see Figure 4	24	66	-	MHz

### 3.3.4、AC Characteristics 2

( $T_{\text{amb}}=-40^{\circ}\text{C}$  to  $+125^{\circ}\text{C}$ , voltages are referenced to GND (ground=0V), unless otherwise specified.)

Parameter	Symbol	$V_{\text{CC}}$	Conditions	Min.	Typ.	Max.	Unit	
<b>CD74HC73</b>								
nCP to nQ propagation delay	$t_{\text{PLH}}, t_{\text{PHL}}$	2.0V	$C_L=50\text{pF}$	see Figure 4	-	-	240	ns
		4.5V	$C_L=50\text{pF}$		-	-	48	ns
		6.0V	$C_L=50\text{pF}$		-	-	41	ns
nCP to nQ propagation delay		2.0V	$C_L=50\text{pF}$	see Figure 4	-	-	240	ns
		4.5V	$C_L=50\text{pF}$		-	-	48	ns
		6.0V	$C_L=50\text{pF}$		-	-	41	ns
nR to nQ/nQ propagation delay		2.0V	$C_L=50\text{pF}$	see Figure 5	-	-	235	ns
		4.5V	$C_L=50\text{pF}$		-	-	47	ns
		6.0V	$C_L=50\text{pF}$		-	-	40	ns
nQ/nQ transition time	2.0V	$C_L=50\text{pF}$	see Figure 4	-	-	110	ns	
	4.5V	$C_L=50\text{pF}$		-	-	22	ns	
	6.0V	$C_L=50\text{pF}$		-	-	19	ns	
nCP input HIGH or LOW pulse width	tw	2.0V	$C_L=50\text{pF}$	see Figure 4	120	-	-	ns
		4.5V	$C_L=50\text{pF}$		24	-	-	ns
		6.0V	$C_L=50\text{pF}$		20	-	-	ns
nR input, HIGH pulse width		2.0V	$C_L=50\text{pF}$	see Figure 5	120	-	-	ns
		4.5V	$C_L=50\text{pF}$		24	-	-	ns
		6.0V	$C_L=50\text{pF}$		20	-	-	ns
nR to nCP recovery time		2.0V	$C_L=50\text{pF}$	see Figure 5	90	-	-	ns
		4.5V	$C_L=50\text{pF}$		18	-	-	ns
		6.0V	$C_L=50\text{pF}$		15	-	-	ns
nJ,nK to nCP set-up time	tsu	2.0V	$C_L=50\text{pF}$	see Figure 4	150	-	-	ns
		4.5V	$C_L=50\text{pF}$		30	-	-	ns



		6.0V	$C_L=50\text{pF}$		26	-	-	ns
nJ,nK to nCP hold time	th	2.0V	$C_L=50\text{pF}$	see Figure 4	3	-	-	ns
		4.5V	$C_L=50\text{pF}$		3	-	-	ns
		6.0V	$C_L=50\text{pF}$		3	-	-	ns
maximum clock frequency	fmax	2.0V	$C_L=50\text{pF}$	see Figure 4	4.0	-	-	MHz
		4.5V	$C_L=50\text{pF}$		20	-	-	MHz
		6.0V	$C_L=50\text{pF}$		24	-	-	MHz
<b>CD74HCT73</b>								
nCP to nQ propagation delay	$t_{PLH}, t_{PHL}$	4.5V	$C_L=50\text{pF}$	see Figure 4	-	-	54	ns
nCP to nQ propagation delay		4.5V	$C_L=50\text{pF}$		-	-	54	ns
nR to nQ/nQ propagation delay		4.5V	$C_L=50\text{pF}$	see Figure 5	-	-	57	ns
transition time	$t_{THL}, t_{TLH}$	4.5V	$C_L=50\text{pF}$	see Figure 4	-	-	22	ns
nCP HIGH or LOW pulse width	tw	4.5V	$C_L=50\text{pF}$	see Figure 4	24	-	-	ns
nR HIGH pulse width		4.5V	$C_L=50\text{pF}$	see Figure 5	30	-	-	ns
nR to nCP recovery time	trec	4.5V	$C_L=50\text{pF}$	see Figure 5	21	-	-	ns
nJ/nQ to nCP set-up time	tsu	4.5V	$C_L=50\text{pF}$	see Figure 4	30	-	-	ns
nJ/nQ to nCP hold time	th	4.5V	$C_L=50\text{pF}$	see Figure 4	5	-	-	ns
maximum clock frequency	fmax	4.5V	$C_L=50\text{pF}$	see Figure 4	20	-	-	MHz

## 4、Testing Circuit

### 4.1、AC Testing Circuit

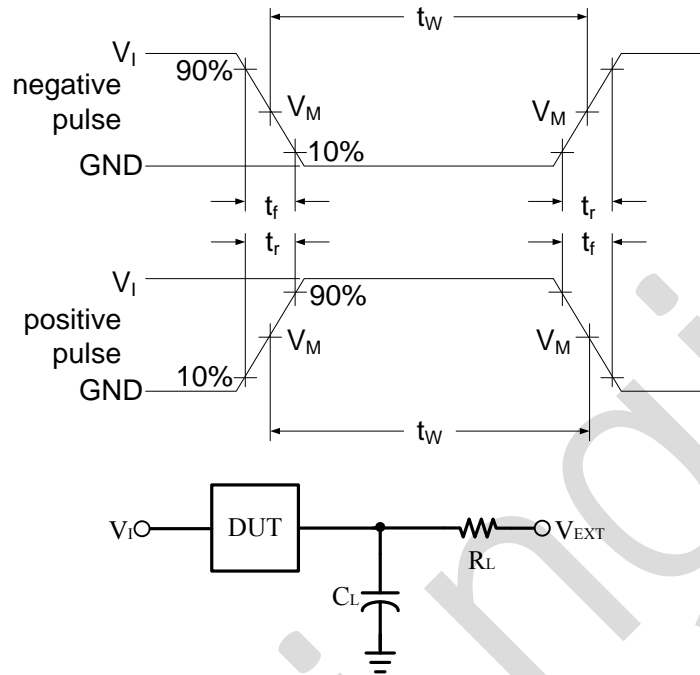

Figure 3. Test circuit for measuring switching times

$C_L$  includes probe and jig capacitance.

### 4.2、Test Data

Type	Input		Load		$V_{EXT}$		
	$V_I$	$t_r = t_f$	$C_L$	$R_L$	$t_{PLH}/t_{PHL}$	$t_{PLZ}/t_{PZL}$	$t_{PHZ}/t_{PZH}$
CD74HC73	$V_{CC}$	3.0ns	15pF, 50pF	1K $\Omega$	Open	$V_{CC}$	GND
CD74HCT73	3.0V	3.0ns	15pF, 50pF	1K $\Omega$	Open	$V_{CC}$	GND



### 4.3、AC Testing Waveforms

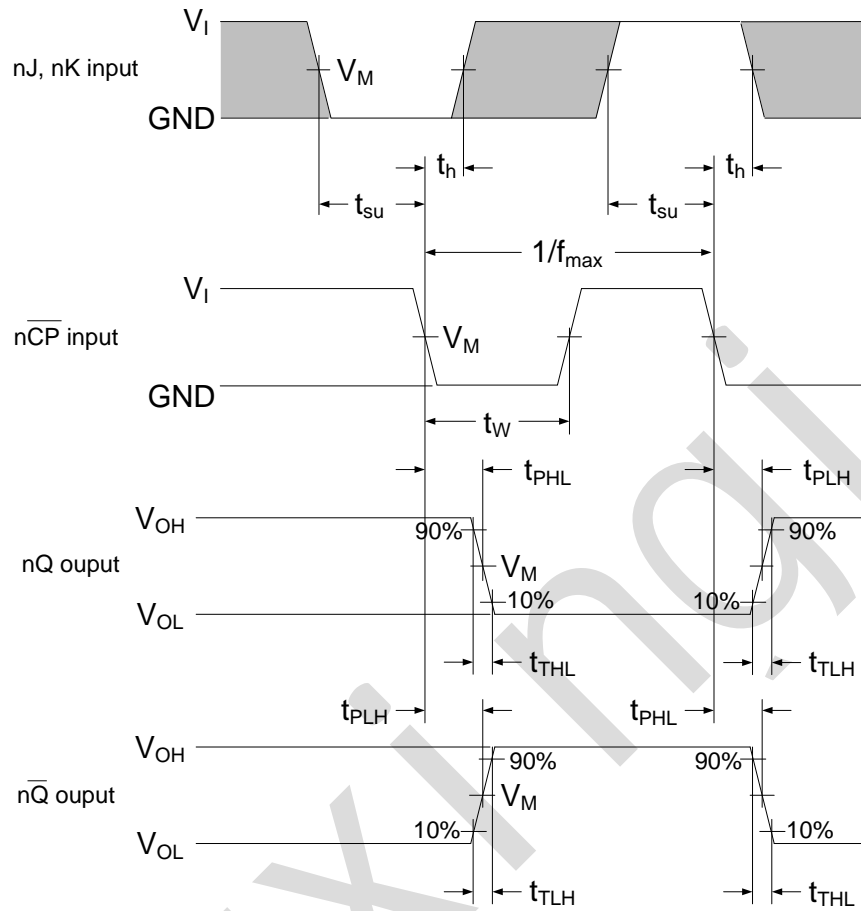

Figure 4. Clock propagation delays, pulse width, set-up and hold times, output transition times and the maximum frequency

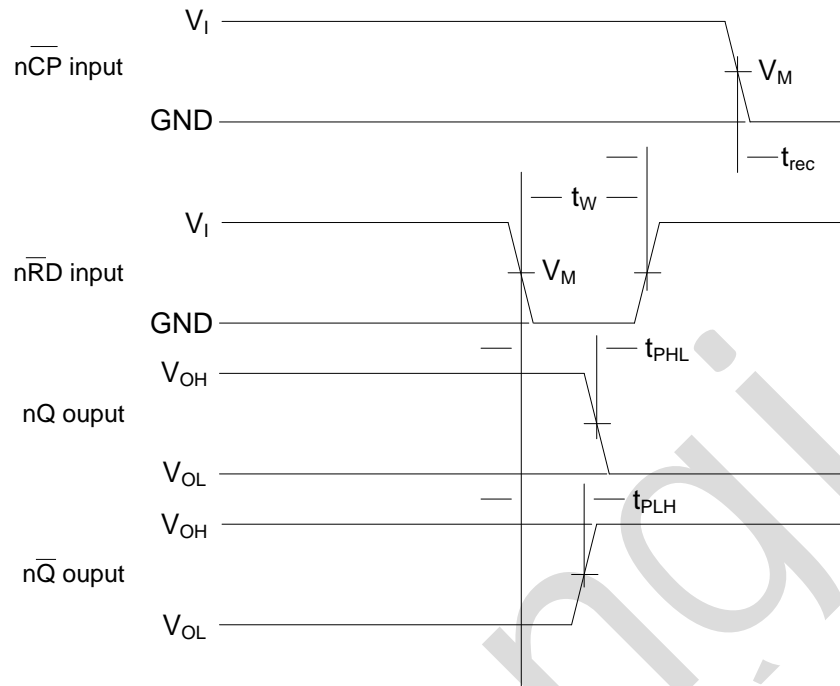

Figure 5. Reset propagation delays, pulse width and recovery time

#### 4.4. Measurement Points

Type	Input	Output
	$V_M$	$V_M$
CD74HC73	$0.5 \times V_{CC}$	$0.5 \times V_{CC}$
CD74HCT73	1.3V	1.3V



## 5、Package Information

### 5.1、DIP14

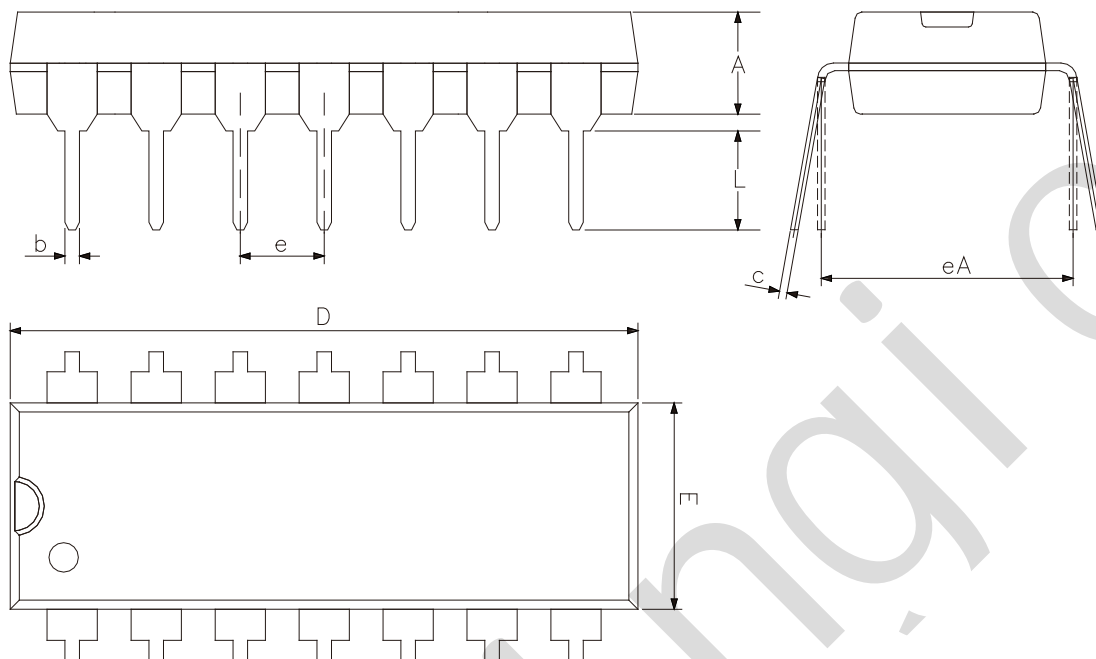

2023/12/A	Dimensions In Millimeters	
Symbol	Min	Max
A	3.05	3.60
b	0.33	0.56
c	0.20	0.36
D	18.80	19.40
E	6.20	6.60
e	2.54	
eA	7.62	10.90
L	2.92	—



## 5.2、SOP14

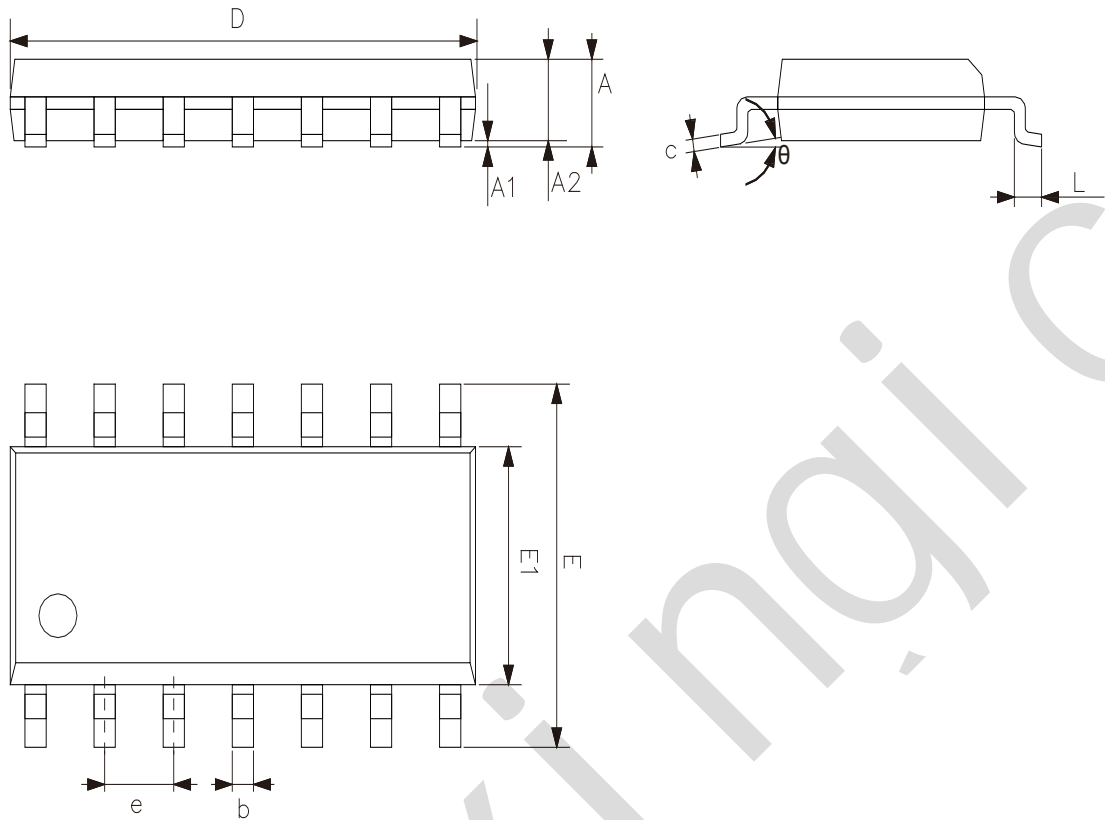

2023/12/A	Dimensions In Millimeters	
Symbol	Min.	Max.
A	1.50	1.75
A1	0.05	0.25
A2	1.30	—
b	0.33	0.50
c	0.19	0.25
D	8.43	8.76
E	5.80	6.25
E1	3.75	4.00
e	1.27	
L	0.40	0.89
$\theta$	0°	8°





## 6、 Statements And Notes

### 6.1、 The name and content of Hazardous substances or Elements in the product

Part name	Hazardous substances or Elements									
	Lead and lead compounds	Mercury and mercury compounds	Cadmium and cadmium compounds	Hexavalent chromium compounds	Polybrominated biphenyls	Polybrominated biphenyl ethers	Dibutyl phthalate	Butylbenzyl phthalate	Di-2-ethylhexyl phthalate	Diisobutyl phthalate
Lead frame	○	○	○	○	○	○	○	○	○	○
Plastic resin	○	○	○	○	○	○	○	○	○	○
Chip	○	○	○	○	○	○	○	○	○	○
The lead	○	○	○	○	○	○	○	○	○	○
Plastic sheet installed	○	○	○	○	○	○	○	○	○	○
explanation	○: Indicates that the content of hazardous substances or elements in the detection limit of the following the SJ/T11363-2006 standard. ×: Indicates that the content of hazardous substances or elements exceeding the SJ/T11363-2006 Standard limit requirements.									

### 6.2、 Notes

We recommend you to read this chapter carefully before using this product.

The information in this chapter is provided for reference only and Lingxing disclaims any express or implied warranties, including but not limited to applicability, special application or non-infringement of third party rights.

This product is not suitable for critical equipment such as life-saving, life-sustaining or safety equipment. It is also not suitable for applications that may result in personal injury, death, or serious property or environmental damage due to product malfunction or failure. Lingxing will not be liable for any damages incurred by the customers at their own risk for such applications.

The customer is responsible for conducting all necessary tests Lingxing's application to avoid failure in the application or the application of the customer's third party users. Lingxing does not accept any liability.

The Company reserves the right to change or improve the information published in this chapter at any time. The information in this chapter are subject to change without notice. We recommend the customer to consult our sales staff before purchasing.

Please obtain related materials form Lingxing's regular channels and we are not responsible for its content if it is provided by sources other than our company.

In case of any conflict between the Chinese and English version, the version is subject to the Chinese one.