

### FEATURES

- \* Low forward voltage drop
- \* High current capability
- \* High reliability
- \* High surge current capability
- \* Epitaxial construction

### MECHANICAL DATA

- \* Case: Molded plastic
- \* Epoxy: UL 94V-0 rate flame retardant
- \* Lead: Lead solderable per MIL-STD-202, method 208 guaranteed
- \* Polarity: As Marked
- \* Mounting position: Any
- \* Weight: 2.24 grams

### VOLTAGE RANGE

45 to 200 Volts

### CURRENT

10 Ampere



### TO-252

Unit: mm

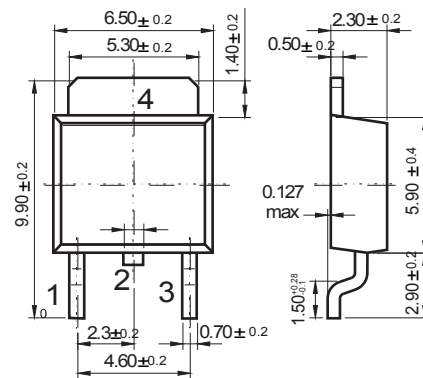

Dimensions in inches and (millimeters)

## MAXIMUM RATINGS AND ELECTRICAL CHARACTERISTICS

Rating 25°C ambient temperature unless otherwise specified.  
Single phase half wave, 60Hz, resistive or inductive load.  
For capacitive load, derate current by 20%.

TYPE NUMBER	MBRD 1045CT	MBRD 1060CT	MBRD 10100CT	MBRD 10150CT	MBRD 10200CT	UNITS
Maximum Recurrent Peak Reverse Voltage	45	60	100	150	200	V
Maximum RMS Voltage	32	42	70	105	140	V
Maximum DC Blocking Voltage	45	60	100	150	200	V
Maximum Average Forward Rectified Current .375"(9.5mm) Lead Length at Tc=100°C	10					A
Peak Forward Surge Current, 8.3 ms single half sine-wave superimposed on rated load (JEDEC method)	150					A
Maximum Instantaneous Forward Voltage at 10A	0.60	0.75	0.85	0.90		V
Maximum DC Reverse Current at Rated DC Blocking Voltage	0.1		0.02			mA
	5		2			mA
Typical Junction Capacitance (Note1)	400					pF
Typical Thermal Resistance R <sub>JA</sub> (Note 2)	8					°C/W
Operating Temperature Range T <sub>J</sub>	-55 — +150					°C
Storage Temperature Range T <sub>STG</sub>	-55 — +150					°C

#### NOTES:

1. Measured at 1MHz and applied reverse voltage of 4.0V D.C.
2. Thermal Resistance Junction to Ambient Vertical PC Board Mounting 0.5"(12.7mm) Lead Length.

## RATING AND CHARACTERISTIC CURVES (MBRD1045CT THRU MBRD10200CT)

FIG.1-TYPICAL FORWARD CURRENT DERATING CURVE

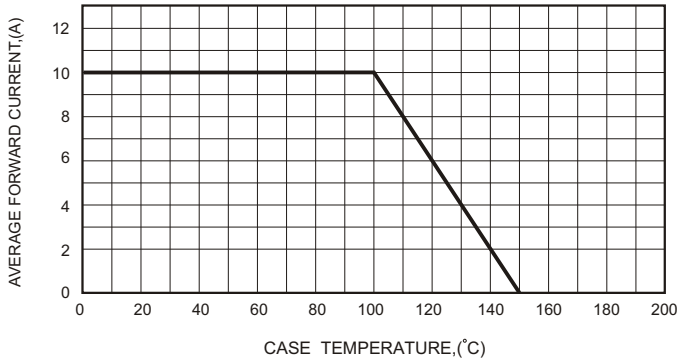

FIG.2-TYPICAL FORWARD CHARACTERISTICS

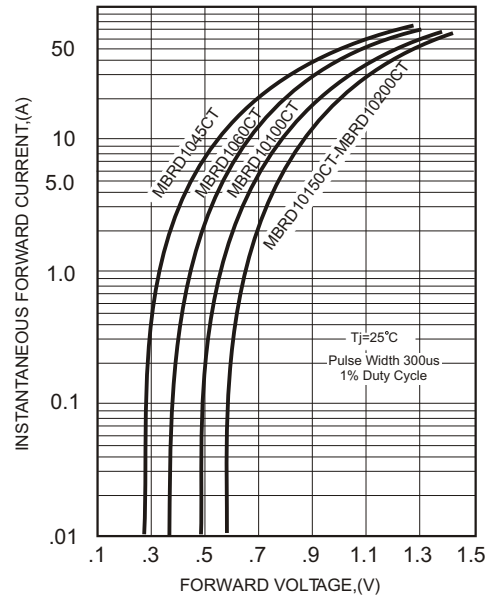

FIG.3-MAXIMUM NON-REPETITIVE FORWARD SURGE CURRENT

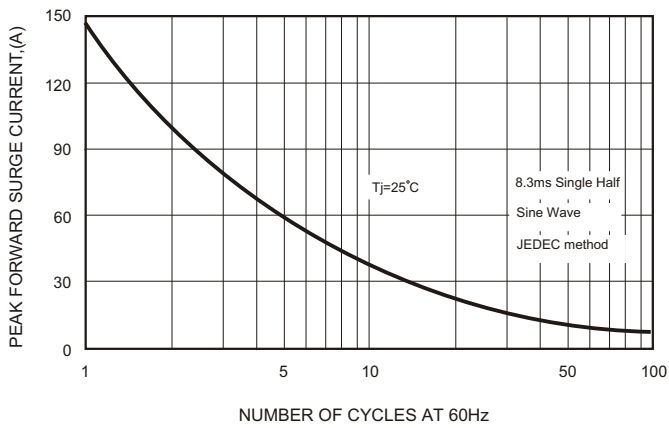

FIG.4-TYPICAL JUNCTION CAPACITANCE

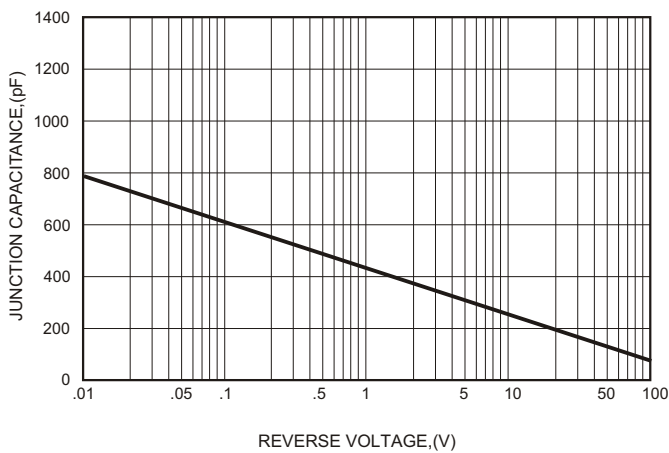

FIG.5 - TYPICAL REVERSE CHARACTERISTICS

