

RoHS

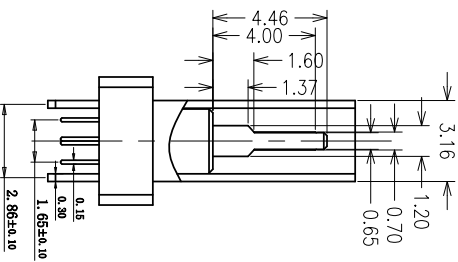

- SPECIFICATIONS:**
- 1. ELECTRICAL CHARACTERISTICS:
 - 1-1. CONTACT RESISTANCE: 3m Ω MIN. Q
 - 1-2. DIELECTRIC WITHSTANDING VOLTAGE: 100V AC FOR ONE MINUTE.
 - 1-3. INSULATING RESISTANCE: 100M Ω MIN. MEASURED BY 500 VDC
 - 2. MECHANICAL CHARACTERISTICS:
 - 2-1. INSERTION FORCE: 0.5-2.0(Ngf/0.8N)
 - 2-2. WITHDRAWAL FORCE: 0.8-2.0(Ngf/0.8N)
 - 3. LIFE TESTS: 10,000 CYCLES.

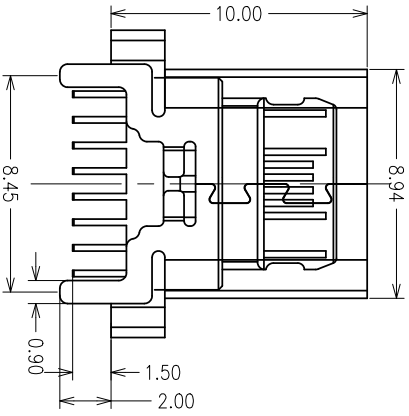
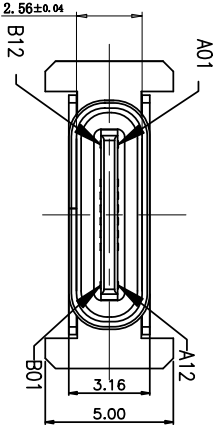
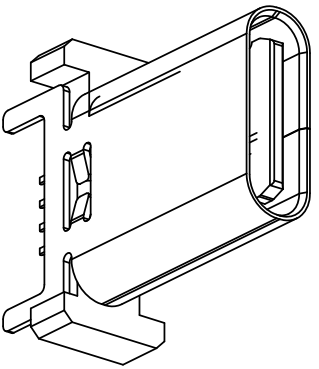
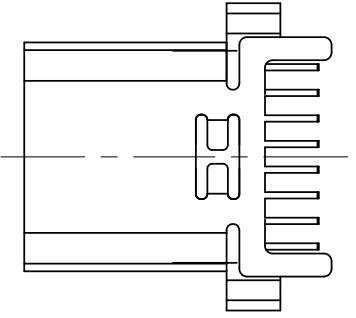
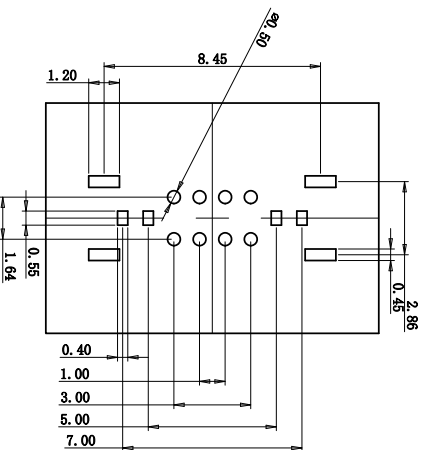

RECOMMENDED P.C.B. LAYOUT (7:1.00mm)
TOLERANCE UNSPECIFIED ±0.05mm

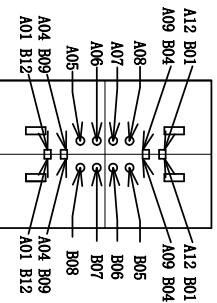

A1	000	000	A12	000	000
A4	000	000	A09	000	000
A5	000	000	A08	000	000
A6	000	000	A07	000	000
A7	000	000	A06	000	000
A8	000	000	A05	000	000
A9	000	000	A04	000	000
A10	000	000	A01	000	000
A11	000	000	B12	000	000
A12	000	000	B01	000	000
A13	000	000	B05	000	000
A14	000	000	B06	000	000
A15	000	000	B07	000	000
A16	000	000	B08	000	000
A17	000	000	B09	000	000
A18	000	000	B10	000	000
A19	000	000	B11	000	000
A20	000	000	B12	000	000

产品图
PRODUCT CHART DWG

公差一览表
TOLERANCE UNLESS OTHERWISE

尺寸	公差	单位
0.15-0.5	±0.35	X
0.5-1.0	±0.25	X
1.0-2.0	±0.20	XX
2.0-5.0	±0.05	XXX
5.0-10.0	±0.1	±1.0°
10.0-15.0	±0.5	±0.5°

深圳市精拓金电子有限公司
Shenzhen Jing Tuo Jin Electronics Co., Ltd.

单位	MM
比例	1:1
日期	2021-03-10
制图	沈一
审核	郭治富
批准	黄国荣
制图料号	918-648R2027Y30011
产品名称	TYPE-C3 1母座10.0立插无弹无
PRODUCT NO.	柱四脚间距8.45(CP)螺柱1.6P1N
角法	角法
版本	版本
版次	AO

MAPX	MODIFICATION	DRW	DATE