

SPECIFICATIONS:

- ELECTRICAL CHARACTERISTICS
 - CURRENT RATING: 0.5 AMP
 - VOLTAGE RATING: 40 V
 - CONTACT RESISTANCE: 30MILLIOHMS MAX
 - INSULATION RESISTANCE: 100M MIN. @500V DC
 - DIELECTRIC WITHSTANDING VOLTAGE: 500V AC FOR 1 MINUTE
- MECHANICAL CHARACTERISTICS:
 - INSERTION FORCE : 4.5KGF MAX.
 - WITHDRAWING FORCE : 1KGF ~ 4KGF.
- LIFE TEST: 10000 CYCLES
- OPERATING TEMPERATURE: -40°C TO +85°C
- PART NO. DESCRIPTION:

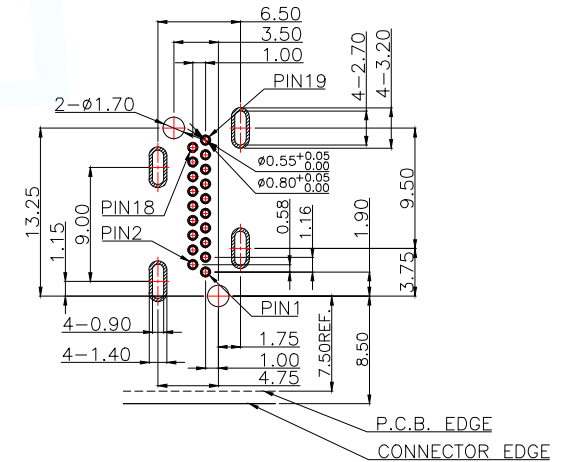
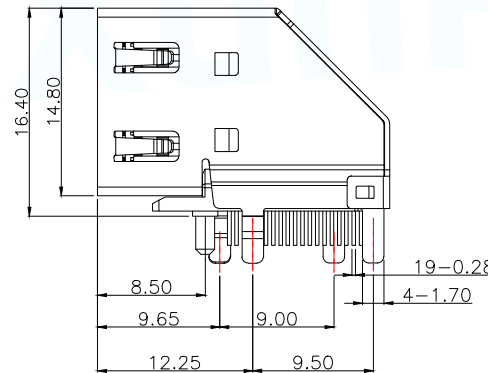
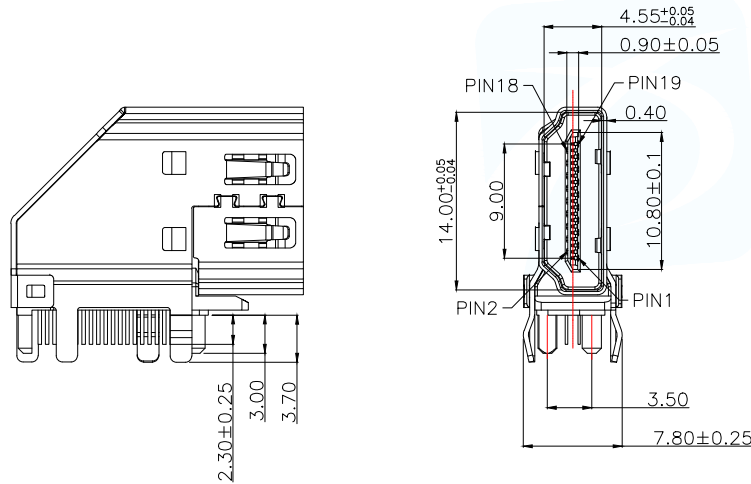

RECOMMENDED PCB LAYOUT

GENERAL TOLERANCE ±0.05

C	SHELL	1	C2680R-H Ni 50u"Min T=0.4mm PLATING ALL OVER
B	TERMINAL	19	C2680R-H,T=0.2±0.05mm
A	HOUSING	1	LCP E130i UL94V-0 BLACK
NO	PART NAME	QTY	MATERIAL PLATING & COLOR

MANUFACTURE DWG		东莞市讯普电子科技有限公司 DongGuan XunPu Electronics Co.,Ltd	
UNLESS OTHERWISE SPECIFIED TOLERANCES			TITLE: HDMI2.1 侧插口镀铜壳镀镍 两K脚两直脚 两K脚间距7.80 针长2.3 端子半全镀镍1u"
DECIMALS:	ANGLES:		PAR: HDMI-001A DWN: Lucas
.X:±0.35	X.':±2'		CHKD: Ethan APVD: Jacob
.XX:±0.25	X.X':±1.5'		SCALE:1:1 UNIT:MM SIZE:A4 SHEET:1F1 REV:A
.XXX:±0.15	X.XX:±1"	CUSTOMER COPY	

每20盒用PE模缠绕包扎紧

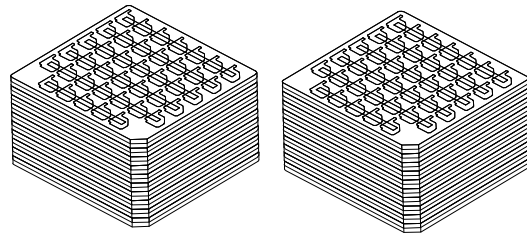

左右各800PCS
共计: 1600PCS

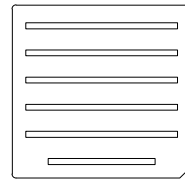

UP COVER

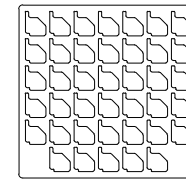

BOTTOM COVER

40PCS/TRAY

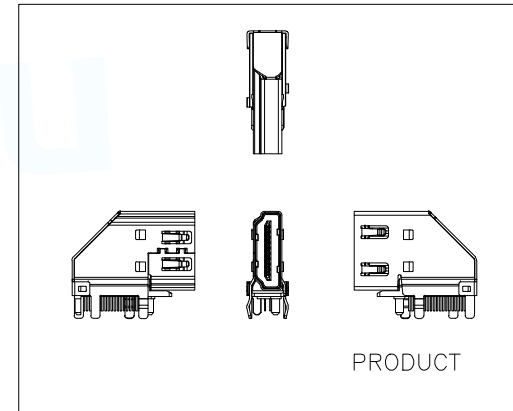
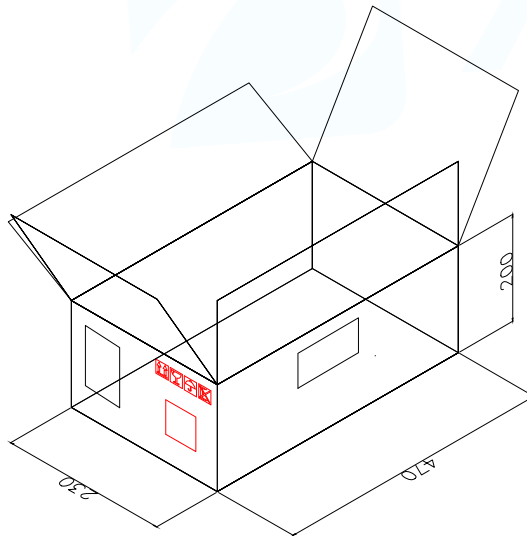
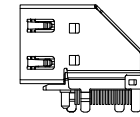

PRODUCT

NOTE:
1.PACKING:40PCS/TRAY,1600PCS/CARTON.
2.CARTON SIZE: 470*230*200mm

MANUFACTURE DWG		 东莞市讯普电子科技有限公司 DongGuan XunPu Electronics Co.,Ltd		
UNLESS OTHERWISE SPECIFIED TOLERANCES			TITLE: HDMI2.1 侧插口镀铜壳玻璃 两K脚两直脚 两K脚间距7.80 针长2.3 端子半全象限1u"	
DECIMALS:	ANGLES:		PAR	HDMI-001A
.X:±0.35	X.°:±2°		DWN	Lucas
.XX:±0.25	X.X°:±1.5°		CHKD	Ethan
.XXX:±0.15	X.XX:±1°		APVD	Jacob
		CUSTOMER COPY	SCALE:1:1 UNIT:MM	
			SIZE:A4 SHEET:1F1	
			REV:A	