

1. FIGURE AND DIMENSIONS (视图及尺寸)

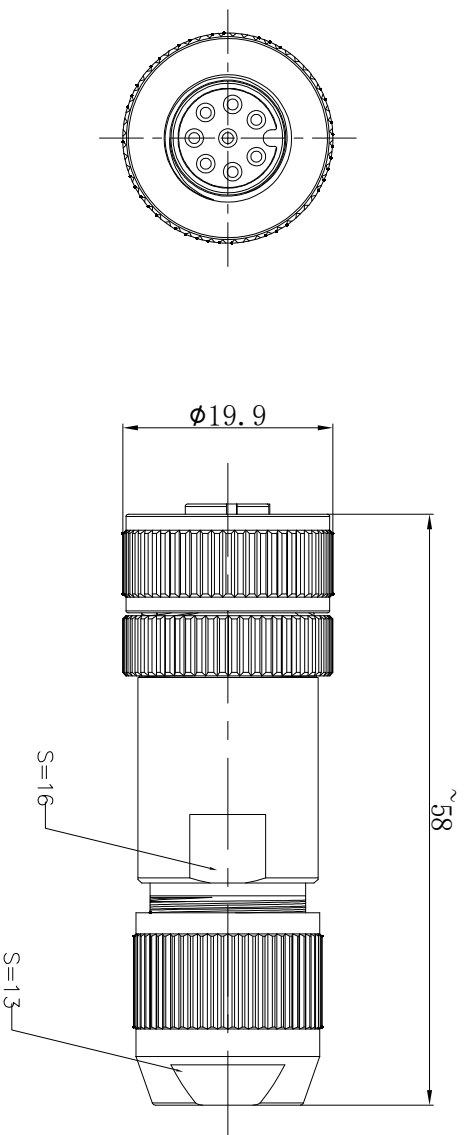

Main technical indicators (主要技术指标)	
1. Mating (插拔次数)	100
2. Working Temperature (温度)	-25~+80°
3. IP Rating (防护级别)	IP 67
4. Diameter of socket end(插合端直径)	See the needle core parameter table/见针芯参数表
5. Rated voltage (额定电压)	
6. Rated Current (额定电流)	Copper alloys are nickel-plated/铜合金镀镍
7. Shell material (壳体材质)	Copper gilding/铜镀金
8. Pin Material (插针材料)	Copper gilding/铜镀金
9. Insulation resistance (绝缘电阻)	> 100MΩ
10. Insulator material (绝缘体材料)	PA66
11. Salt spray test (盐雾测试)	> 72H

针芯性能参数表			
孔位排列	P04	P05	P08
适配线径(AWG)	22AWG	22AWG	24AWG
插合端直径(mm)	1.0	1.0	0.8
额定工作电压 (V)	250V	60V	60V
额定工作电流(A)	4A	4A	2A

Sum up (总结)	
Series (系列)	M12
Shell style/model (外壳样式/型号)	TGA. 9: Fixed receptacle, rear panel mounted/固定式插座, 后面板安装型
Button (按键)	1 button (1个按键)
Termination type (终止类型)	Male solder (公焊锡)
Line diameter awg(线材直径)	See the needle core parameter table/见针芯参数表
Cable diameterφ (电缆直径)	-
Match plug (匹配插头)	TGA. M12. P08. MPA. 9/TGA. M12. P08. NPA. 9/TGA. M12. P08. MPA/TGA. M12. P08. NPA

版本		TITLE		DRAWING NO.		REV.	
REVA4				I. AX. ZSN. M12. P08. NP7		A0	
REVA3				UNIT	mm		
REVA2				SCALE	Free		
REVA1				SHEET	1 OF N		
DRAW		DATE		PART NO.			
CHECK		DATE		USE			
APPR'D		DATE		KKB INDUSTRIAL PRECISION CO., LIMITED			