

## ■ Features

- Two-Wire Serial Interface, I<sup>2</sup>C™ Compatible
  - Bi-directional data transfer protocol
- Wide-voltage Operation
  - $V_{CC} = 1.7V$  to  $5.5V$
- Speed: 400 KHz ( $1.7V$ ) and 1 MHz ( $2.5V\sim 5.5V$ )
- Standby current (max.): 1  $\mu A$ ,  $1.7V$
- Operating current (max.): 2 mA,  $1.7V$
- Hardware Data Protection
  - Write Protect Pin
- Sequential & Random Read Features
- Memory organization: 65,536 x 8 bits
- Page Size: 128 bytes
- Page write mode
  - Up to 128 bytes per page write
- Self timed write cycle with auto clear: 5ms (max.)
- Filtered inputs for noise suppression
- High-reliability
  - Endurance: 1 million cycles
  - Data retention: 100 years
- Industrial temperature grades
- Packages: SOIC/SOP, TSSOP, DFN and CSP
- Lead-free, RoHS, Halogen free, Green

## ■ Description

The AT24C512/CAT24C512 are EEPROM devices that use the

industrial standard 2-wire interface for communications. The 24C512 contains a memory array of 512K-bits (65,536x8), which is organized in 128-byte per page.

The EEPROM can operate in a wide voltage range from 1.7V to 5.5V which fits most application. This product can provide a low-power 2-wire EEPROM solution. The device is offered in Lead-free, RoHS, halogen free or Green. The available package types are 8-pin SOIC/SOP, TSSOP, DFN and CSP.

The 24C512 is compatible with the industrial standard 2-wire bus protocol. If in case the bus is not responded, a new sent Op-code command will reset the bus and the device will respond correctly. The simple bus consists of the Serial Clock wire (SCL) and the Serial Data wire (SDA). Utilizing such bus protocol, a Master device, such as a microcontroller, can usually control one or more Slave devices, alike this 24C512

. The bit stream over the SDA line includes a series of bytes, which identifies a particular Slave device, an instruction, an address within that Slave

device, and a series of data, if appropriate. The 24C512 also has a Write Protect pin (WP) to allow blocking any write operations over specified memory area. Under no circumstance, the device will be hung up. In order to refrain the state machine entering into a wrong state during power-up sequence or a power toggle off-on condition, a power on reset circuit is embedded. During power-up, the device does not respond to any instructions until the supply voltage ( $V_{CC}$ ) has reached an acceptable stable level above the reset threshold voltage. Once  $V_{CC}$  passes the power on reset threshold, the device is reset and enters into the Standby mode. This would also avoid any inadvertent Write operations during power-up stage. During power-down process, the device will enter into standby mode, once  $V_{CC}$  drops below the power on reset threshold voltage. In addition, the device will be in standby mode after receiving the Stop command, provided that no internal write operation is in progress. Nevertheless, it is illegal to send a command unless the  $V_{CC}$  is within its operating level.

Examples

型号	封装	私印	工作电压	兼容电压
AT24C512C-SSHM-T-TUDI	SOP8	24C512C	1.7-5.5	2.7v
CAT24C512WI-GT3-TUDI	SOP8	24512C	1.7-5.5	2.7v
AT24C512C-SSHD-T-TUDI	SOP8	24C512D	1.7-5.5	3.6v
AT24C512B-PU-TUDI	DIP8	24C512B	1.7-5.5	
CAT24C512LI-G-TUDI	DIP8	24C512	1.7-5.5	3.6v
AT24C512C-XHD-T-TUDI	TSSOP8	24512C	1.7-5.5	

■ Functional Block Diagram

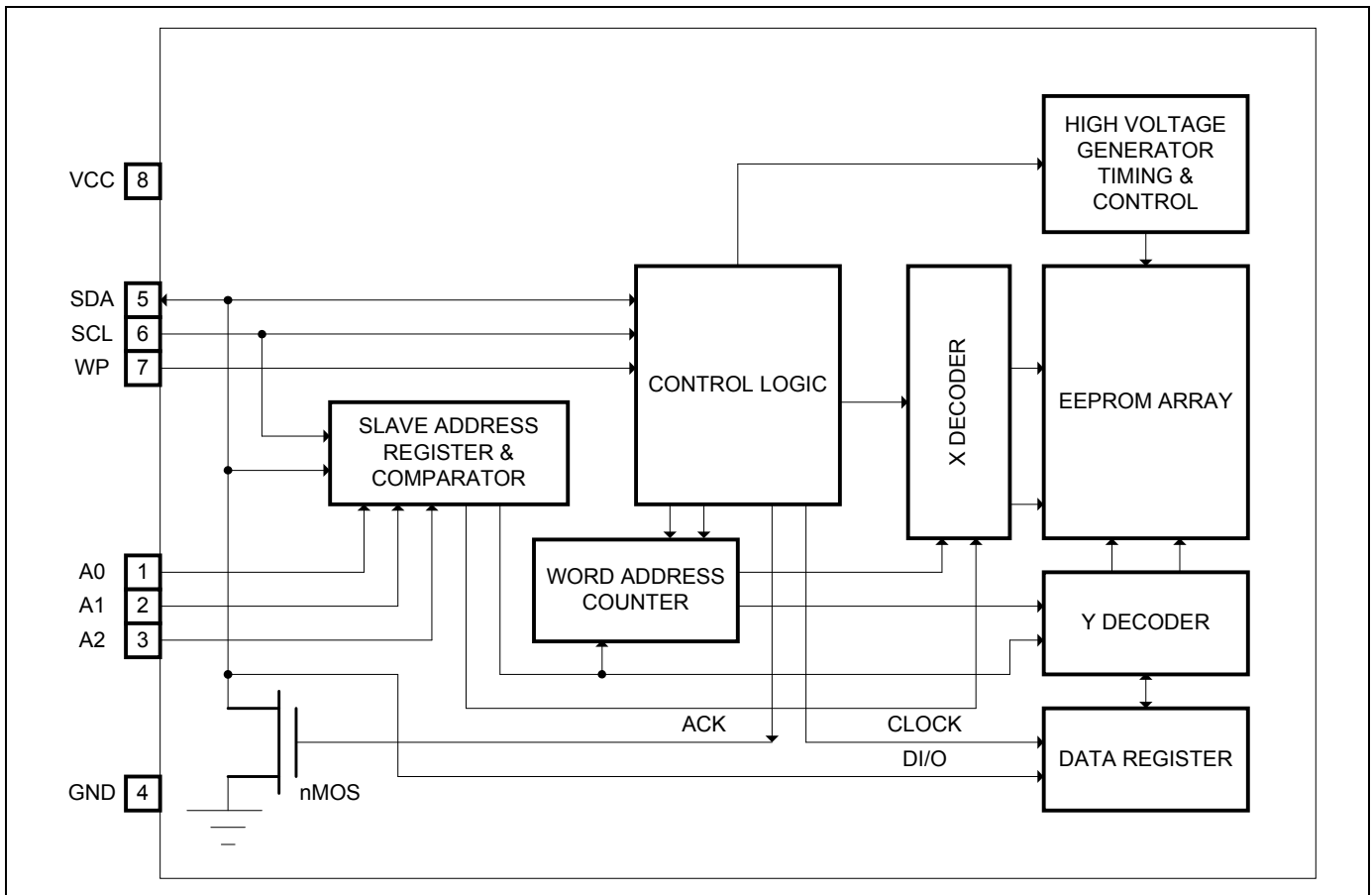

## Pin Configuration

### 8-Pin SOIC/SOP and TSSOP /PDIP

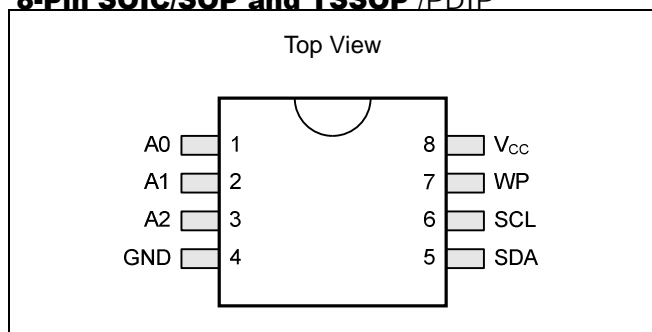

### 8-Lead DFN

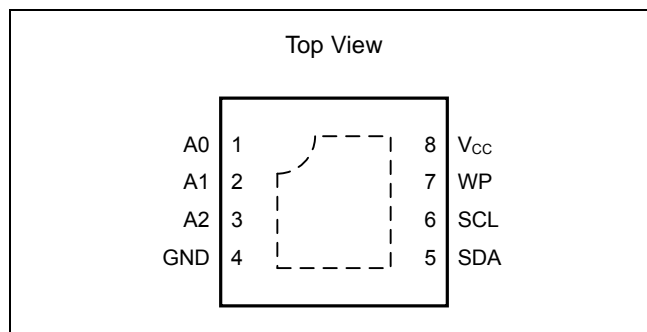

## Pin Definition

Pin No.	Pin Name	I/O	Definition
1	A0	I	Device Address Input
2	A1	I	Device Address Input
3	A2	I	Device Address Input
4	GND	-	Ground
5	SDA	I/O	Serial Address and Data input and Data out put
6	SCL	I	Serial Clock Input
7	WP	I	Write Protect Input
8	V <sub>CC</sub>	-	Power Supply

## Pin Descriptions

### SCL

This input clock pin is used to synchronize the data transfer to and from the device.

### SDA

The SDA is a bi-directional pin used to transfer addresses and data into and out of the device. The SDA pin is an open drain output and can be wired with other open drain or open collector outputs. However, the SDA pin requires a pull-up resistor connected to the power supply.

### A0, A1, A2

The A0, A1 and A2 are the device address inputs.

Typically, the A0, A1, and A2 pins are for hardware addressing and a total of 8 devices can be connected on a single bus system. When A0, A1, and A2 are left floating,

the inputs are defaulted to zero.

### WP

WP is the Write Protect pin. While the WP pin is connected to the power supply of 24C512, the entire array becomes Write Protected (i.e. the device becomes Read only). When WP is tied to Ground or left floating, the normal write operations are allowed.

### V<sub>CC</sub>

Supply voltage

### GND

Ground of supply voltage

## ■ Device Operation

The 24C512 serial interface supports communications using industrial standard 2-wire bus protocol, such as I<sup>2</sup>C.

### 2-WIRE Bus

The two-wire bus is defined as Serial Data (SDA), and Serial Clock (SCL). The protocol defines any device that sends data onto the SDA bus as a transmitter, and the receiving devices as receivers. The bus is controlled by Master device that generates the SCL, controls the bus access, and generates the Start and Stop conditions. The 24C512 is the Slave device.

### The Bus Protocol

Data transfer may be initiated only when the bus is not busy. During a data transfer, the SDA line must remain stable whenever the SCL line is high. Any changes in the SDA line while the SCL line is high will be interpreted as a Start or Stop condition.

The state of the SDA line represents valid data after a Start condition. The SDA line must be stable for the duration of the High period of the clock signal. The data on the SDA line may be changed during the Low period of the clock signal. There is one clock pulse per bit of data. Each data transfer is initiated with a Start condition and terminated by a Stop condition.

### Start Condition

The Start condition precedes all commands to the device and is defined as a High to Low transition of SDA when SCL is High. The EEPROM monitors the SDA and SCL lines and will not respond until the Start condition is met.

### Stop Condition

The Stop condition is defined as a Low to High transition of SDA when SCL is High. All operations must end with a Stop condition.

### Acknowledge

After a successful data transfer, each receiving device is required to generate an ACK. The Acknowledging device pulls down the SDA line.

### Reset

The 24C512 contains a reset function in case the 2-wire bus transmission on is accidentally interrupted (e.g. a power loss), or needs to be terminated mid-stream. The reset is initiated when the Master device creates a Start condition. To do this, it may be necessary for the Master device to

monitor the SDA line while cycling the SCL up to nine times. (For each clock signal transition to High, the Master checks for a High level on SDA.)

### Standby Mode

While in standby mode, the power consumption is minimal. The 24C512 enters into standby mode during one of the following conditions: a) After Power-up, while no Op-code is sent; b) After the completion of an operation and followed by the Stop signal, provided that the previous operation is not Write related; or c) After the completion of any internal write operations.

### Device Addressing

The Master begins a transmission on by sending a Start condition, then sends the address of the particular Slave devices to be communicated. The Slave device address is 8 bits format as shown in Figure. 1-5.

The four most significant bits of the Slave address are fixed (1010) for 24C512 .

The next three bits, A0, A1 and A2, of the Slave address are specifically related to EEPROM. Up to eight 24C512 units can be connected to the 2-wire bus.

The last bit of the Slave address specifies whether a Read or Write operation is to be performed. When this bit is set to 1, Read operation is selected. While it is set to 0, Write operation is selected.

After the Master transmits the Start condition and Slave address byte appropriately, the associated 2-wire Slave device, 24C512 , will respond with ACK on the SDA line.

Then 24C512 will pull down the SDA on the ninth clock cycle, signaling that it received the eight bits of data.

The 24C512 then prepares for a Read or Write operation by monitoring the bus.

### Write Operation Byte Write

In the Byte Write mode, the Master device sends the Start condition and the Slave address information (with the R/W set to Zero) to the Slave device. After the Slave generates an ACK, the Master sends the byte address that is to be written into the address pointer of the 24C512 . After receiving another ACK from the Slave, the Master device transmits the data byte to be written into the address

memory location. The 24C512 acknowledges once more and the Master generates the Stop condition, at which time the device begins its internal programming cycle. While this internal cycle is in progress, the device will not respond to any request from the Master device.

### Page Write

The 24C512 is capable of 128-byte Page-Write operation. A Page-Write is initiated in the same manner as a Byte Write, but instead of terminating the internal Write cycle after the first data word is transferred, the Master device can transmit up to 127 more bytes. After the receipt of each data word, the EEPROM responds immediately with an ACK on SDA line, and the seven lower order data word address bits are internally incremented by one, while the higher order bits of the data word address remain constant.

If a byte address is incremented from the last byte of a page, it returns to the first byte of that page. If the Master device should transmit more than 128 bytes prior to issuing the Stop condition, the address counter will “roll over,” and the previously written data will be overwritten. Once all 128 bytes are received and the Stop condition has been sent by the Master, the internal programming cycle begins. At this point, all received data is written to the 24C512 in a single Write cycle. All inputs are disabled until completion of the internal Write cycle.

### Acknowledge (ACK) Polling

The disabling of the inputs can be used to take advantage of the typical Write cycle time. Once the Stop condition is issued to indicate the end of the host's Write operation, the 24C512 initiates the internal Write cycle. ACK polling can be initiated immediately. This involves issuing the Start condition followed by the Slave address for a Write operation. If the EEPROM is still busy with the Write operation, no ACK will be returned. If the 24C512 has completed the Write operation, an ACK will be returned and the host can then proceed with the next Read or Write operation.

### Read Operation

Read operations are initiated in the same manner as Write operations, except that the (R/W) bit of the Slave address is set to “1”. There are three Read operation options: current address read, random address read and sequential read.

### Current Address Read

The 24C512 contains an internal address counter which maintains the address of the last byte accessed, incremented by one. For example, if the previous operation is either a Read or Write operation addressed to the address location  $n$ , the internal address counter would increment to address location  $n+1$ . When the EEPROM receives the Slave Addressing Byte with a Read operation (R/W bit set to “1”), it will respond an ACK and transmit the 8-bit data byte stored at address location  $n+1$ . The Master should not acknowledge the transfer but should generate a Stop condition so the 24C512 discontinues transmission. If 'n' is the last byte of the memory, the data from location '0' will be transmitted. (Refer to Figure 1-8. Current Address Read Diagram.)

### Random Address Read

Selective Read operations allow the Master device to select at random any memory location for a Read operation. The Master device first performs a 'dummy' Write operation by sending the Start condition, Slave address and byte address of the location it wishes to read. After the 24C512 acknowledges the byte address, the Master device resends the Start condition and the Slave address, this time with the R/W bit set to one. The EEPROM then responds with its ACK and sends the data requested. The Master device does not send an ACK but will generate a Stop condition. (Refer to Figure 1-9. Random Address Read Diagram.)

### Sequential Read

Sequential Reads can be initiated as either a Current Address Read or Random Address Read. After the 24C512 sends the initial byte sequence, the Master device now responds with an ACK indicating it requires additional data from the 24C512. The EEPROM continues to output data for each ACK received. The Master device terminates the sequential Read operation by pulling SDA High (no ACK) indicating the last data word to be read, followed by a Stop condition. The data output is sequential, with the data from address  $n$  followed by the data from address  $n+1, n+2 \dots$  etc. The address counter increments by one automatically, allowing the entire memory contents to be serially read during sequential Read operation. When the memory address boundary of the array is reached, the

address counter “rolls over” to address 0, and the device continues to output data. (Refer to Figure 1-10. Sequential

Read Diagram).

**Diagrams**

**Figure 1-1. Typical System Bus Configuration**

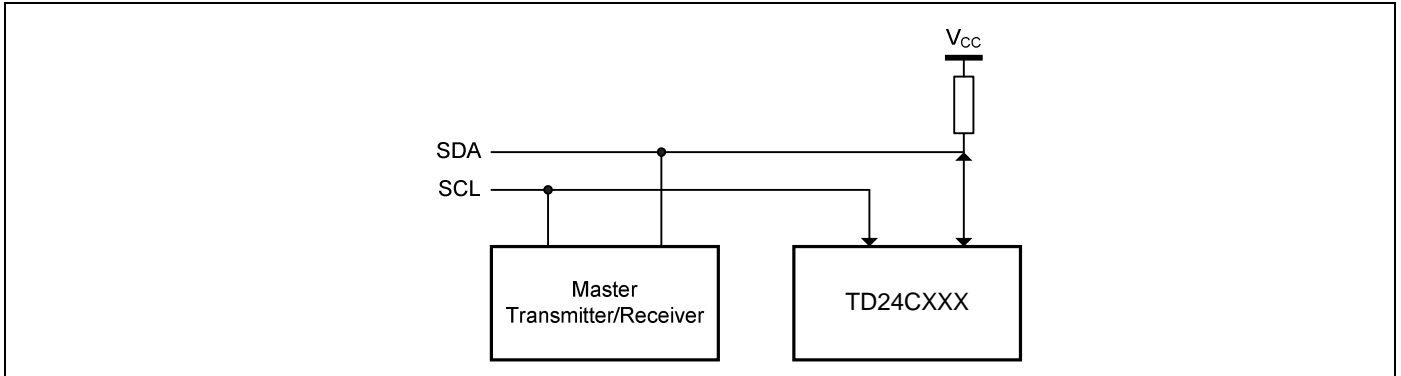

**Figure 1-2. output Acknowledge**

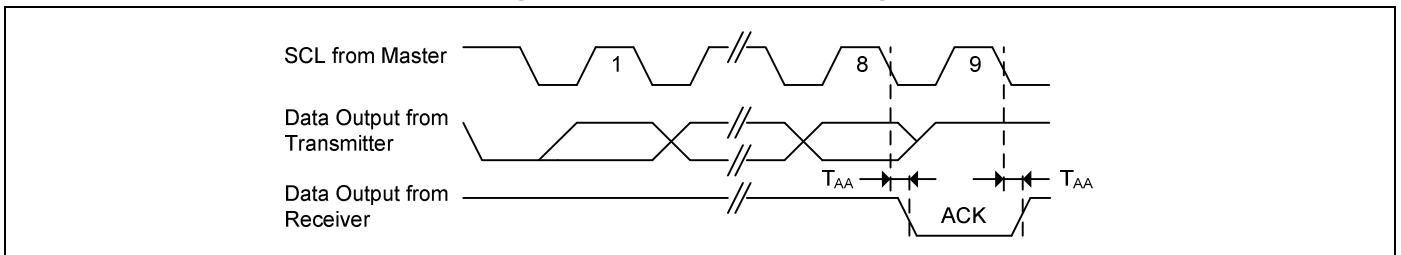

**Figure 1-3. Start and Stop Conditions**

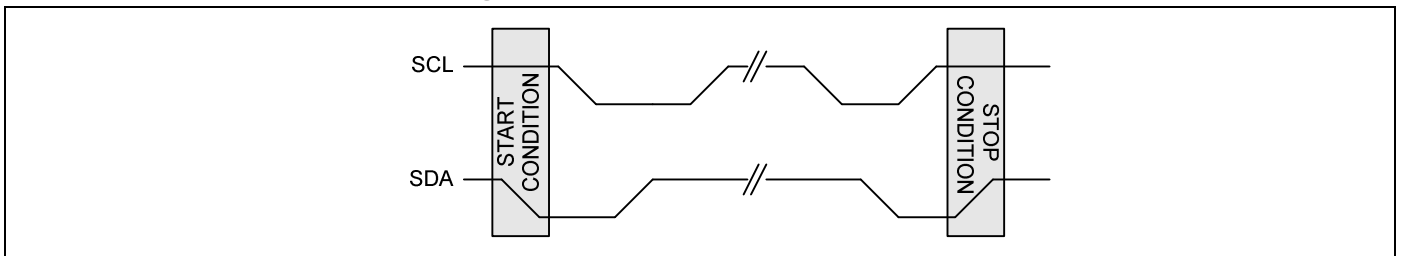

**Figure 1-4. Data Validity Protocol**

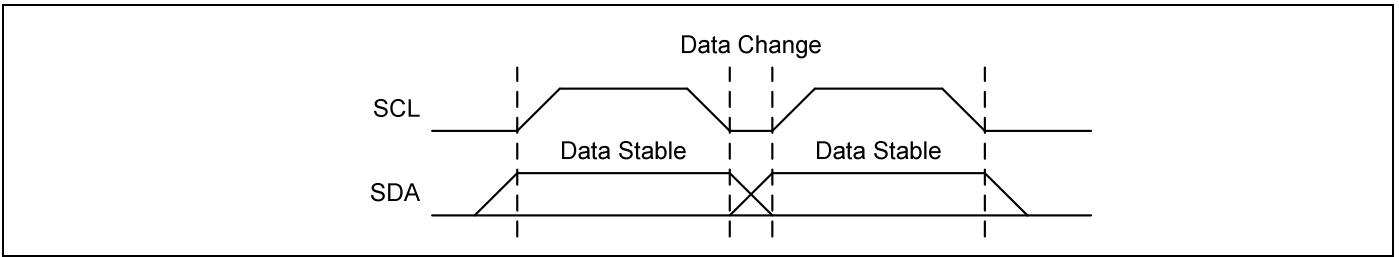

**Figure 1-5. Slave Address**

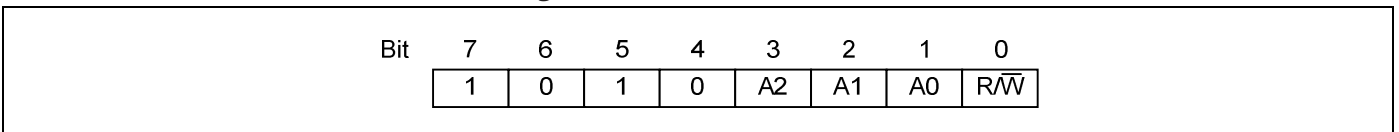

**Figure 1-6. Byte Write**

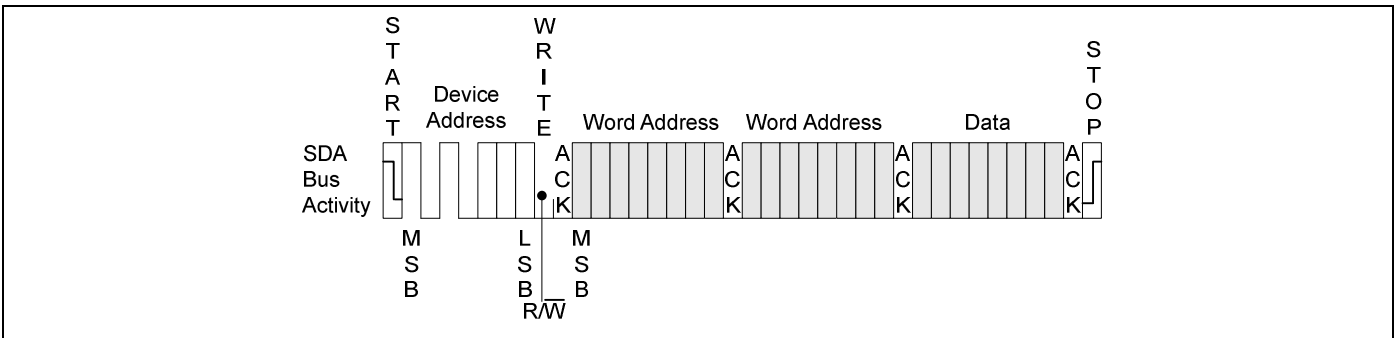

**Figure 1-7. Page Write**

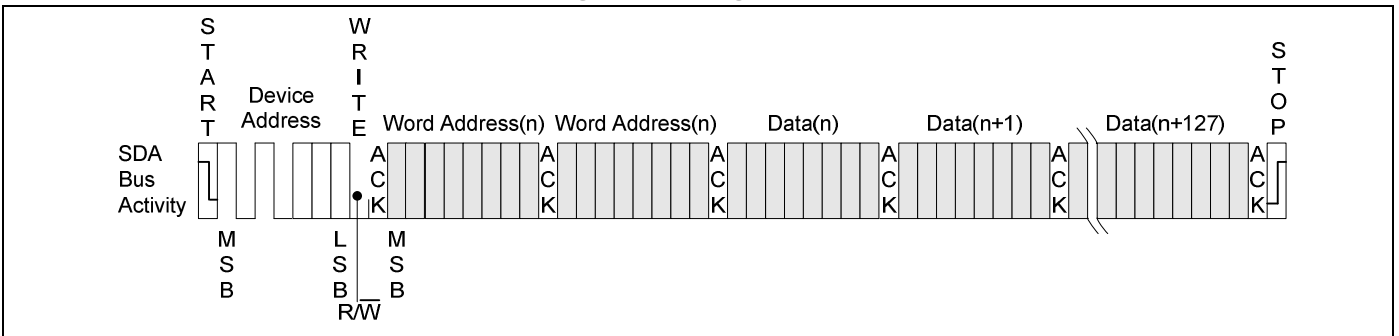

**Figure 1-8. Current Address Read**

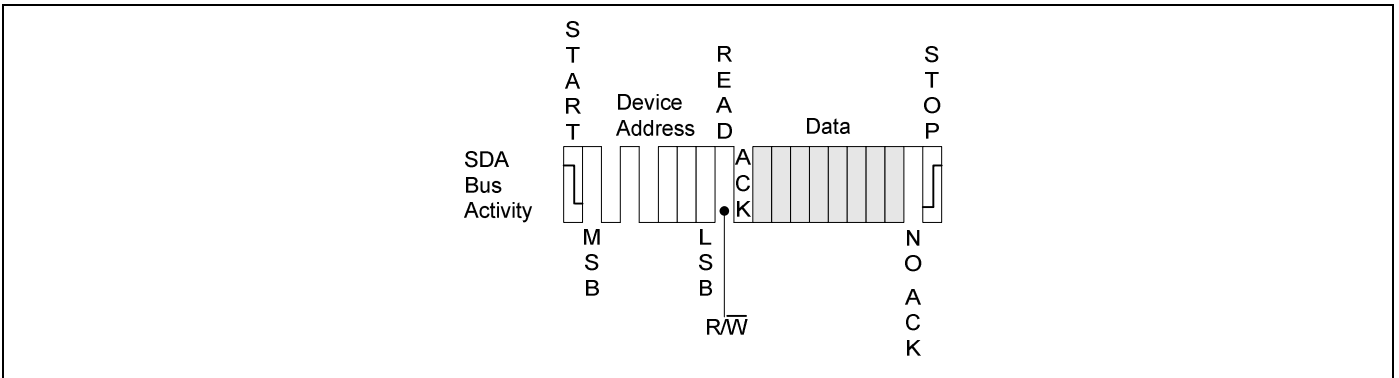

**Figure 1-9. Random Address Read**

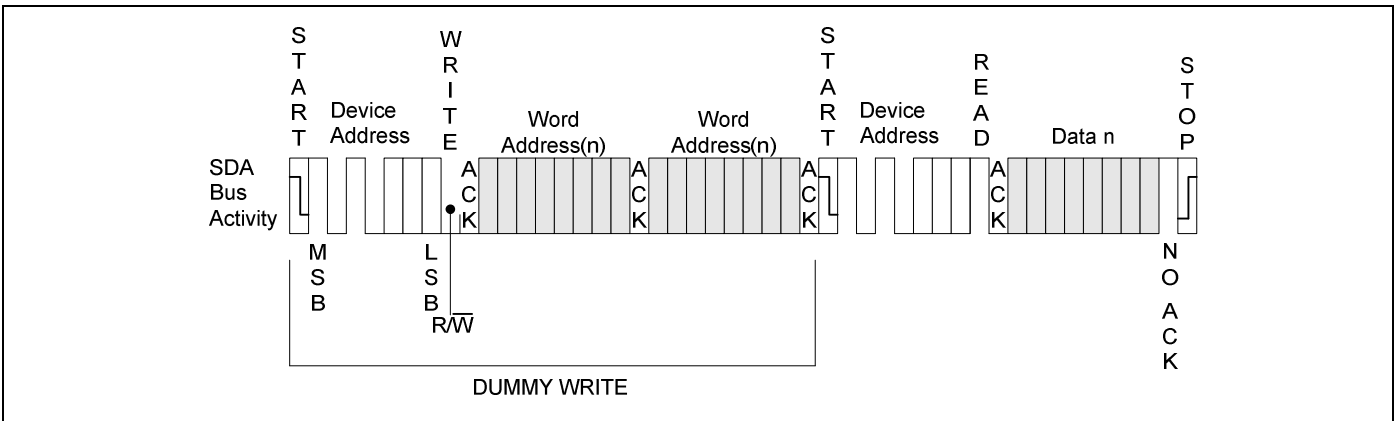

**Figure 1-10. Sequential Read**

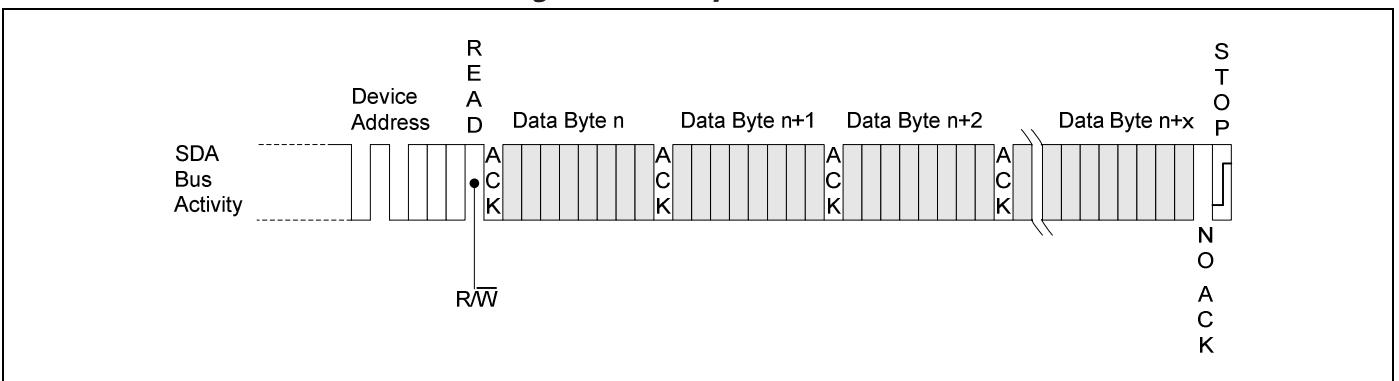



## Timing Diagrams

Figure 1-11. Bus Timing

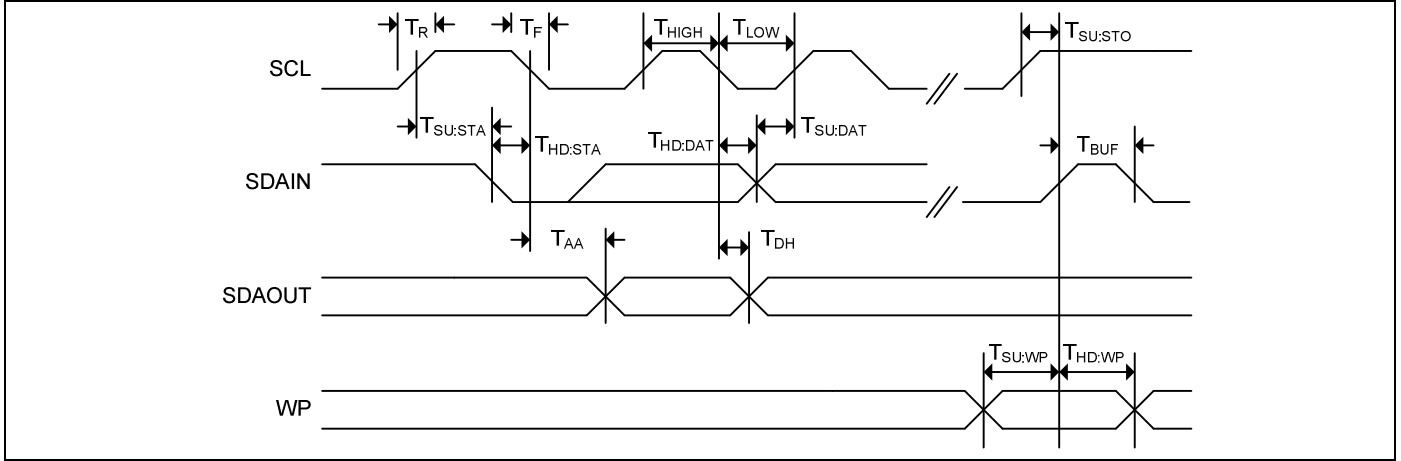
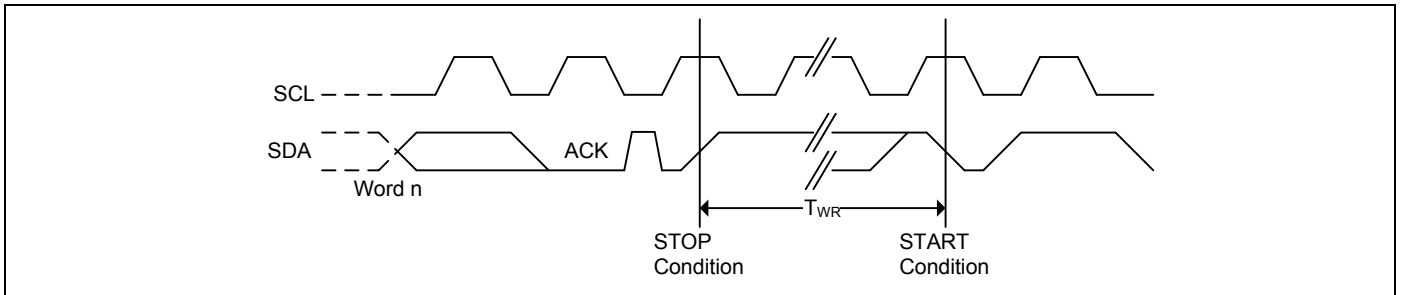

Figure 1-12. Write Cycle Timing



## ■ Electrical Characteristics

### Absolute Maximum Ratings

Symbol	Parameter	Value	Unit
$V_S$	Supply Voltage	-0.5 to + 6.5	V
$V_P$	Voltage on Any Pin	-0.5 to $V_{CC} + 0.5$	V
$T_{BIAS}$	Temperature Under Bias	-55 to +125	°C
$T_{STG}$	Storage Temperature	-65 to +150	°C
$I_{OUT}$	Output Current	5	mA

Note: Stress greater than those listed under Absolute Maximum Ratings may cause permanent damage to the device. This is a stress rating only and functional operation of the device at these or any other condition outside those indicated in the operational sections of this specification is not implied. Exposure to absolute maximum rating conditions for extended periods may affect reliability.

### Operating Range

Range	Ambient Temperature ( $T_A$ )	$V_{CC}$
Industrial	-40°C to +85°C	1.7V to 5.5V

Note: Industrial grade for Commercial applications (0°C to +70°C).

### Capacitance

Symbol	Parameter <sup>[1], [2]</sup>	Conditions	Max.	Unit
$C_{IN}$	Input Capacitance	$V_{IN} = 0V$	6	pF
$C_{I/O}$	Input / Output Capacitance	$V_{I/O} = 0V$	8	pF

Notes: <sup>[1]</sup> Tested initially and after any design or process changes that may affect these parameters and not 100% tested.

<sup>[2]</sup> Test conditions:  $T_A = 25°C$ ,  $f = 1\text{ MHz}$ ,  $V_{CC} = 5.0V$ .

**DC Electrical Characteristic**
**Industrial:  $T_A = -40^{\circ}\text{C}$  to  $+85^{\circ}\text{C}$ ,  $V_{CC} = 1.7\text{V} \sim 5.5\text{V}$** 

Symbol	Parameter <sup>[1]</sup>	$V_{CC}$	Test Conditions	Min.	Max.	Unit
$V_{CC}$	Supply Voltage			1.7	5.5	V
$V_{IH}$	Input High Voltage			$0.7 \cdot V_{CC}$	$V_{CC} + 1$	V
$V_{IL}$	Input Low Voltage			-1	$0.3 \cdot V_{CC}$	V
$I_{LI}$	Input Leakage Current	5 V	$V_{IN} = V_{CC} \text{ max}$	--	2	$\mu\text{A}$
$I_{LO}$	Output Leakage Current	5V		--	2	$\mu\text{A}$
$V_{OL1}$	Output Low Voltage	1.7V	$I_{OL} = 0.15 \text{ mA}$	—	0.2	V
$V_{OL2}$	Output Low Voltage	3V	$I_{OL} = 2.1 \text{ mA}$	—	0.4	V
$I_{SB1}$	Standby Current	1.7V	$V_{IN} = V_{CC} \text{ or GND}$	—	1	$\mu\text{A}$
$I_{SB2}$	Standby Current	2.5V	$V_{IN} = V_{CC} \text{ or GND}$	—	2	$\mu\text{A}$
$I_{SB3}$	Standby Current	5V	$V_{IN} = V_{CC} \text{ or GND}$	—	3	$\mu\text{A}$
$I_{CC1}$	Read Current	1.7V	Read at 400 KHz	—	0.5	mA
		2.5V	Read at 1 MHz		1	mA
		5.5V	Read at 1 MHz		1	mA
$I_{CC2}$	Write Current	1.7V	Write at 400 KHz	—	2	mA
		2.5V	Write at 1 MHz		3	mA
		5.5V	Write at 1 MHz		3	mA

Note: The parameters are characterized but not 100% tested.

注：以上线路及参数仅供参考，实际的应用电路请在充分的实测基础上设定参数。

**AC Electrical Characteristic**
**Industrial:  $T_A = -40^{\circ}\text{C}$  to  $+85^{\circ}\text{C}$ , Supply voltage = 1.7V to 5.5V**

Symbol	Parameter <sup>[1]</sup> <sup>[2]</sup>	1.7V ≤ V <sub>CC</sub> < 2.5V		2.5V ≤ V <sub>CC</sub> < 4.5V		4.5V ≤ V <sub>CC</sub> ≤ 5.5V		Unit
		Min.	Max.	Min.	Max.	Min.	Max.	
F <sub>SCL</sub>	SCK Clock Frequency		400		1000		1000	KHz
T <sub>LOW</sub>	Clock Low Period	1200	—	400	—	400	—	ns
T <sub>HIGH</sub>	Clock High Period	600	—	400	—	400	—	ns
T <sub>R</sub>	Rise Time (SCL and SDA)	—	300	—	300	—	300	ns
T <sub>F</sub>	Fall Time (SCL and SDA)	—	300	—	100	—	100	ns
T <sub>SU:STA</sub>	Start Condition Setup Time	600	—	200	—	200	—	ns
T <sub>SU:STO</sub>	Stop Condition Setup Time	600	—	200	—	200	—	ns
T <sub>HD:STA</sub>	Start Condition Hold Time	600	—	200	—	200	—	ns
T <sub>SU:DAT</sub>	Data In Setup Time	100	—	40	—	40	—	ns
T <sub>HD:DAT</sub>	Data In Hold Time	0	—	0	—	0	—	ns
T <sub>AA</sub>	Clock to Output Access time (SCL Low to SDA Data Out Valid)	100	900	50	400	50	400	ns
T <sub>DH</sub>	Data Out Hold Time (SCL Low to SDA Data Out Change)	100	—	50	—	50	—	ns
T <sub>WR</sub>	Write Cycle Time	—	5	—	5	—	5	ms
T <sub>BUF</sub>	Bus Free Time Before New Transmission	1000	—	400	—	400	—	ns
T <sub>SU:WP</sub>	WP pin Setup Time	600	—	400	—	400		ns
T <sub>HD:WP</sub>	WP pin Hold Time	1200	—	1200	—	1200	—	ns
T	Noise Suppression Time	—	100	—	50	—	50	ns

 Notes: <sup>[1]</sup> The parameters are characterized but not 100% tested.

<sup>[2]</sup> AC measurement conditions:

 R<sub>L</sub> (connects to V<sub>CC</sub>): 1.3 kΩ (2.5V, 5.0V), 10 kΩ (1.7V)

 C<sub>L</sub> = 100 pF

 Input pulse voltages: 0.3\*V<sub>CC</sub> to 0.7\*V<sub>CC</sub>

Input rise and fall times: ≤ 50 ns

 Timing reference voltages: half V<sub>CC</sub> level

**注：以上线路及参数仅供参考，实际的应用电路请在充分的实测基础上设定参数。**

## ■ Package Information

### SOIC/SOP

#### 8L 150mil SOP Package Outline

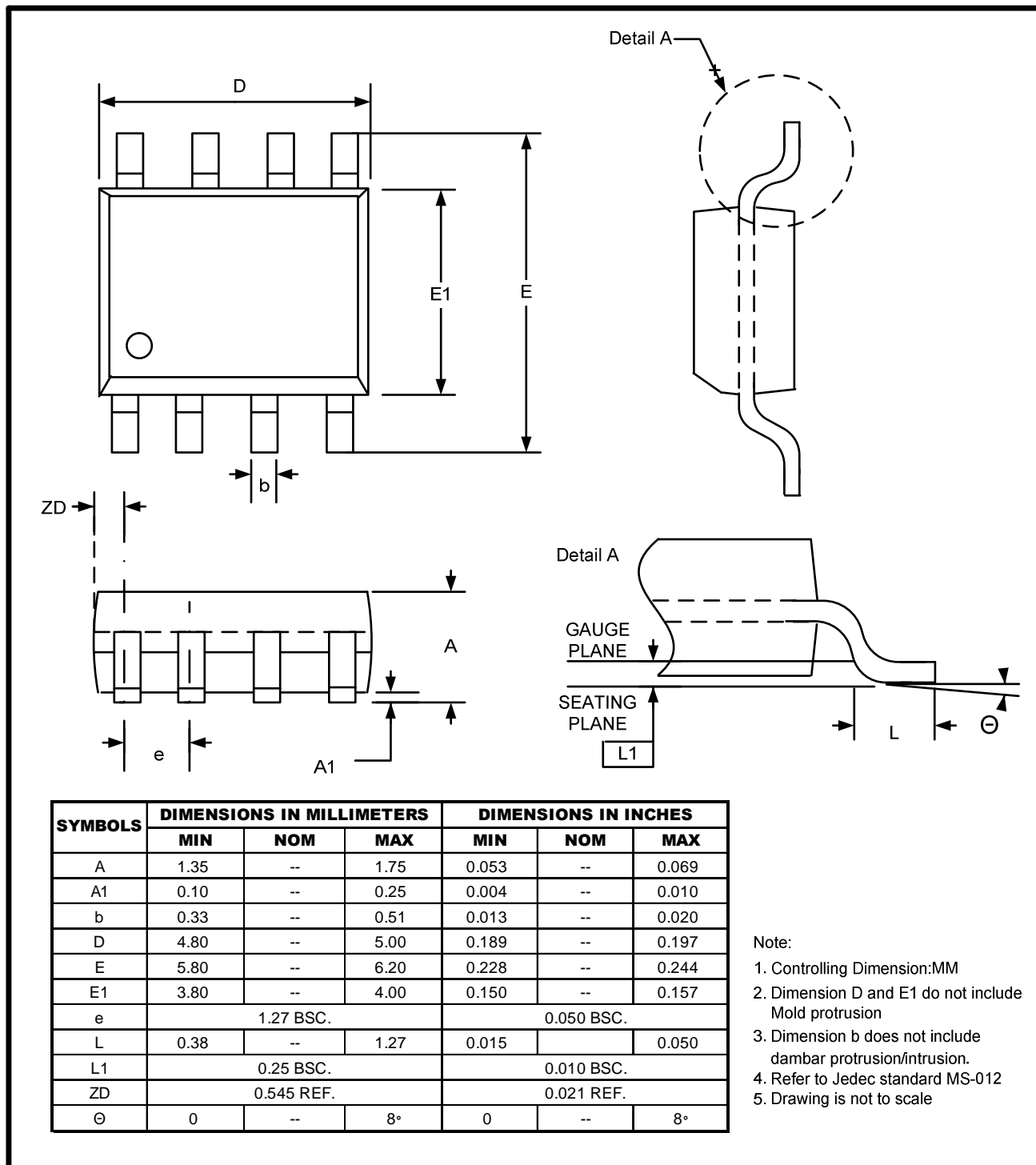

TSSOP

8L 3x4.4mm TSSOP Package Outline

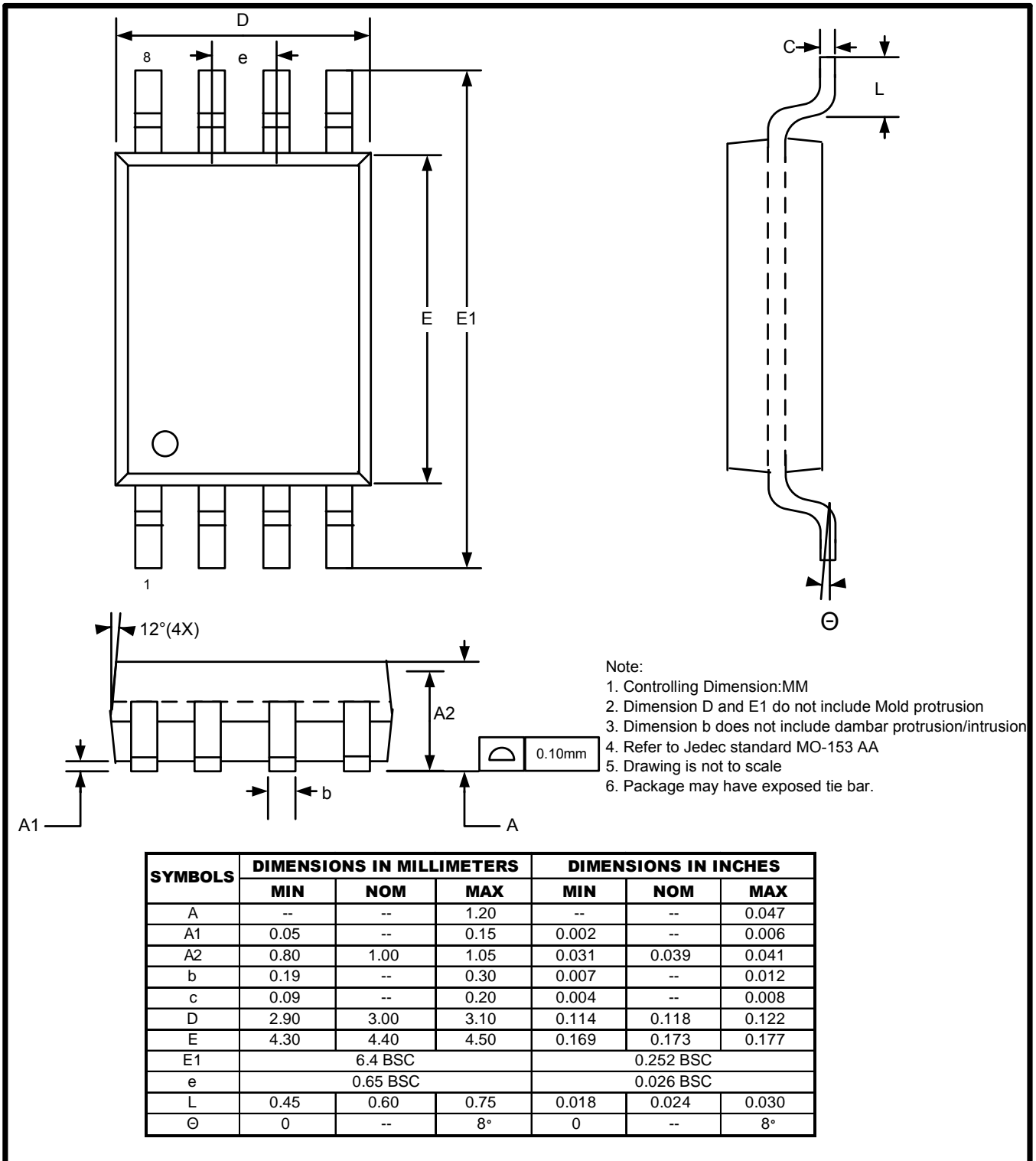

### 重要通知与免责声明

深圳市钜地半导体有限公司将准确可靠地提供技术和可靠性数据（包括数据表）、设计资源（包括参考设计）、应用或其他设计建议、WEB工具、安全信息和其他资源，但不保证任何缺陷，一切以实物测试为准，并且不作任何明示或暗示的保证，包括但不限于对适销性的暗示保证、对特定目的适用的暗示保证或不侵犯任何第三方知识产权的暗示保证。

这些资源旨在为使用钜地产品的熟练开发人员提供支持：（1）为您的应用程序选择合适的产品；（2）设计、验证和测试您的应用程序；（3）确保您的应用程序符合适用的标准和任何其他安全、安保或其他要求；（4）钜地和钜地标志是钜地半导体的注册商标。所有商标均为其各自所有者的财产；（5）有关更改详情，请查阅任何修订文件中包含的修订历史记录。资源可能会在不通知的情况下更改。我公司将不对使用此产品及其使用而导致的专利或第三方知识产权的侵权负责。