

RoHS

Specification

规格书

Customer Name:

客户名称: _____

Customer P/N:

客户品号: _____

Factory P/N:

公司品号: _____

GT-3528U39FC-T30-2

Sending Date:

送样日期: _____

Client approval 客户审核			Goozo approval 鸿利国泽审核		
Approval 核准	Audit 确认	Confirmation 制作	Approval 核准	Audit 确认	Confirmation 制作
			潘桂建	赵丹	程
<input type="checkbox"/> Qualified 接受		<input type="checkbox"/> Disqualified 不接受		DATE: 日期:	



Address: Dangui Road NO. 1 Dantu Area Zhenjiang City Jiangsu Province

地址: 江苏省镇江市丹徒高新开发区丹桂路1号

Tel/电话: 0511-88782599

Fax/传真: 0511-88786599

Web/网址: www.goozo.com.cn

注:

1. 此规格书以中英文方式书写, 若有冲突以中文版本为准文本.
2. 此规格书的最终解释权归属江苏鸿利国泽光电科技有限公司

Features(特征)

- PLCC-2 Package.(PLCC-2 封装)
- Extremely wide viewing angle. (宽的发光角度)
- Suitable for all SMT assembly and solder process. (适用于所有的 SMT 组装和焊接工艺)
- Available on tape and reel. (适用于载带及卷轴)
- Moisture sensitivity level: Level 4. (防潮等级 Level 4)
- Package:2000pcs/reel.(包装每卷 2000PCS)
- RoHS compliant. (RoHS 认证)



Description (描述)

The Red source color devices are made with AlGaInP on Substrate Light Emitting Diode

红光 LED 由 AlGaInP 四种元素芯片激发而成

After the product life cycle for recycling
 产品生命周期后进行回收处理



ATTENTION

OBSERVE PRECAUTIONS
 FOR HANDLING
 ELECTROSTATIC
 DISCHARGE
 SENSITIVE
 DEVICES

注意：操作时应注意静电敏感
 释放设备装置

Applications (应用)

- Optical indicator (光学指示)
- General use (一般应用)

Package Dimensions (封装尺寸)

Recommended Soldering Pattern (建议焊盘尺寸图)

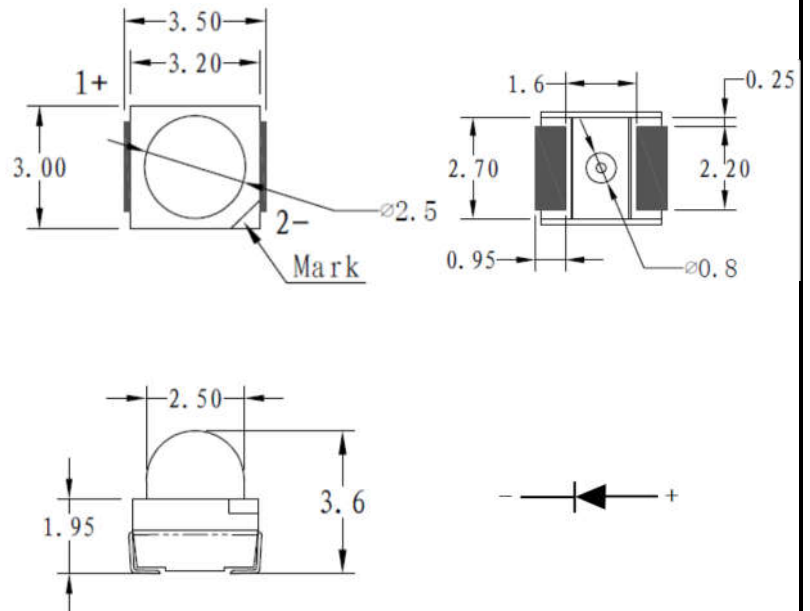
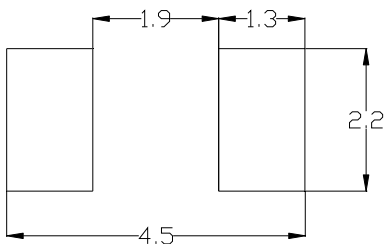

Notes: (备注)

1. All dimension units are millimeters. (所有标注尺寸单位为毫米)
2. All dimension tolerance is $\pm 0.15\text{mm}$ unless otherwise noted. (除特别标注外, 所有尺寸允许公差 $\pm 0.15\text{mm}$)

Selection Guide (选择指南)

Tolerance Grade/公差等级	Dimension Tolerance/尺寸 (Unit:mm)			
	0.5~3	3~6	6~30	30~120
	±0.1	±0.2	±0.3	±0.5
Chip/晶片			Lens Color/胶体颜色	
Material/材质	Emitting Color/ 发光颜色		White Diffused/白色散射	
AlGaInP	Red/红色			

Absolute Maximum Rating

Item 项目	Symbol 符号	Value 数值	Unit 单位
Forward Current 正向电流	IF	20	mA
Peak Forward Current* 峰值正向电流	IFP	80	mA
Reverse Voltage 反向电压	VR	5	V
Power Dissipation 功耗	PD	48	mW
Electrostatic discharge 抗静电能力	ESD	2000	V
Operation Temperature 操作温度	Topr	-30~+85	°C
Storage Temperature 储存温度	Tstg	-40~+100	°C
Lead Soldering Temperature* 引脚焊接温度	Tsol	Max. 260°C for 5sec Max.	

Typical Optical/ Electrical Characteristics Ta=25°C

Item/项目	Symbol/符号	Condition/条件	Rank/档次	Min. 最小值	Typ. 典型值	Max. 最大值	Unit 单位
Luminous Intensity /光强	Iv	IF=20mA		3000	--	5860	mcd
Forward Voltage/正向电压	VF			1.8	--	2.4	V
Dominant Wavelength/主波长	λ_d			618	--	627	nm
Viewing Angle/角度	2 θ 1/2			--	30	--	deg
Recommend Forward Current/ 推荐使用正向电流	IF(rec)	--		--	--	20	mA
Reverse Current/反向电流	IR	V _R =5V		--	--	10	uA

Notes: (备注)

Tolerance : VF \pm 0.1V, λ_d \pm 2 nm, IV(ϕ V) \pm 15%, 2 θ 1/2 \pm 15%, X/Y \pm 0.005.

公差: 正向电压 \pm 0.1V, 主波长 \pm 2 nm, 光强 (光通量) \pm 15%, 角度 \pm 15%, X/Y \pm 0.005.

Typical optical characteristics curves 典型光学特性曲线

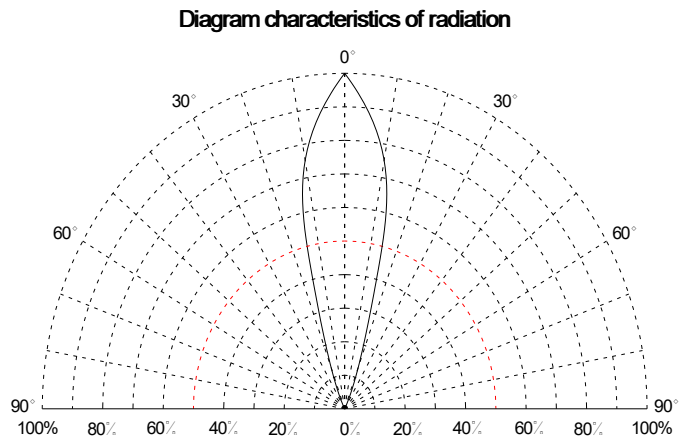
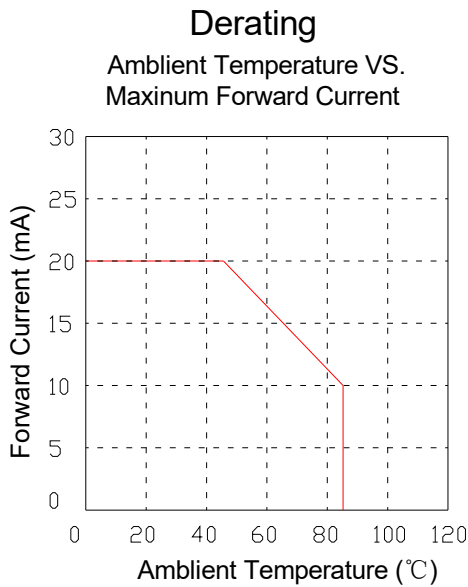
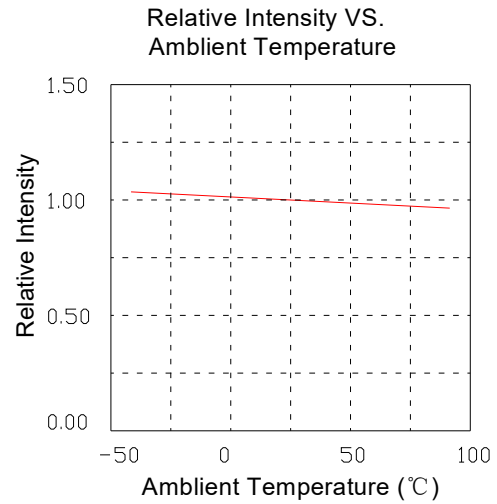
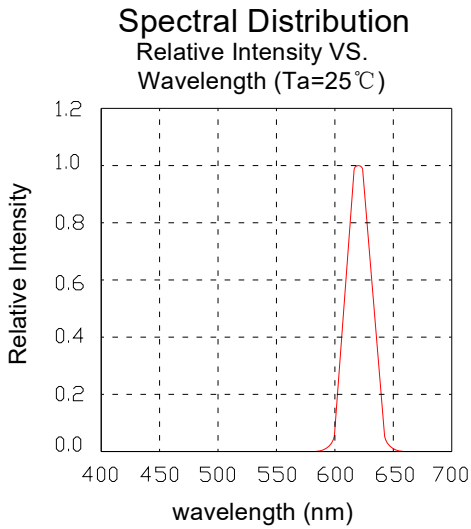
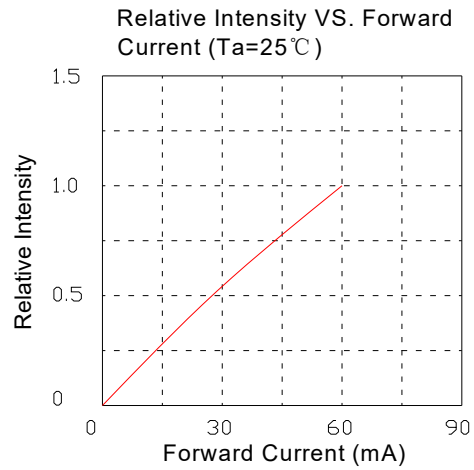
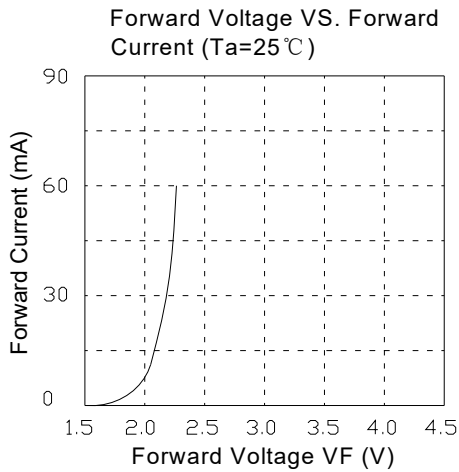

Reliability Test Items And Conditions 信赖性测试项目及条件

Test Classification 测试类别	Test Item 测试项目	Test Conditions 测试条件	Test Duration 测试持续时间	Sample Size 样品数量	AC/RE 接受/拒收
Life Test 寿命测试	Room Temperature DC Operating Life Test 室温直流寿命测试	Ta=25°C±5°C, If=20mA	1000 hrs	22 pcs	0/1
Environment Test 环境模拟实验	Thermal Shock Test 冷热冲击	100°C±5°C 5min ↑↓ -40°C±5°C 5min.	100 cycles	22 pcs	0/1
	Temperature Cycle Test 高低温循环实验	100°C±5°C 30min ↑↓5min -40°C±5°C 30min.	100 cycles	22 pcs	0/1
	High Temperature & High Humidity Test 高温高湿实验	60°C ± 5°C / 90% RH If=20mA	1000 hrs	22 pcs	0/1
	High Temperature Storage 高温储存	Ta=100°C ± 5°C	1000 hrs	22 pcs	0/1
	Low Temperature Storage 低温储存	Ta=-40°C ± 5°C	1000 hrs	22 pcs	0/1
Mechanica Test 机械测试	Resistance to Soldering Heat 耐焊接实验	Temp=260°Cmax T=5sec max	1times	22 pcs	0/1

Failure criteria

Item	Symbol	Test Conditions	Criterial for judgment	
			Min	Max
Forward Voltage	VF	If=20mA	-	U. S. L*1.2
Reverse Current	IR	VR=5V	-	U. S. L*2.0
Luminous Flux	Φ	If=20mA	L. S. L*0.7	-

If the led is not dead and meets the above requirements, it is deemed qualified.

PS: U.S.L:Upper Standard Level L.S.L:Lower Standard Level

SMT Reflow Soldering Instructions SMT 回流焊说明

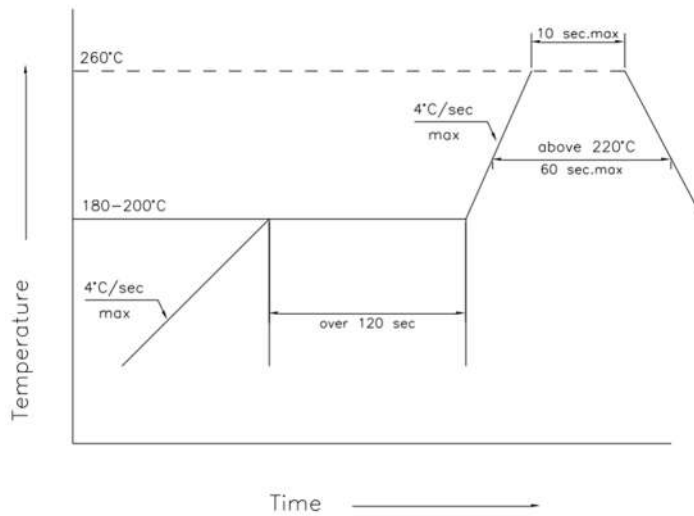

1.Reflow soldering should not be done more than three times. 回流焊不可以做三次以上

2.When soldering , do not put stress on the LEDs during heating

当焊接时，不要在材料受热时用力压胶体表面

Soldering iron 烙铁焊接

1.When hand soldering, keep the temperature of iron below less 350°C less than 5 seconds

当手工焊接时，烙铁的温度必须小于 350°C，时间不可超过 5 秒

2.The hand solder should be done only one times

手工焊接只可焊接一次

Repairing 修补

Repair should not be done after the LEDs have been soldered. When repairing is unavoidable, a double-head soldering iron should be used (as below figure). It should be confirmed in advance whether the characteristics of LEDs will or will not be damaged by repairing.

LED 回流焊后不应该修复，当修复是不可避免时，必须使用双头烙铁（如下图），但必须先确认此种方式会或不会损坏 LED 本身的特性。

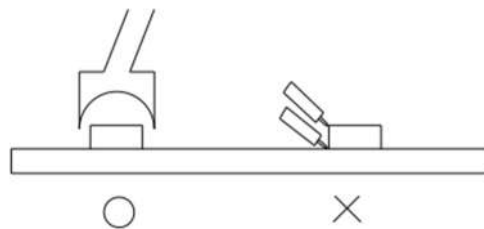

Cautions 注意事项

The encapsulated material of the LEDs is silicone. Therefore the LEDs have a soft surface on the top of package. The pressure to the top surface will be influence to the reliability of the LEDs. Precautions should be taken to avoid the strong pressure on the encapsulated part. So when use the picking up nozzle, the pressure on the silicone resin should be proper.

LED 封装为硅胶，故 LED 胶体表面较软，用力按压胶体表面会影响 LED 可靠性，因此应有预防措施避免在封装的零件上的强大压力，当使用吸嘴时，胶体表面的压力应是恰当的。

Handling Precautions 处理防备措施

Compare to epoxy encapsulant that is hard and brittle, silicone is softer and flexible. Although its characteristic significantly reduces thermal stress, it is more prone to damage by external mechanical force. As a result, Special handling precautions must be observed during assembling using silicone encapsulated LED products, Failure to comply might leads to damage and premature failure of the LED.

相对环氧树脂较脆较硬而言，硅胶封装较柔软且有弹性，虽然它的特性大大减少了热应力，但易受机械外力损坏，因此在手工处理方面须要对硅胶封装材料做预防措施，若未按要求操作，可能会导致 LED 损坏和光衰

1.Handle the component along the side surface by using forceps or appropriate tools; do not directly touch or Handle the silicone lens surface, it may damage the internal circuitry.

通过使用适当的工具从材料侧面夹取，不可直接用手或尖锐金属压胶体表面，它可能会损坏内部电路

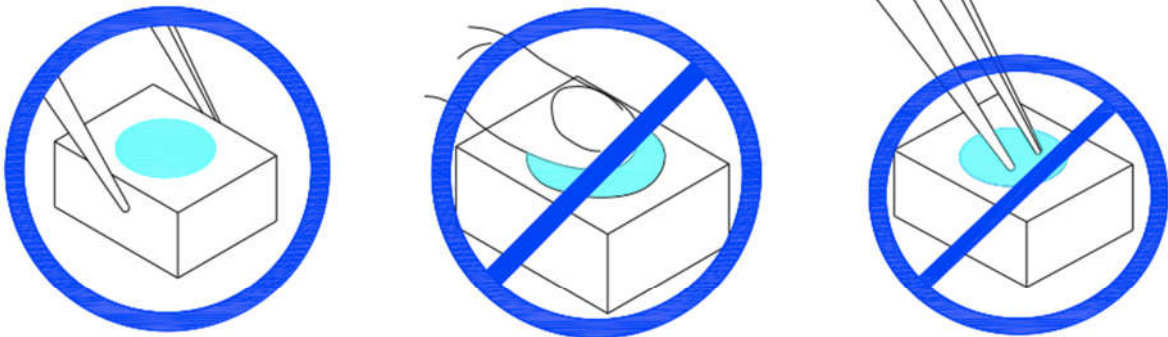

2.The outer diameter of the SMD pickup nozzle should not exceed the size of the LED to prevent air leaks. The inner diameter of the nozzle should be as large as possible. A pliable material is suggested for the nozzle tip to avoid scratching or damaging the LED surface during pickup. The dimensions of the component must be accurately programmed in the pick-and-place machine to insure precise pickup and avoid damage during production.

为防止气压泄漏，SMD 吸咀外径不可以超过 LED 尺寸，吸咀内径尺寸应尽可能大，吸咀顶端材质建议采用柔软材料以防在吸取期间刮伤或损坏 LED 胶体表面，元件的尺寸必须在取放机里准确的编程好，以确保精确的吸取和避免生产过程中的损害



3.Do not stack together assembled PCBs containing LEDs. Impact may scratch the silicone lens or damage the internal circuitry

不可将模组材料堆积在一起，它可能会损坏内部电路

4.Not suitable to operate in acidic environment, PH<7

不可用在PH<7的酸性场所

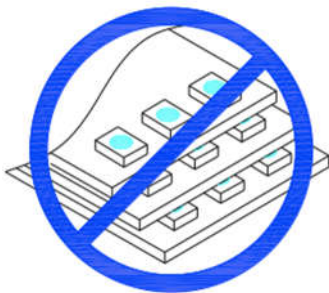

5.LED operating environment and sulfur element composition cannot be over 100PPM in the LED mating usage material.

LED 工作环境及与 LED 适配的材料中硫元素及化合物成份不可超过 100PPM

6.When we need to use external glue for LED application products, please make sure that the external glue matches the LED packaging glue. Additionally ,as most of LED packaging glue is silica gel, and it has strong Oxygen permeability as well as strong moisture permeability; in order to prevent external material from getting into the inside of LED, which may cause the malfunction of LED, the single content of Bromine element is required to be less than 900PPM,the single content of Chlorine element is required to be less than 900PPM,the total content of Bromine element and Chlorine element in the external glue of the application products is required to be less than 1500PPM

当我们需要使用外封胶涂抹 LED 产品时, 应确保外封胶与 LED 封装胶水相匹配, 因为大多数 LED 的封装胶水为硅胶, 它有较强的氧化性和较强的吸湿性, 必须防止外封材质进入 LED 内部以造成 LED 的损伤, 单一的溴元素含量要求小于 900PPM, 单一氯元素含量要求小于 900PPM, 在涂抹 LED 产品时要求外封胶溴元素与氯元素总含量必须小于 1500PPM

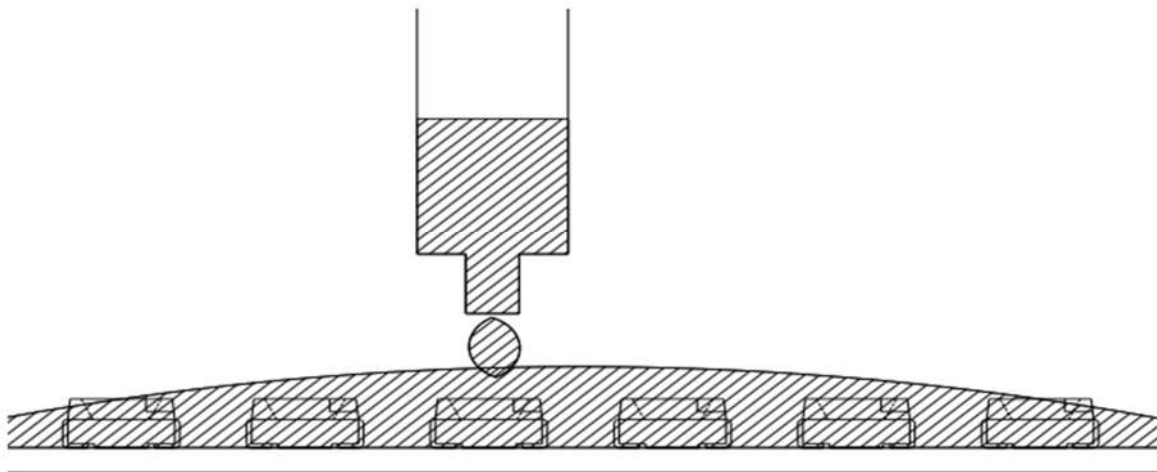

7.Other points for attention, please refer to our LED user manual , In accordance with the user manual, the product shelf life is 24 months , If there is a warranty agreement, the warranty agreement shall prevail

其它注意事项请参照我们的 LED 使用手册, 符合使用手册的情况下, 产品保质期为 24 个月, 已签订保质协议的则以保质协议为准

Label 标签

IV: Luminous intensity rank 亮度等级

WD: Dominate Wavelength 波长等级

VF: Forward voltage rank 电压等级



HONGLI GOOZO
 鸿利国泽光电

RoHS

TYPENO: _____

IV (LM) : _____

WD (nm) : _____

VF (V) : _____

IF (mA) : _____

Tape Specifications (Units : mm) 载带规格 (单位: mm)

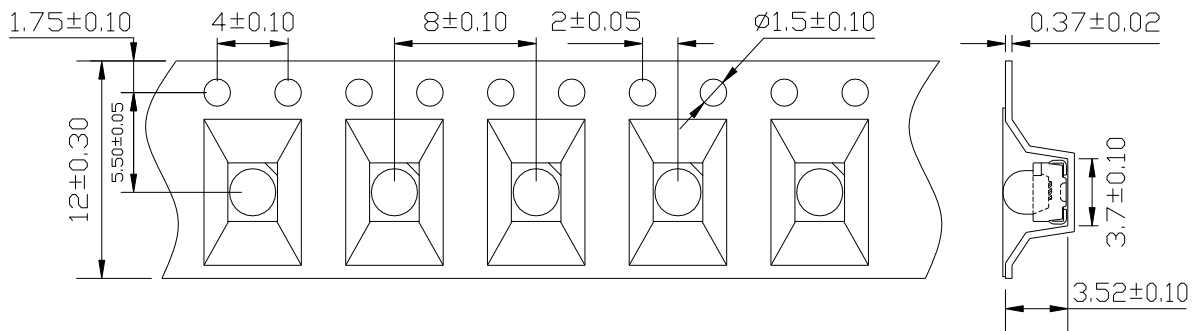

Reel Dimensions

卷轴尺寸

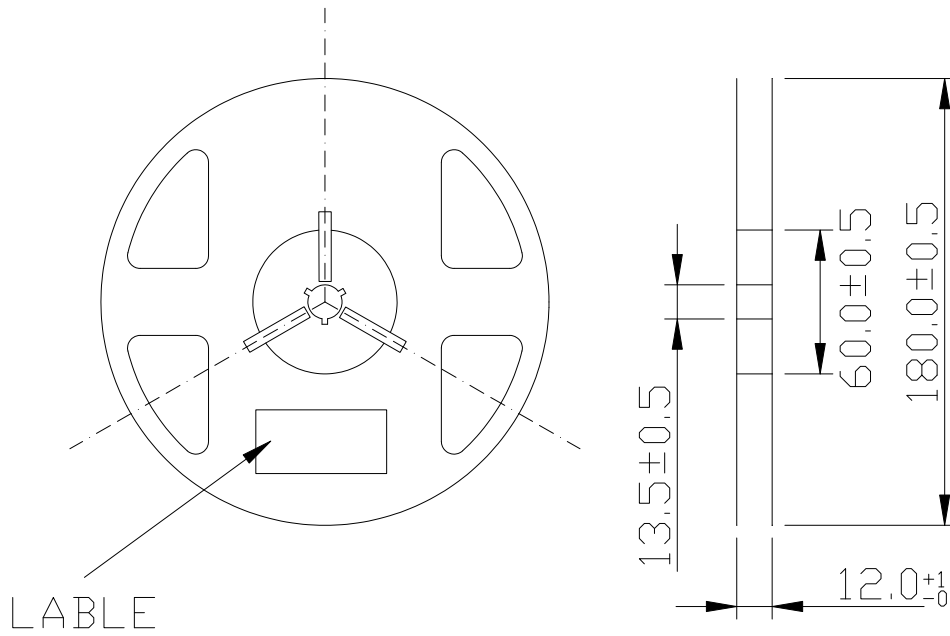

Moisture Resistant Packaging 防潮带包装



Note: The tolerances unless mentioned is ± 0.1 mm, Unit: mm 注: 标注公差为 ± 0.1 mm, 单位: mm