

Supply Voltage Supervisor with Manual Reset Input

1 FEATURES

- Operating Voltage Range:1.0V to 5.5V
- Low Power Consumption:10 μ A (Max)
- Precision Supply-Voltage Monitor: 2.63V, 2.93V, 3.08V, 4.00V
- Debounced TTL/CMOS Compatible Manual-Reset Input
- Guaranteed $\overline{\text{RESET}}$ Valid at $V_{CC}=1.0V$
- 160ms Reset Pulse Width
- Voltage Monitor for Power-Fail or Low-Battery Warning
- Operating Temperature Range: -40°C to +125°C
- Available in Green Package: SOT-143

2 APPLICATIONS

- Computers
- SOC 、 DSP or Micro controllers
- Embedded Systems
- Industrial Equipment
- Intelligent Instruments
- Critical μ P Power Monitoring
- Wireless Communications Systems

3 DESCRIPTIONS

The RS811 microprocessor (μ P) supervisory circuits reduce the complexity and number of components required to monitor power-supply and battery function in μ P systems. This device significantly improves system reliability and accuracy compared to separate ICs or discrete components.

The RS811 provide three functions:

- 1) A reset output during power-up, power-down, and brownout conditions. The reset output remains operational with V_{CC} as low as 1.0V.
- 2) An active-low manual-reset input.

The RS811 is available in Green SOT-143 package. It operates over an ambient temperature range of -40°C to +125°C.

Device Information (1)

PART NUMBER	PACKAGE	BODY SIZE (NOM)
RS811	SOT-143	2.90mm x 1.30mm

(1) For all available packages, see the orderable addendum at the end of the data sheet.

4 TYPICAL APPLICATION

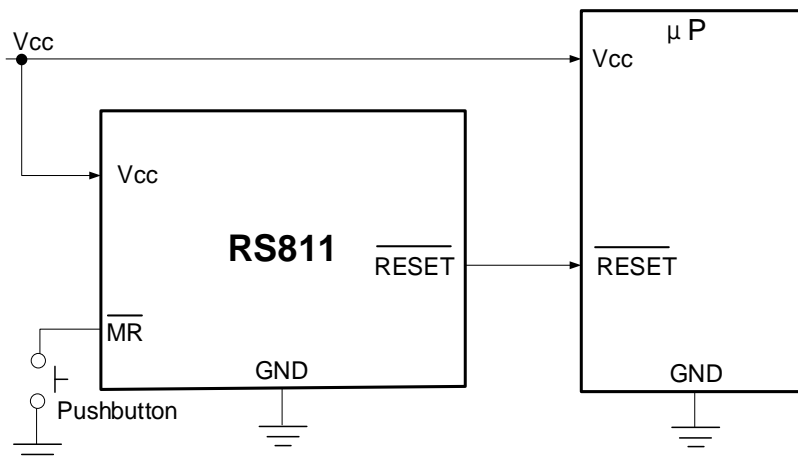

Table of Contents

1 FEATURES	1
2 APPLICATIONS	1
3 DESCRIPTIONS	1
4 TYPICAL APPLICATION	1
5 Revision History	3
6 PACKAGE/ORDERING INFORMATION ⁽¹⁾	4
7 PIN CONFIGURATIONS	5
8 Specifications	6
8.1 Absolute Maximum Ratings ⁽¹⁾	6
8.2 ESD Ratings	6
8.3 ELECTRICAL CHARACTERISTICS	7
8.4 Typical Operating Characteristics	8
9 Function Block Diagram	10
10 Detailed Description	10
10.1 Reset Output	10
10.2 Manual Reset	10
11 Applications Information	11
11.1 Ensuring a Valid RESET Output Down to $V_{CC}=0V$	11
11.2 Interfacing to μ Ps with Bidirectional Reset Pins	11
12 PACKAGE OUTLINE DIMENSIONS	12
13 TAPE AND REEL INFORMATION	13

5 Revision History

Note: Page numbers for previous revisions may differ from page numbers in the current version.

Version	Change Date	Change Item
A.1	2023/04/23	Initial version completed

6 PACKAGE/ORDERING INFORMATION ⁽¹⁾

PRODUCT	ORDERING NUMBER	TEMPERATURE RANGE	PACKAGE LEAD	PACKAGE MARKING ^(2/3)	PACKAGE OPTION
RS811	RS811-2.63YA4	-40°C ~+125°C	SOT-143	811B	Tape and Reel,3000
	RS811-2.93YA4	-40°C ~+125°C	SOT-143	811C	Tape and Reel,3000
	RS811-3.08YA4	-40°C ~+125°C	SOT-143	811D	Tape and Reel,3000
	RS811-4.00YA4	-40°C ~+125°C	SOT-143	811E	Tape and Reel,3000

NOTE:

- (1) This information is the most current data available for the designated devices. This data is subject to change without notice and revision of this document. For browser-based versions of this data sheet, refer to the right-hand navigation.
- (2) There may be additional marking, which relates to the lot trace code information(data code and vendor code), the logo or the environmental category on the device.
- (3) B, C, D, E, represents different Reset Thresholds.

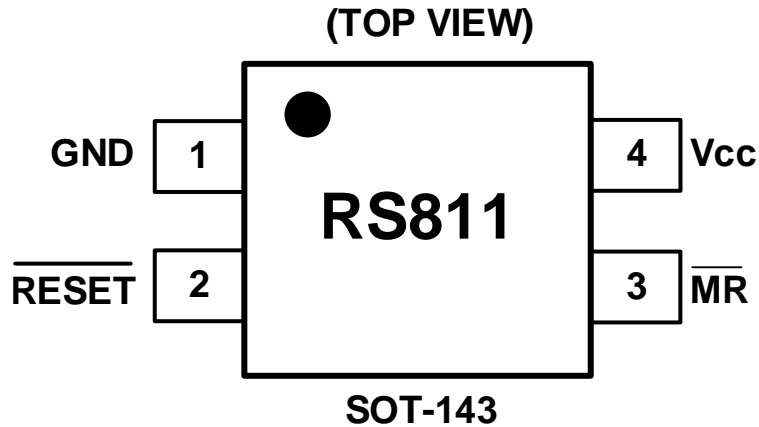
7 PIN CONFIGURATIONS

PIN DESCRIPTION

PIN	NAME	FUNCTION
SOT-143		
1	GND	Ground, reference for all signals.
2	$\overline{\text{RESET}}$	Active-Low Reset Output pulses low for 160ms when triggered, and stays low whenever V_{CC} is below the reset threshold. It remains low for 160ms after V_{CC} rises above the reset threshold or $\overline{\text{MR}}$ goes from low to high.
3	$\overline{\text{MR}}$	Manual-Reset Input triggers a reset pulse when pulled below 0.8V. This active-low input has an internal pull-up resistance. It can be driven from a TTL or CMOS logic line as well as shorted to ground with a switch.
4	V_{CC}	Power Supply Voltage that is monitored.

8 Specifications

8.1 Absolute Maximum Ratings ⁽¹⁾

over operating free-air temperature range (unless otherwise noted) ⁽¹⁾⁽²⁾

		MIN	MAX	UNIT
V _{CC}	Supply voltage range	-0.5	6.0	V
V _I	Input voltage range ⁽²⁾	-0.5	6.0	V
V _O	Voltage range applied to any output in the high-impedance or power-off state ⁽²⁾	-0.5	6.0	V
V _O	Voltage range applied to any output in the high or low state ⁽²⁾⁽³⁾	-0.5	V _{CC} +0.5	V
I _{IK}	Input clamp current	V _I <0	-20	mA
I _{OK}	Output clamp current	V _O <0	-20	mA
I _O	Continuous output current		±20	mA
	Continuous current through V _{CC} or GND		±20	mA
T _J	Junction temperature ⁽⁴⁾	-65	150	°C
T _{stg}	Storage temperature	-65	150	°C
T _A	Operating temperature	-40	125	°C

- (1) Stresses beyond those listed under *Absolute Maximum Ratings* may cause permanent damage to the device. These are stress ratings only, and functional operation of the device at these or any other conditions beyond those indicated under *Recommended Operating Conditions* is not implied. Exposure to absolute-maximum-rated conditions for extended periods may affect device reliability.
- (2) The input and output negative-voltage ratings may be exceeded if the input and output current ratings are observed.
- (3) The value of V_{CC} is provided in the *Recommended Operating Conditions table*.
- (4) The maximum power dissipation is a function of T_{J(MAX)}, R_{θJA}, and T_A. The maximum allowable power dissipation at any ambient temperature is P_D = (T_{J(MAX)} - T_A) / R_{θJA}. All numbers apply for packages soldered directly onto a PCB.

8.2 ESD Ratings

The following ESD information is provided for handling of ESD-sensitive devices in an ESD protected area only.

		VALUE	UNIT
V _(ESD) Electrostatic discharge	Human-body model (HBM), per ANSI/ESDA/JEDEC JS-001 ⁽¹⁾	±6000	V
	Machine model (MM)	±300	V

- (1) JEDEC document JEP155 states that 500 V HBM allows safe manufacturing with a standard ESD control process.



ESD SENSITIVITY CAUTION

ESD damage can range from subtle performance degradation to complete device failure. Precision integrated circuits may be more susceptible to damage because very small parametric changes could cause the device not to meet its published specifications.

8.3 ELECTRICAL CHARACTERISTICS

($V_{CC} = 1.67V$ to $5.5V$ for RS811-1.63; $V_{CC} = 2.7V$ to $5.5V$ for RS811-2.63; $V_{CC} = 3V$ to $5.5V$ for RS811-2.93; $V_{CC} = 3.16V$ to $5.5V$ for RS811-3.08; $V_{CC} = 4.1V$ to $5.5V$ for RS811-4.00; $V_{CC} = 4.51V$ to $5.5V$ for RS811-4.40; $V_{CC} = 4.77V$ to $5.5V$ for RS811-4.65; $T_A = -40^{\circ}C$ to $+125^{\circ}C$, unless otherwise noted, typical at $25^{\circ}C$.) ⁽¹⁾

PARAMETER	SYMBOL	TEST CONDITIONS	MIN	TYP	MAX	UNIT
Supply Voltage	V_{CC}		1.0		5.5	V
Supply Current	I_{SUPPLY}			2	10	μA
Reset Threshold	V_{RT}	RS811-2.63	2.56	2.63	2.7	V
		RS811-2.93	2.86	2.93	3.0	
		RS811-3.08	3.0	3.08	3.16	
		RS811-4.00	3.9	4.0	4.1	
Reset Threshold Hysteresis		RS811-2.63		12		mV
		RS811-2.93		14		
		RS811-3.08		15		
		RS811-4.00		20		
Reset Pulse Width	t_{RS}		100	160	350	ms
V_{CC} to \overline{RESET} delay	t_{RD}	$V_{CC}=3.3V$, RS811-2.93		20		μs
\overline{RESET} Output voltage	High	$I_{SOURCE} = 500\mu A$	$0.7 \times V_{CC}$			V
	Low	$I_{SINK} = 1.2mA$			0.4	
\overline{MR} Pull-Up Resistor			20	52	120	$k\Omega$
\overline{MR} Pulse Width	t_{MR}		150			ns
\overline{MR} Input Threshold	High	$V_{CC}=5.0V$	4.0			V
	Low	$V_{CC}=5.0V$			0.6	
	High	$V_{RST(MAX)} < V_{CC} < 3.6V$	$0.8 \times V_{CC}$			
	Low	$V_{RST(MAX)} < V_{CC} < 3.6V$			$0.15 \times V_{CC}$	
\overline{MR} to Reset Out Delay	t_{MD}			23	200	ns

8.4 Typical Operating Characteristics

NOTE: The graphs and tables provided following this note are a statistical summary based on a limited number of samples and are provided for informational purposes only.

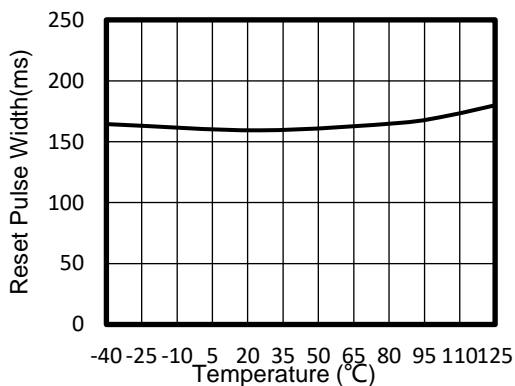

Figure 1. Reset Pulse Width vs Temperature

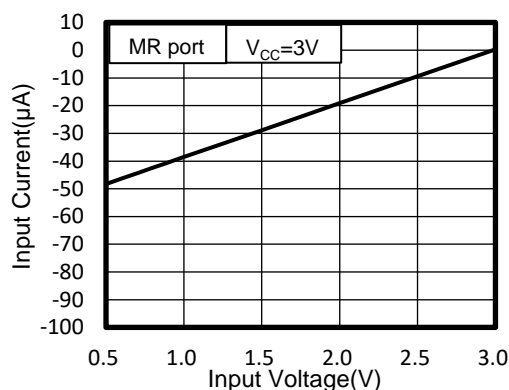

Figure 2. Input Voltage vs Input Current

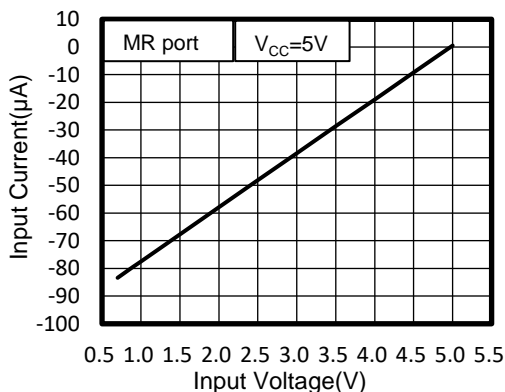

Figure 3. Input Voltage vs Input Current

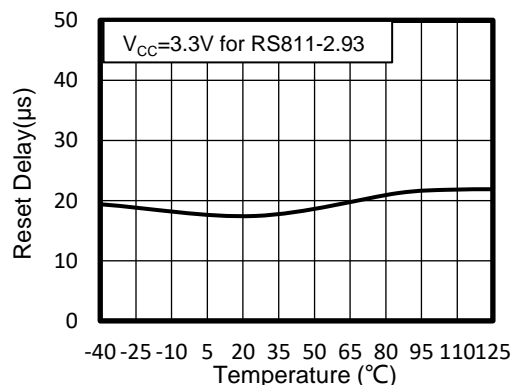

Figure 4. Reset Delay vs Temperature

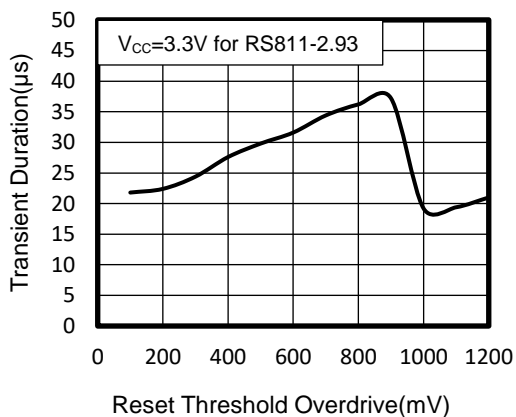

Figure 5. Transient Duration vs Reset Threshold Overdrive

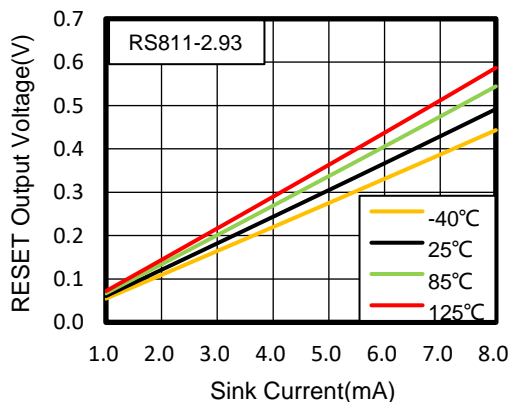

Figure 6. RESET Output Voltage vs Sink Current

Typical Operating Characteristics

NOTE: The graphs and tables provided following this note are a statistical summary based on a limited number of samples and are provided for informational purposes only.

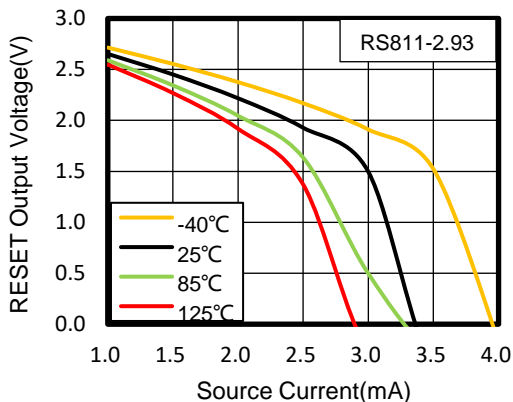

Figure 7. RESET Output Voltage vs Source Current

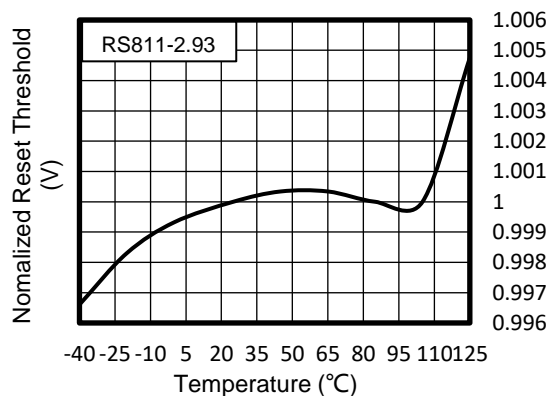

Figure 8. Normalized Reset Threshold vs Temperature

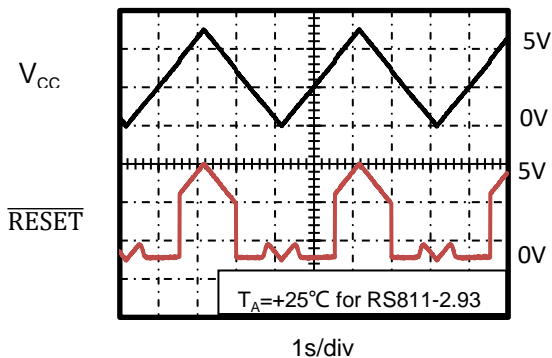

Figure 9. RESET Output Voltage vs Supply Voltage

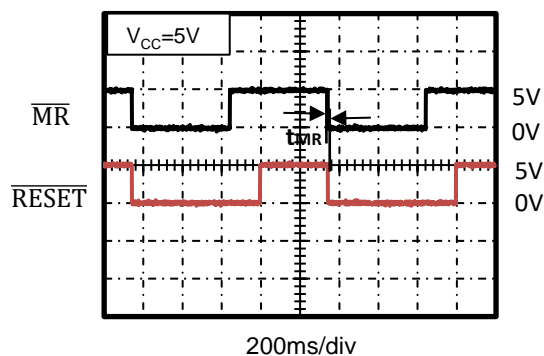

Figure 10. RESET Timing

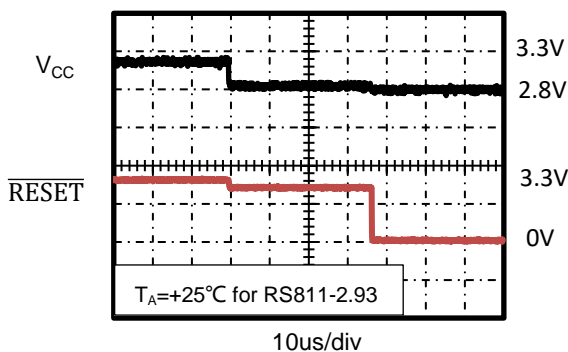
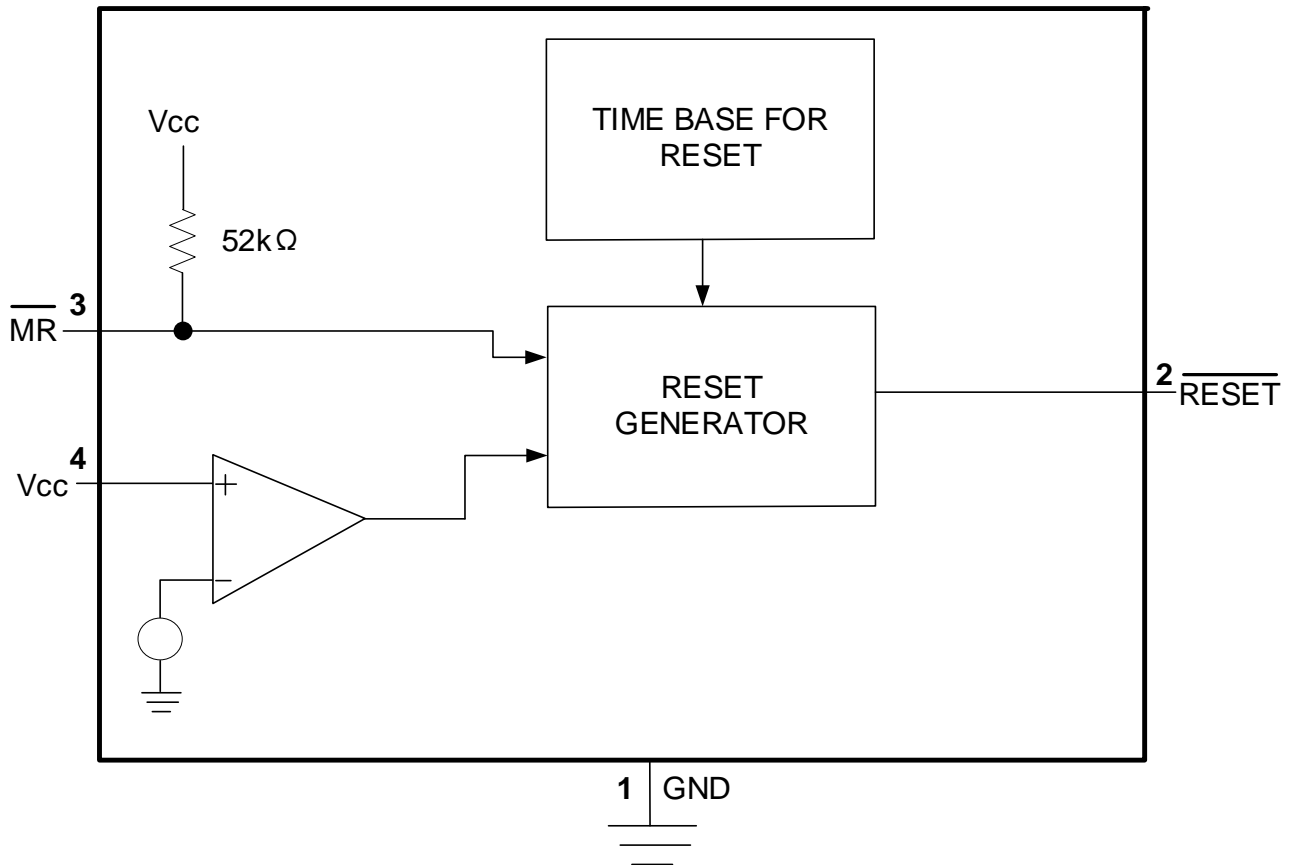

Figure 11. RESET Response Time

9 Function Block Diagram



10 Detailed Description

10.1 Reset Output

A microprocessor's (μP 's) reset input starts the μP in a known state. Whenever the μP is in an unknown state, it should be held in reset. The RS811 asserts reset during power-up and prevents code execution errors during power-down or brownout conditions.

On power-up, once V_{CC} reaches 1.0V, $\overline{\text{RESET}}$ is a guaranteed logic low of 0.4V or less. As V_{CC} rises, $\overline{\text{RESET}}$ stays low. When V_{CC} rises above the reset threshold, an internal timer releases $\overline{\text{RESET}}$ after about 160ms. $\overline{\text{RESET}}$ pulses low whenever V_{CC} dips below the reset threshold. If a brownout occurs in the middle of a previously initiated reset pulse, the pulse continues for at least another 100ms. On power-down, once V_{CC} falls below the reset threshold, $\overline{\text{RESET}}$ stays low and is guaranteed to be 0.4V or less until V_{CC} drops below 1.0V.

10.2 Manual Reset

The manual-reset input ($\overline{\text{MR}}$) allows reset to be triggered by a push-button switch. $\overline{\text{MR}}$ is TTL/CMOS logic compatible, so it can be driven by an external logic line. $\overline{\text{MR}}$ can be used to force a watchdog timeout to generate a reset pulse in the RS811. Simply connect $\overline{\text{RESET}}$ to $\overline{\text{MR}}$.

11 Applications Information

11.1 Ensuring a Valid RESET Output Down to $V_{CC}=0V$

When V_{CC} falls down below 1V, the RS811 \overline{RESET} output no longer sinks current, it becomes an open circuit. High-impedance CMOS logic inputs can drift to undetermined voltages if left un-driven. If a pull-down resistor is added to the \overline{RESET} pin, as shown in Figure 12, any stray charge or leakage currents will be drained to ground, holding \overline{RESET} low. Resistor value (R1) is not critical. It should be about 100K Ω , large enough not to load \overline{RESET} and small enough to pull \overline{RESET} to ground.

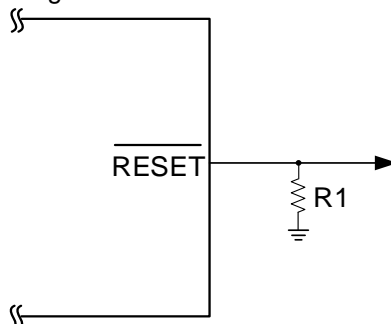

Figure 12. RESET Valid to Ground Circuit

11.2 Interfacing to μP s with Bidirectional Reset Pins

μP s with bidirectional reset pins, can contend with the RS811 \overline{RESET} output. If, for example, the \overline{RESET} output is driven high and the μP wants to pull it low, indeterminate logic levels may result. To correct this, connect a 4.7K Ω resistor between the \overline{RESET} output and the μP reset I/O, as in Figure 13. Buffer the \overline{RESET} output to other system components.

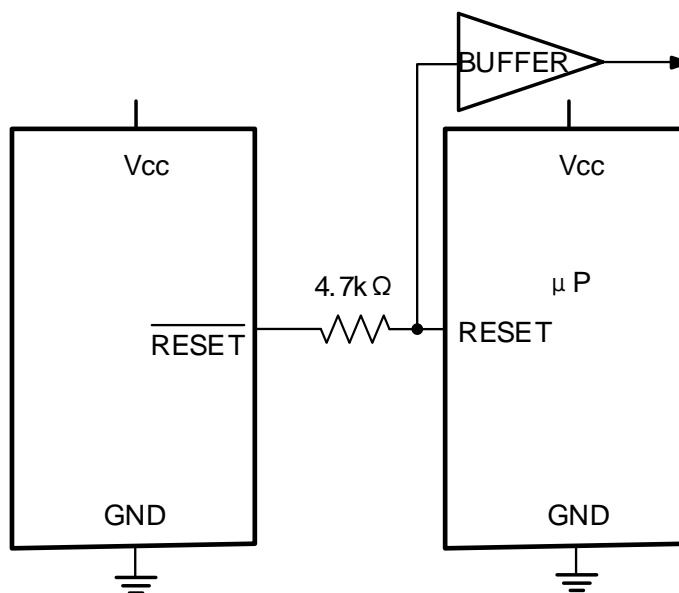
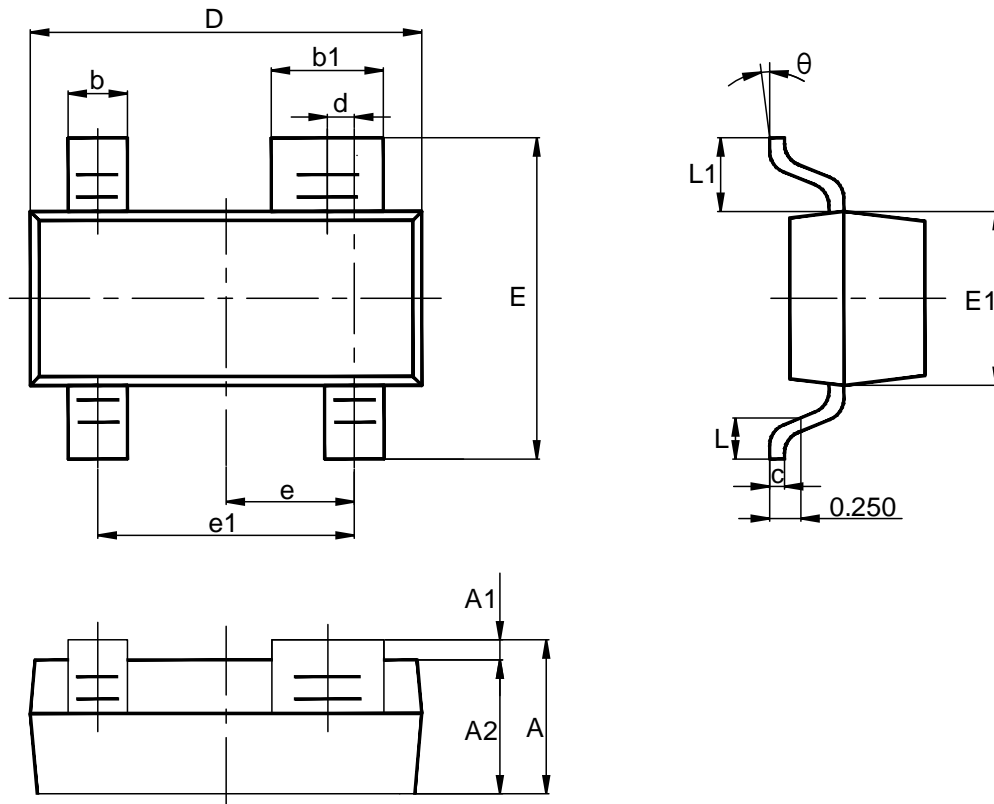

Figure 13. Buffered \overline{RESET} to other system components

12 PACKAGE OUTLINE DIMENSIONS

SOT-143



Symbol	Dimensions In Millimeters		Dimensions In Inches	
	Min	Max	Min	Max
A	0.900	1.150	0.035	0.045
A1	0.000	0.100	0.000	0.004
A2	0.900	1.050	0.035	0.041
b	0.300	0.500	0.012	0.020
b1	0.750	0.900	0.030	0.035
c	0.080	0.150	0.003	0.006
D	2.800	3.000	0.110	0.118
d	0.200 (TYP)		0.008 (TYP)	
E	2.250	2.550	0.089	0.100
E1	1.200	1.400	0.047	0.055
e	0.950 (TYP)		0.037 (TYP)	
e1	1.800	2.000	0.071	0.079
L	0.300	0.500	0.012	0.020
L1	0.550 (REF)		0.022 (REF)	
θ	0°	8°	0°	8°

NOTE:

- A. All linear dimension is in millimeters.
- B. This drawing is subject to change without notice.
- C. Body dimensions do not include mold flash or protrusion. Mold flash and protrusion shall not exceed 0.15 per side.
- D. REF: Reference Dimension, usually without tolerance, for information purposes only.

13 TAPE AND REEL INFORMATION

REEL DIMENSIONS

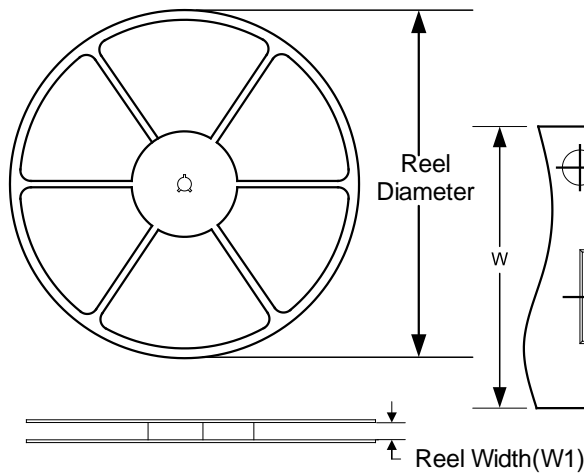

TAPE DIMENSION

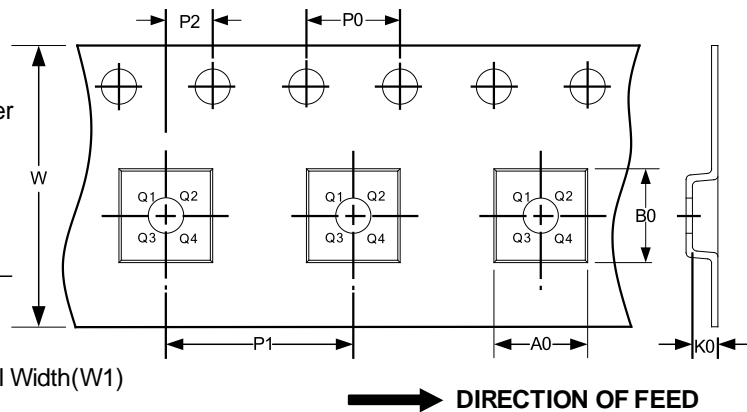

NOTE: The picture is only for reference. Please make the object as the standard.

KEY PARAMETER LIST OF TAPE AND REEL

Package Type	Reel Diameter	Reel Width (mm)	A0 (mm)	B0 (mm)	K0 (mm)	P0 (mm)	P1 (mm)	P2 (mm)	W (mm)	Pin1 Quadrant
SOT-143	7"	8.30	3.19	2.80	1.31	4.0	4.0	2.0	8.0	Q3

NOTE:

1. All dimensions are nominal.
2. Plastic or metal protrusions of 0.15mm maximum per side are not included.

IMPORTANT NOTICE AND DISCLAIMER

Jiangsu Runic Technology Co., Ltd. will accurately and reliably provide technical and reliability data (including data sheets), design resources (including reference designs), application or other design advice, WEB tools, safety information and other resources, without warranty of any defect, and will not make any express or implied warranty, including but not limited to the warranty of merchantability Implied warranty that it is suitable for a specific purpose or does not infringe the intellectual property rights of any third party.

These resources are intended for skilled developers designing with Runic products You will be solely responsible for: (1) Selecting the appropriate products for your application; (2) Designing, validating and testing your application; (3) Ensuring your application meets applicable standards and any other safety, security or other requirements; (4) Runic and the Runic logo are registered trademarks of Runic Incorporated. All trademarks are the property of their respective owners; (5) For change details, review the revision history included in any revised document. The resources are subject to change without notice. Our company will not be liable for the use of this product and the infringement of patents or third-party intellectual property rights due to its use.