



Description

DW03C has built-in high-precision voltage detection circuit and delay circuit, which can realize overcharge, overdischarge and overcurrent protection of the battery by detecting the voltage and current of the battery. The protection circuit is suitable for a single lithium ion/lithium polymer rechargeable battery.

Features

- High Precision Voltage Detection Function:

1. Overcharge Protection Voltage	4.300V	Accuracy: $\pm 25\text{mV}$
2. Overcharge Release Voltage	4.100V	Accuracy: $\pm 50\text{mV}$
3. Overdischarge Protection Voltage	2.400V	Accuracy: $\pm 100\text{mV}$
4. Overdischarge Release Voltage	3.000V	Accuracy: $\pm 100\text{mV}$
5. Discharge Overcurrent Detection	3.6A	Accuracy: $\pm 25\%$
6. Short Circuit Current Detection	12.0A	Accuracy: $\pm 30\%$
7. Charging Overcurrent Detection	2.5A	Accuracy: $\pm 25\%$

- Internal Detection Delay Time:

1. Overcharge Protection Delay	1.0S	Accuracy: $\pm 50\%$
2. Overdischarge Protection Delay	64mS	Accuracy: $\pm 50\%$
3. Delay of Discharge Overcurrent	10mS	Accuracy: $\pm 50\%$
4. Delay of Charge Overcurrent	10mS	Accuracy: $\pm 50\%$

- Charger Detection and Load Detection Function

● Function of Charging 0V Battery	Allow
● Dormancy Function	No
● Conditions for Relieving Discharge Overcurrent	Disconnect The Load
● The Release Voltage of Discharge Overcurrent State	V_{RIOV}

- Low Current Consumption

1. At Work	1.0 μA (Typ.) ($T_a=25^\circ\text{C}$)
2. Overdischarge	0.5 μA (Typ.) ($T_a=25^\circ\text{C}$)

- On-Resistance of internal Power N-MOSFET: 60m Ω

- Lead-Free and Halogen-Free

- Operating Temperature Range: $-40^\circ\text{C}\sim+85^\circ\text{C}$

- Available Package: SOT-23-5

Applications

- Protection IC for One-Cell Lithium-Ion /Lithium-Polymer Battery Pack

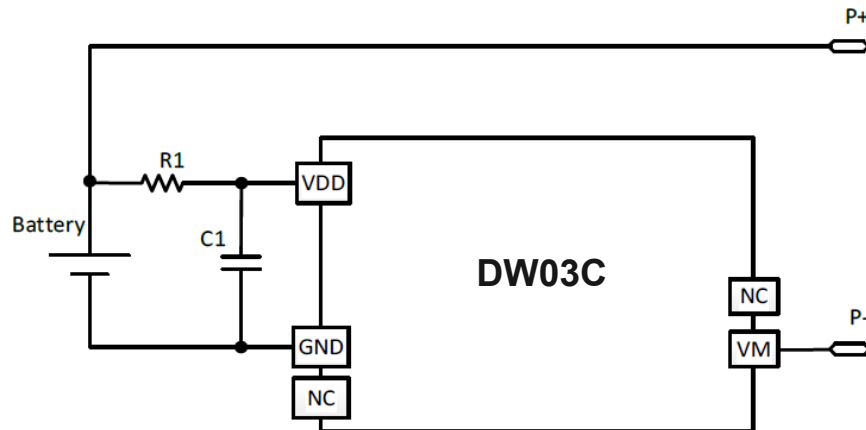
Typical Application Circuit

Device Identification	Min.	Typ.	Max.	Unit
R1	510	1000	1500	Ω
C1	0.047	0.1	0.22	μF

Note :

1. The above parameters may be changed without notice.
2. The schematic diagram and parameters of IC are not used as the basis to ensure the circuit to work. Please make field measurement on the actual application circuit before setting the parameters.

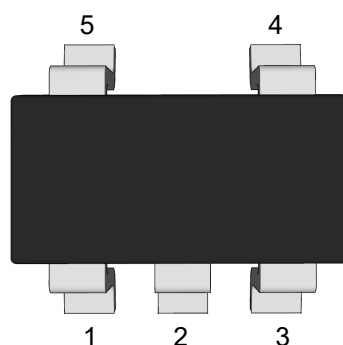
Pin Distribution
SOT-23-5

Functional Pin Description

Pin NO.	Symbol	Pin Description
1,5	NC	Not Connected
2	GND	Ground Pin
3	VDD	Power Supply
4	VM	The charging and discharging current detection terminal is linked with the charger load or the load

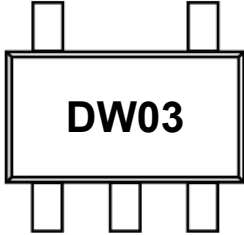

Ordering Information

Orderable Device	Package	Reel (inch)	Package Qty (PCS)	Eco Plan <small>Note</small>	MSL Level	Marking Code
DW03C	SOT-23-5	7	3000	RoHS & Green	MSL3	

Note:
 RoHS: PJ defines "RoHS" to mean semiconductor products that are compliant with the current EU RoHS requirements for all 10 RoHS substances, including the requirement that RoHS substance do not exceed 0.1% by weight in homogeneous materials.
 Green: PJ defines "Green" to mean Halogen-Free and Antimony-Free.

Product List

1. Detection Voltage Sheet

Device Name	$R_{DS(on)}$	Overcharge Protection Voltage V_{OC}	Overcharge Release Voltage V_{OCR}	Overdischarge Protection Voltage V_{OD}	Overdischarge Release Voltage V_{ODR}	Discharge OverCurrent Detection I_{DI}	Short Circuit Current Detection I_{SHORT}	Charging OverCurrent Detection I_{CI}
DW03C	33mΩ	4.300V	4.100V	2.400V	3.000V	3.6A	12A	2.5A

2. Product Function Sheet

Device Name	Function of Charging 0V Battery	The Release Condition of Discharge Overcurrent State	The Release Voltage of Discharge Overcurrent State	Overcharge Self-recovery Function	Dormancy Function
DW03C	Allow	断开负载	V_{RIOV}	有	无

3. Delay Time

Device Name	Overcharge Protection Delay T_{OC}	Overdischarge Protection Delay T_{OD}	Delay of Discharge Overcurrent T_{DI}	Delay of Charge Overcurrent T_{CI}	Short Circuit Delay T_{SHORT}
DW03C	1000ms	64ms	10ms	10ms	250μs

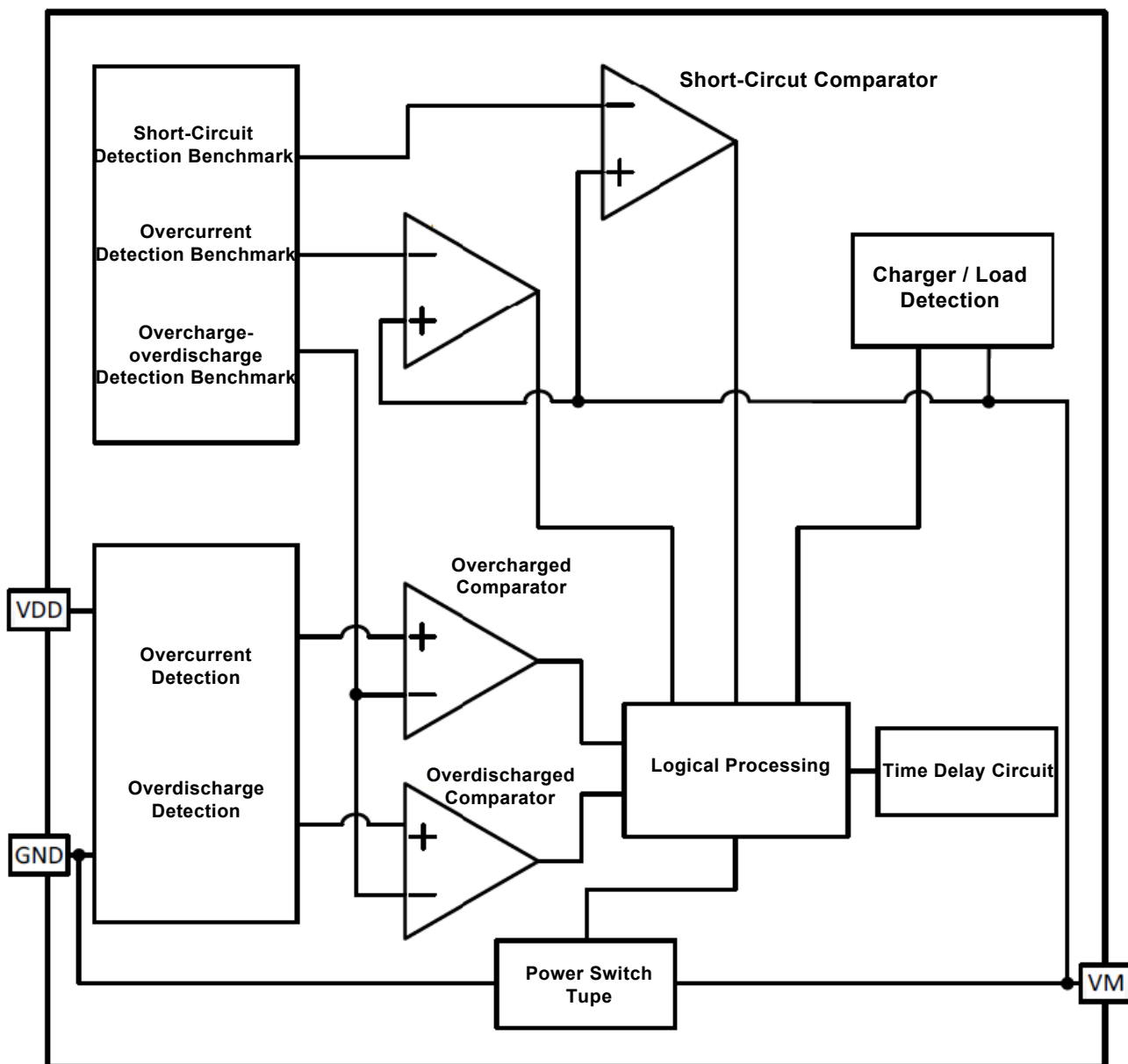
Block Diagram

**Absolute Maximum Ratings** ^{Note}

(T_A=25°C , unless otherwise noted.)

Parameter	Symbol	Rating	Unit
Input Voltage Between VDD and GND	VDD	-0.3 ~6	V
VM Pin Output Voltage	V _{VM}	-6 ~10	V
Operating Ambient Temperature Range	T _{OPR}	-40 ~ 85	°C
Storage Temperature Range	T _{STG}	-55 ~ 125	°C
ESD(HBM State)	V _{ESD(HBM)}	4000	V

Note :

The applied voltage exceeds the absolute maximum rating, which may cause irreversible damage to the chip.



Electrical Characteristics

(T_A=25°C , unless otherwise noted.)

Parameter	Symbol	Test Conditions	Min.	Typ.	Max.	Unit
Normal working current	I _{OPE}	VDD=3.6V, V _{VM} =0V	0.42	1.0	2.0	μA
Consume current during overdischarge	I _{OPEd}	VDD=2.0V, V _{VM} floating	--	0.5	1.0	μA
Overcharge Protection Voltage	V _{OC}	VDD=3.5→4.8V	4.275	4.300	4.325	V
Overcharge Release Voltage	V _{OCR}	VDD=4.8→3.5V	4.050	4.100	4.150	V
Overdischarge Protection Voltage	V _{OD}	VDD=3.5→2.0V	2.300	2.400	2.500	V
Overdischarge Release Voltage	V _{ODR}	VDD=2.0→3.5V	2.900	3.000	3.100	V
Discharge Overcurrent Release Voltage	V _{RIOV}		VDD-1.2	VDD-0.8	VDD-0.5	V
Discharge OverCurrent Detection	I _{DI}	VDD=3.6V	2.7	3.6	4.5	A
Short Circuit Current Detection	I _{SHORT}	VDD=3.6V	8.4	12	15.6	A
Charging OverCurrent Detection	I _{CI}	VDD=3.6V	1.87	2.5	3.13	A
Overcharge Protection Delay	T _{OC}	VDD=3.5→4.8V	500	1000	1500	ms
Overdischarge Protection Delay	T _{OD}	VDD=3.5→2.0V	32	64	96	ms
Delay of Discharge Overcurrent	T _{DI}	VDD=3.6V	5	10	15	ms
Delay of Charge Overcurrent	T _{CI}	VDD=3.6V	5	10	15	ms
Short Circuit Delay	T _{SHORT}	VDD=3.6V	100	250	400	μs
Resistance Between VDD and VM	R _{CMD}	VDD=2V, V _{VM} =0V	750	1500	3000	kΩ
Resistance Between VDD and GND	R _{VMS}	VDD=3.6V, V _{VM} =1.0V	10	20	30	kΩ
On-Resistance Of internal Power N-MOSFET	R _{SS(ON)}	VDD=3.6V, I _{VM} =0.1A	--	60	--	mΩ
0V Charging, Charger Starting Voltage	V _{0CH}	Allow charging to 0V battery	0.0	1.5	2.0	V



Electrical Characteristics

(T_A=20°C~60°C , unless otherwise noted.)

Parameter	Symbol	Test Conditions	Min.	Typ.	Max.	Unit
Normal working current	I _{OPE}	VDD=3.6V, V _{VM} =0V	0.42	1.0	2.0	μA
Consume current during overdischarge	I _{OPEd}	VDD=2.0V, V _{VM} floating	--	0.5	1.0	μA
Overcharge Protection Voltage	V _{OC}	VDD=3.5→4.8V	4.250	4.300	4.350	V
Overcharge Release Voltage	V _{OCR}	VDD=4.8→3.5V	4.000	4.100	4.200	V
Overdischarge Protection Voltage	V _{OD}	VDD=3.5→2.0V	2.200	2.400	2.600	V
Overdischarge Release Voltage	V _{ODR}	VDD=2.0→3.5V	2.800	3.000	3.200	V
Discharge Overcurrent Release Voltage	V _{RIOV}		VDD-1.3	VDD-0.8	VDD-0.4	V
Discharge OverCurrent Detection	I _{DI}	VDD=3.6V	1.8	3.6	5.4	A
Charging OverCurrent Detection	I _{CI}	VDD=3.6V	1.25	2.5	3.75	A
Overcharge Protection Delay	T _{OC}	VDD=3.5→4.8V	300	1000	1700	ms
Overdischarge Protection Delay	T _{OD}	VDD=3.5→2.0V	19.2	64	108.8	ms
Delay of Discharge Overcurrent	T _{DI}	VDD=3.6V	3	10	17	ms
Delay of Charge Overcurrent	T _{CI}	VDD=3.6V	3	10	17	ms
Short Circuit Delay	T _{SHORT}	VDD=3.6V	75	250	500	μs
Resistance Between VDD and VM	R _{CMD}	VDD=2V, V _{VM} =0V	500	1500	6000	kΩ
Resistance Between VDD and GND	R _{VMS}	VDD=3.6V, V _{VM} =1.0V	7	20	40	kΩ
On-Resistance Of internal Power N-MOSFET	R _{SS(ON)}	VDD=3.6V, I _{VM} =0.1A	--	60	--	mΩ
0V Charging, Charger Starting Voltage	V _{0CH}	Allow charging to 0V battery	0.0	1.5	2.5	V

Note :

The scieinine is not caried out under the conditions of hig temperature and low temperature,so only the inital votape of the esign specs in this temperature rane is guaranteed

Sequence Chart

1、Overcharge protection and over-current protection

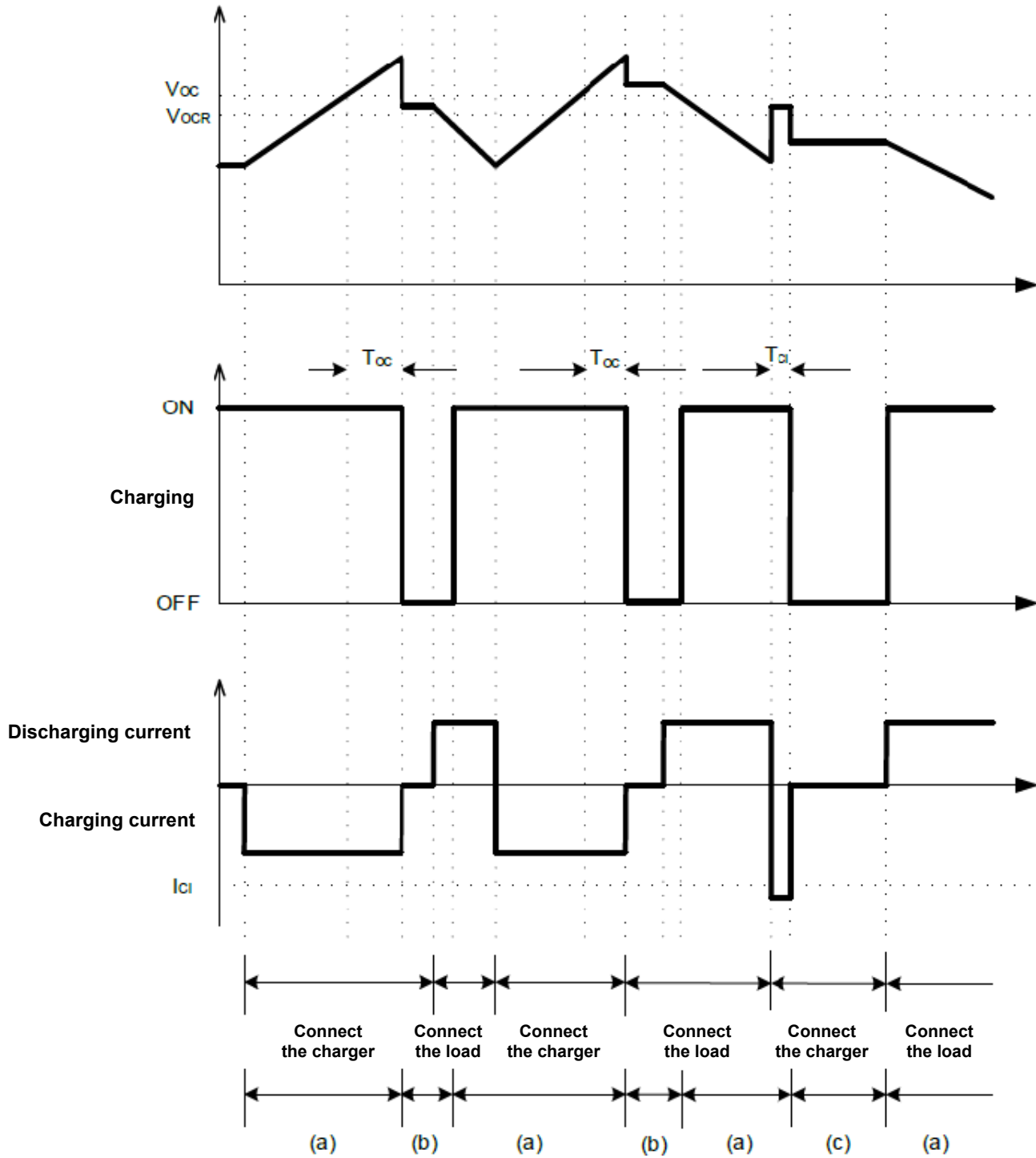

- (a) Normal operating state
- (b) Overcharged state
- (c) charging overcurrent state



2、Overdischarge protection and discharge overcurrent protection

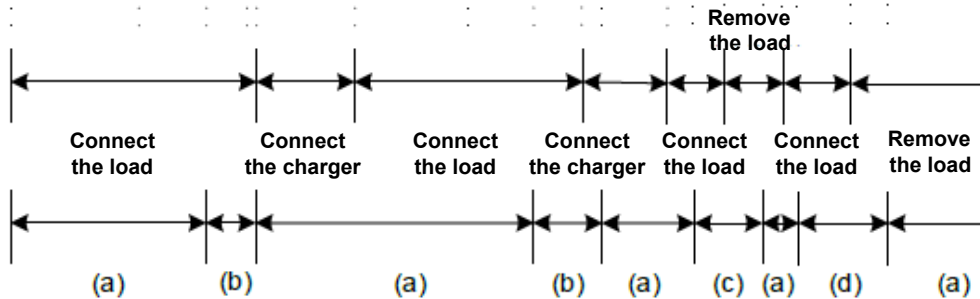
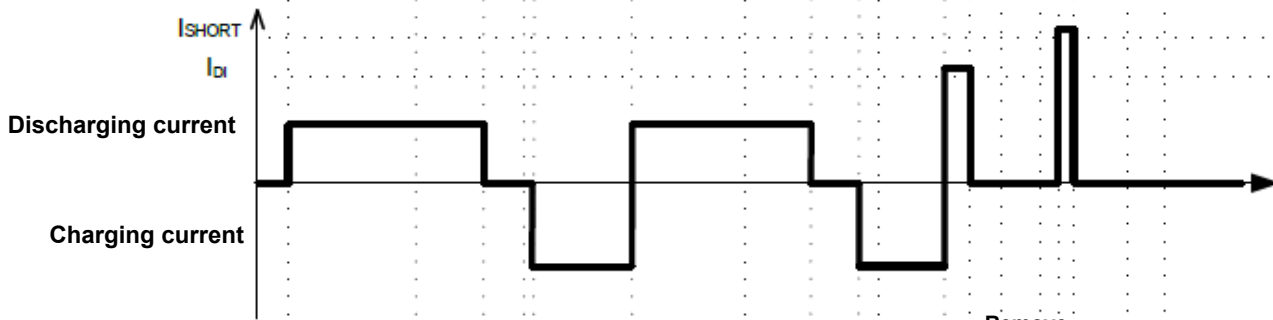
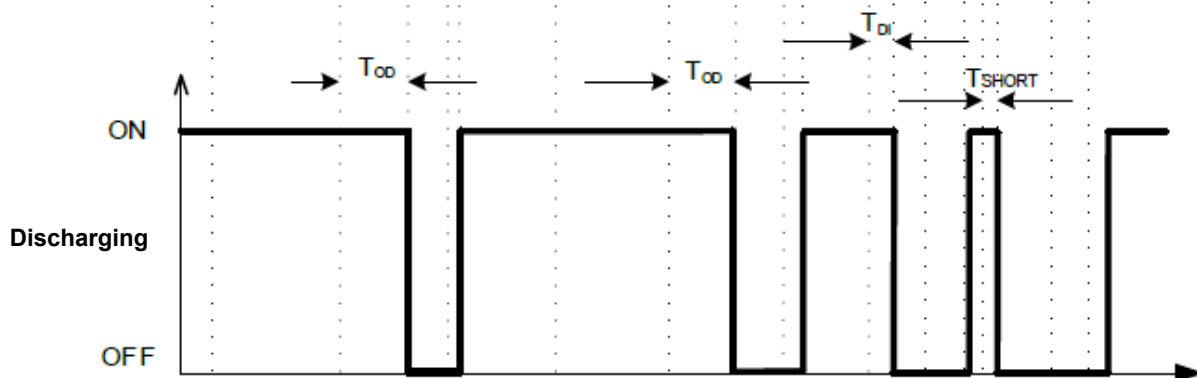
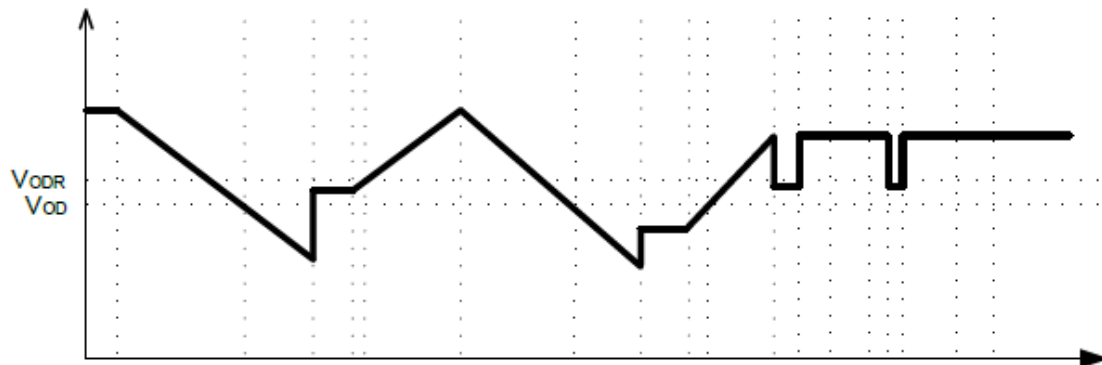

- (a) Normal working state
- (b) Overdischarge state
- (c) Discharge overcurrent state
- (d) load short-circuit state



Function Description

1. Normal Operating State

This IC continuously detects the battery voltage connected between the VDD and GND terminals, as well as the current flowing between the VM and GND terminals, to control charge and discharge. When the battery voltage is above the overdischarge protection voltage (V_{OD}) and below the overcharge protection voltage (V_{OC}), and the current flowing through the VM terminal to GND is between the charge overcurrent protection threshold (I_{CI}) and discharge overcurrent protection threshold (I_{DI}), the internal MOSFET of the IC is switched on. This state is called "normal working state". In this state, the MOSFET can be charged and discharged normally.

2. Overcharge State

When during the charging process under normal conditions, when the battery voltage is higher than the overcharge detection voltage (V_{OC}), and the duration reaches the overcharge voltage detection delay time (T_{OC}) or longer, the internal MOSFET of IC will turn off and stop charging, this situation is called overcharge voltage protection. The overcharge state can be lifted under the following two conditions:

(1). $VM < V_{LD}$, when the battery voltage is lowered below the overcharge release voltage (V_{OCR}), the overcharge state will be released.

(2). $VM > V_{LD}$, when the battery voltage is reduced to the overcharge protection voltage (V_{OC}) below, the overcharge state is lifted and returned to the normal working state, this function is called the load detection function.

Here (V_{LD}) = $I_{DI} * R_{SS(ON)}$, is the load detection voltage set inside the IC.

3. Overdischarge State

After the battery voltage drops below V_{OD} and the well continues T_{OD} for a period of time, the internal MOSFET of IC will turn off and stop discharging, which is called the overdischarge state. When the MOSFET inside the IC is turned off, the VM will be pulled up to VDD by the internal pull-up resistor R_{VMD} , and the IC power consumption will be reduced to I_{OPED} .

After entering the overdischarge state, to remove the overdischarge state and return to the normal state, there are several situations:

(1) Connect the charger, if $VM < 0V$ (typical value), when the battery voltage is higher than the overdischarge protection voltage (V_{OD}), the overdischarge state is lifted and restored to the normal working state, this function is called the charger detection function.

(2) Connect the charger, if $VM > 0V$ (typical value), when the battery voltage is higher than the overdischarge release voltage (V_{ODR}), the overdischarge state is lifted and restored to the normal working state.

(3) When the charger is not connected, when the battery voltage is higher than the overdischarge release voltage (V_{ODR}), the overdischarge state is released and returned to the normal working state, that is, "no sleep function".

4. Discharge Overcurrent State

In the normal working state of the battery, the IC continuously detects the discharge current through the VM terminal voltage. If the discharge current exceeds the discharge current Limiting value (I_{DI}), and this state lasts longer than the discharge overcurrent Protection Delay time (T_{DI}), the internal MOSFET of IC will turn off and stop discharging. This state is called the discharge overcurrent state. If the discharge current exceeds the short-circuit protection current value, and this state lasts longer than the load short-circuit protection delay time (T_{SHORT}), the MOSFET inside the IC will turn off and stop discharging. This state is called the "load short-circuit state".

Discharge overcurrent state release condition "disconnect load" and discharge overcurrent state release voltage " V_{RIOV} "

In the discharge overcurrent state, the VM terminal inside the chip and the GND terminal can be connected through the R_{VMS} resistor. However, during the connection to the load, the VM terminal voltage changes to the VDD terminal voltage due to the connection to the load. If the connection to the load is disconnected, the VM terminal reverts to the GND terminal voltage. When the VM terminal voltage drops below V_{RIOV} , the discharge overcurrent state can be lifted.

**5. Charge Overcurrent Protection**

For a battery in normal working condition, if the current value flowing through GND to VM exceeds the charge overcurrent protection value (I_{CI}) during charging, and the state lasts longer than the charge overcurrent protection Delay time (T_{CI}), the internal MOSFET of IC will turn off and stop charging. This state is called charging overcurrent state. After entering the state of charge overcurrent detection, if disconnect the charger to make the flow through GND to VM, when the current of the VM terminal is lower than the overcurrent protection value (I_{CI}), the charging overcurrent state is removed and returned to the normal working state.

6. Charging Function to 0V Battery(Allowed)

This function is used to recharge the battery that has self-discharged to 0V. When the charger voltage connected between the positive battery (P+) and the negative battery (P-) is higher than the charger starting voltage (V_{OCH}) to charge the 0V battery, the IC internal charge control MOSFET will switch on and start charging. When the battery voltage is higher than the overdischarge protection voltage (V_{OD}), the IC enters the normal working state.

Note: Please ask the battery supplier to confirm whether the purchased battery has the "allow charging to the 0V battery" function or the "do not charge to the 0V battery" function".

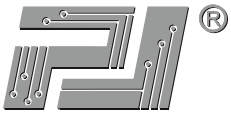

DW03C

One Cell Lithium-ion/Polymer Battery Protection IC

Package Outline

SOT-23-5

Dimensions in mm

