

Features

- N-Channel, *Low $R_{DS(on)}$ @ $V_{GS}=10V$*
- *10V Logic Level Control*
- *100% UIS Tested*
- *Pb-Free, RoHS Compliant*

$V_{(BR)DSS}$	$R_{DS(ON)}$ Typ	I_D Max
150V	27m Ω @ 10V	35A
	26m Ω @ 12V	

Applications

- Primary Side Switch
- Load Switch
- *Optimized for Power Management Applications for Portable Products, such as H-bridge, Inverters Car Charger and Others*

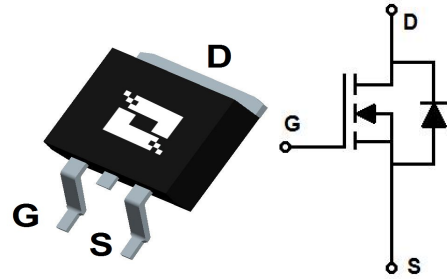
TO-263
Order Information

Product	Package	Marking	Packing
DWY35N15H	TO-263	35N15H	800PCS/Reel

Absolute Maximum Ratings

Stresses exceeding Maximum Ratings may damage the device. Maximum Ratings are stress ratings only. Functional operation above the Recommended Operating Conditions is not implied. Extended exposure to stresses above the Recommended Operating Conditions may affect device reliability.

Symbol	Parameter	Rating	Unit
Common Ratings ($T_j=25^\circ\text{C}$ Unless Otherwise Noted)			
V_{GS}	Gate-Source Voltage	± 20	V
$V_{(BR)DSS}$	Drain-Source Breakdown Voltage	150	V
T_J	Maximum Junction Temperature	150	$^\circ\text{C}$
T_{STG}	Storage Temperature Range	-50 to 150	$^\circ\text{C}$
Mounted on Large Heat Sink			
I_{DM}	Pulse Drain Current Tested ^①	$T_C=25^\circ\text{C}$	100 A
I_D	Continuous Drain Current($V_{GS}=4.5V$)	$T_C=25^\circ\text{C}$	35 A
		$T_C=70^\circ\text{C}$	28 A
P_D	Maximum Power Dissipation	$T_C=25^\circ\text{C}$	83 W
EAS	Avalanche energy, single pulsed ^②		216.6 mJ
$R_{\theta JC}$	Thermal Resistance-Junction to Case		1.5 $^\circ\text{C/W}$

Symbol	Parameter	Condition	Min	Typ	Max	Unit
Static Electrical Characteristics @ T_J = 25°C (unless otherwise stated)						
V _{(BR)DSS}	Drain-Source Breakdown Voltage	V _{GS} =0V I _D =250μA	150	--	--	V
I _{DSS}	Zero Gate Voltage Drain Current(T _C =25°C)	V _{DS} =120V, V _{GS} =0V	--	--	1	μA
	Zero Gate Voltage Drain Current(T _C =125°C)	V _{DS} =120V, V _{GS} =0V	--	--	100	uA
I _{GSS}	Gate-Body Leakage Current	V _{GS} =±20V, V _{DS} =0V	--	--	±100	nA
V _{GS(TH)}	Gate Threshold Voltage	V _{DS} =V _{GS} , I _D =250μA	2.5	3.4	4.5	V
R _{DS(ON)}	Drain-Source On-State Resistance ^③	V _{GS} =10V, I _D =18A	--	27	34	mΩ
R _{DS(ON)}	Drain-Source On-State Resistance ^③	V _{GS} =12V, I _D =18A	--	26	33	mΩ
Dynamic Electrical Characteristics @ T_J = 25°C (unless otherwise stated)						
C _{iss}	Input Capacitance	V _{DS} =75V, V _{GS} =0V, f=1MHz	--	2490	--	pF
C _{oss}	Output Capacitance		--	130	--	pF
C _{rss}	Reverse Transfer Capacitance		--	80	--	pF
R _g	Gate Resistance	f=1MHz	--	5.8	--	Ω
Q _g	Total Gate Charge	V _{DS} =75V I _D =10A, V _{GS} =10V	--	51.5	--	nC
Q _{gs}	Gate Source Charge		--	12	--	nC
Q _{gd}	Gate Drain Charge		--	19.5	--	nC
Switching Characteristics @ T_J = 25°C (unless otherwise stated)						
t _{d(on)}	Turn on Delay Time	V _{DD} =75V, I _D =10A, R _G =3.3Ω, V _{GS} =10V	--	22	--	ns
t _r	Turn on Rise Time		--	15	--	ns
t _{d(off)}	Turn Off Delay Time		--	34	--	ns
t _f	Turn Off Fall Time		--	12	--	ns
Source Drain Diode Characteristics @ T_J = 25°C (unless otherwise stated)						
t _{rr}	Reverse Recovery Time	I _{SD} =8A, V _{GS} =0V di/dt=100A/μs	--	78	--	nS
Q _{rr}	Reverse Recovery Charge		--	245	--	nC
V _{SD}	Forward on voltage ^②	I _{SD} =18A, V _{GS} =0V	--	0.82	1.2	V

Notes: ① Pulse width limited by maximum allowable junction temperature

② Limited by T_{Jmax}, starting T_J = 25°C, L = 0.3mH, R_G = 25Ω, I_{AS} = 3.8 A, V_{GS} = 10V. Part not recommended for use above this value

③ Pulse width ≤ 300μs; duty cycle ≤ 2%.

Typical Characteristics

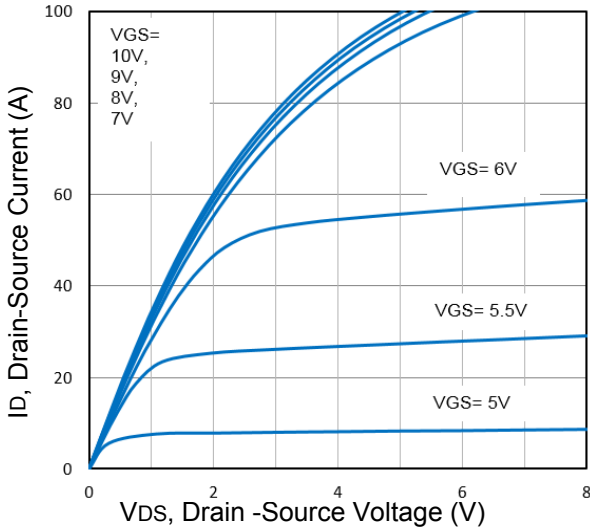

Fig1. Typical Output Characteristics

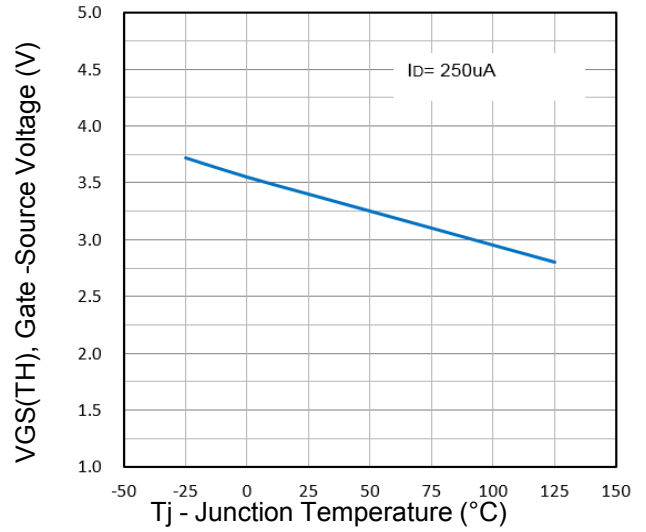

Fig2. Normalized Threshold Voltage Vs. Temperature

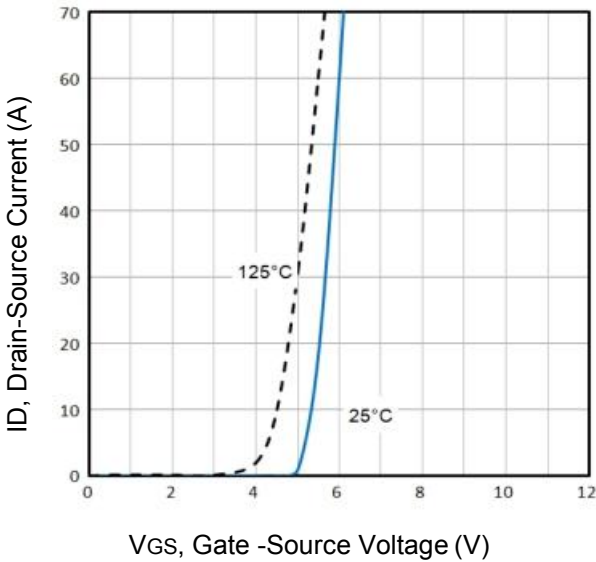

Fig3. Typical Transfer Characteristics

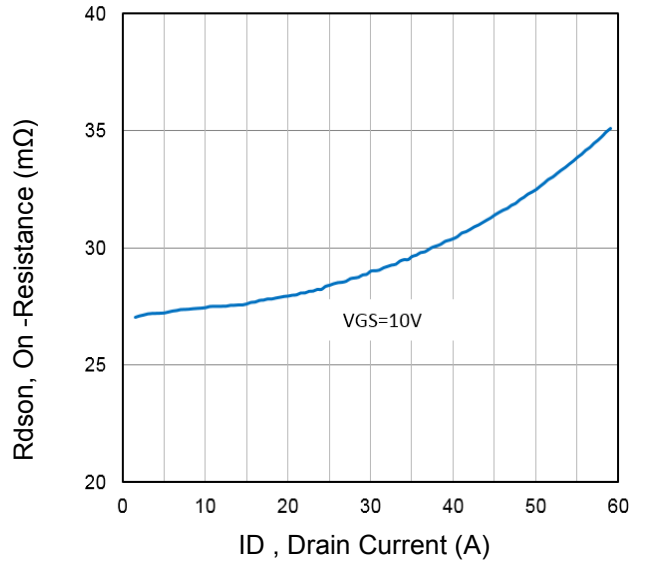

Fig4. On-Resistance vs. Drain Current and Gate Voltage

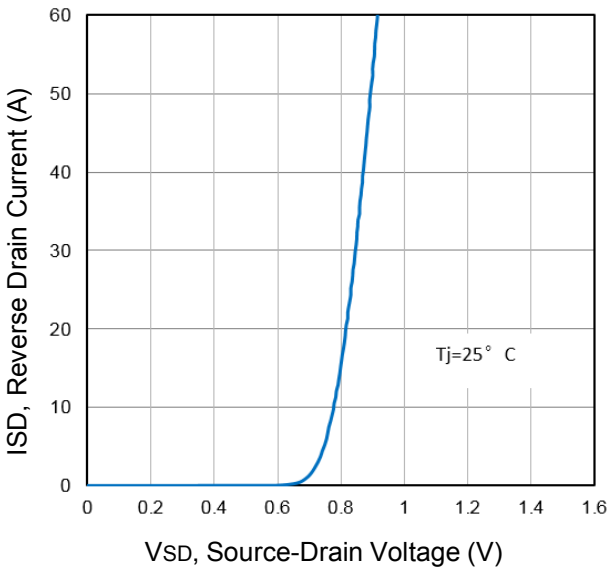

Fig5. Typical Source-Drain Diode Forward Voltage

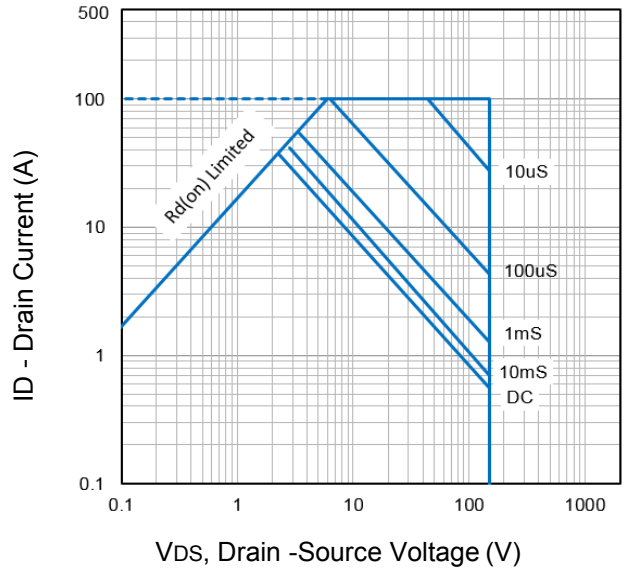

Fig6. Maximum Safe Operating Area

Typical Characteristics

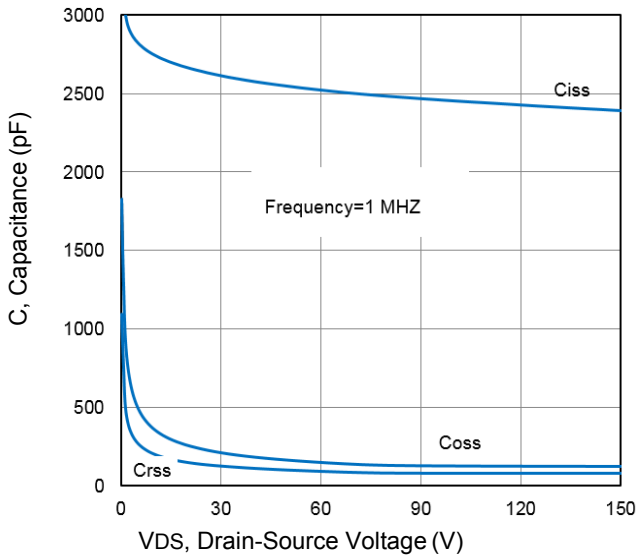

Fig7. Typical Capacitance Vs. Drain-Source Voltage

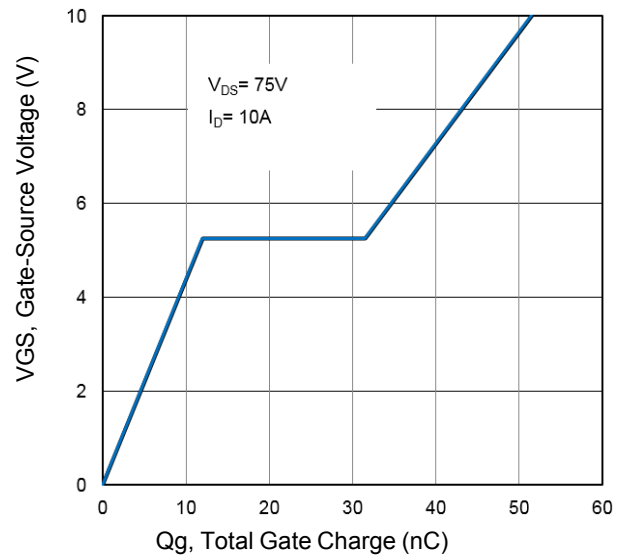

Fig8. Typical Gate Charge Vs. Gate-Source Voltage

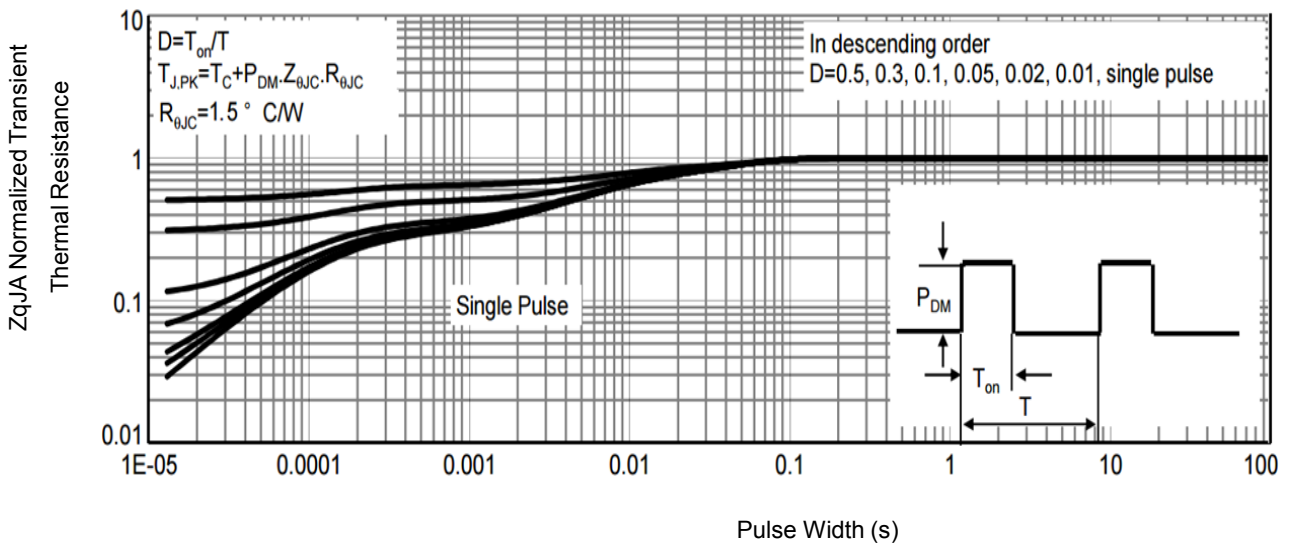

Fig9. Normalized Maximum Transient Thermal Impedance

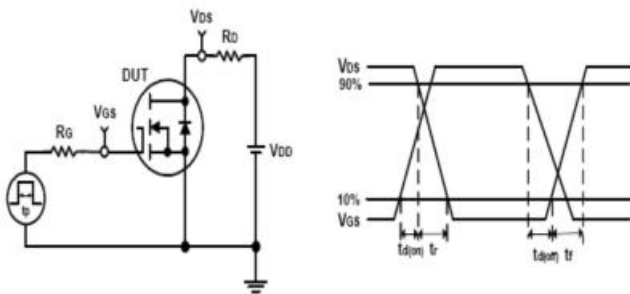

Fig10. Switching Time Test Circuit and waveforms

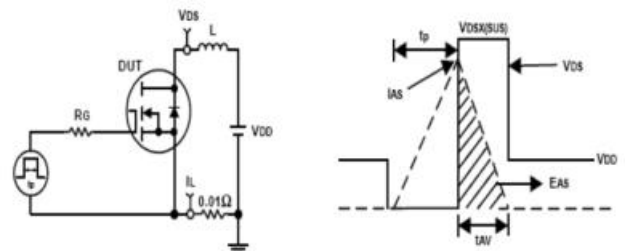
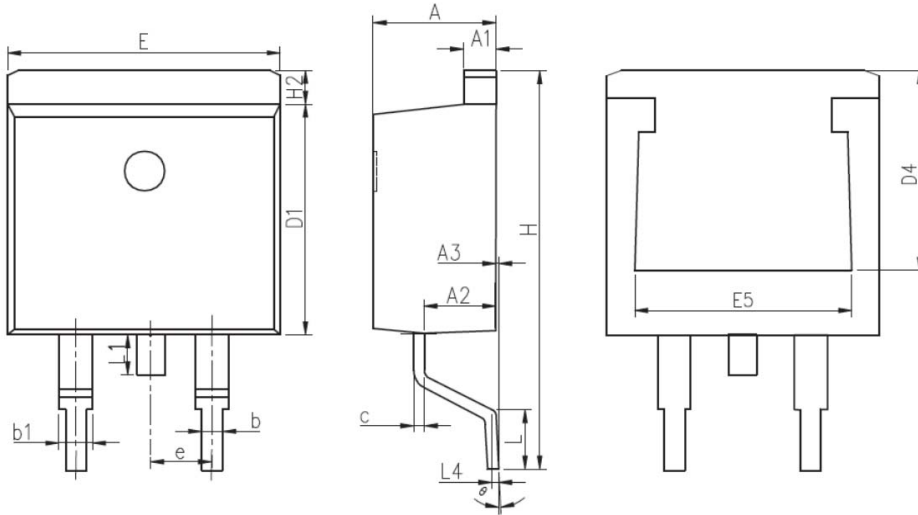

Fig11. Unclamped Inductive Test Circuit and waveforms

TO-263 Mechanical Data

DIMENSIONS (unit : mm)

Symbol	Min	Typ	Max	Symbol	Min	Typ	Max
A	4.37	4.57	4.77	A1	1.22	1.27	1.42
A2	2.49	2.69	2.89	A3	0	0.13	0.25
b	0.70	0.81	0.96	b1	1.17	1.27	1.47
c	0.3	0.38	0.53	D1	8.5	8.7	8.9
D4	6.6	--	--	E	9.86	10.16	10.36
E5	7.06	--	--	e	--	2.54	--
H	14.7	15.1	15.5	H2	1.07	1.27	1.47
L	2	2.3	2.6	L1	1.4	1.55	1.7
L4	--	0.25	--	θ	2.20	2.50	2.60

Legal Disclaimer

The Dowell Technology given in this document shall in no event be regarded as a guarantee of conditions or characteristics. With respect to any examples or hints given herein, any typical values stated herein and/or any information regarding the application of the device, Dowell Technology hereby disclaims any and all warranties and liabilities of any kind, including without limitation, warranties of non-infringement of intellectual property rights of any third party.

Information

For further information on technology, delivery terms and conditions and prices, please contact the nearest Dowell Technology Office (www.dowellsemi.com).

Warnings

Due to technical requirements, components may contain dangerous substances. For information on the types in question, please contact the nearest Dowell Technology Office. Dowell Technology components may be used in life-support devices or systems only with the express written approval of Dowell Technology, if a failure of such components can reasonably be expected to cause the failure of that life-support device or system or to affect the safety or effectiveness of that device or system. Life support devices or systems are intended to be implanted in the human body or to support and/or maintain and sustain and/or protect human life. If they fail, it is reasonable to assume that the health of the user or other persons may be endangered.