

Two Channel Differential 2:1/1:2 USB 3.1 Super Speed 10Gbps Mux/DeMux

Descriptions

The FSW3410 is a high speed bidirectional passive switch in mux or demux configurations suited for USB Type-C™ application supporting USB 3.1 Gen 1 and Gen 2 data rates. Based on control pin SEL, the device provides switching on differential channels between Port A or Port B to Port COM. The FSW3410 is a generic analog differential passive switch that can work for any high speed interface applications requiring a common mode voltage range of 0 to 2 V and differential signaling with differential amplitude up to 1800 mVpp. It employs adaptive tracking that ensures the channel remains unchanged for the entire common mode voltage range. Excellent dynamic characteristics of the device allow high speed switching with minimum attenuation to the signal eye diagram with very little added jitter. It consumes <2mW of power when operational and has a shutdown mode exercisable by EN pin resulting <20uW.

Features

- 2-Differential Channel 1:2/2:1 Mux/DeMux
- USB 3.1 Super Speed 10Gbps Switch
- High Bandwidth: 5.1GHz @-3dB BW
- Supports both AC coupled and DC coupled signals
- Isolation: -40dB @ 2.0 Gbps
- Crosstalk: -31dB @ 2.0 Gbps
- ESD Tolerance: 2kV HBM
- Low bit-to-bit skew, Bidirectional
- Wide VCC Operating Range: 1.5V ~ 5.0V

Applications

- USB Type-C Ecosystem
- Desktop and Notebook PCs
- Server/Storage Area Networks
- PCI Express Backplanes
- Shared I/O Ports
- FPD LinkII and FPD LinkIII Switching

Order information

Mode	Package	Ordering Number	Packing Option
FSW3410	QFN2.8x2.0-18L	FSW3410YQFN18G/TR	Tape and Reel,5000

Block Diagram

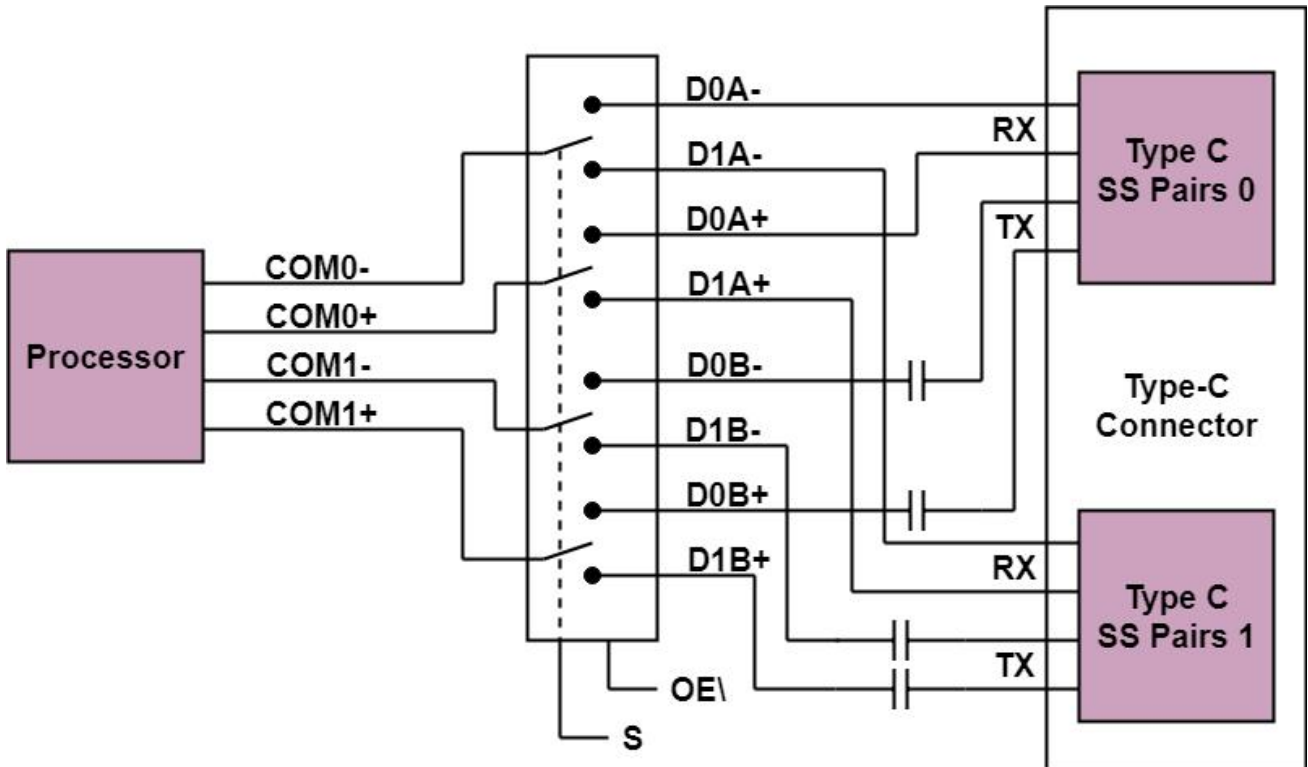

Typical Application

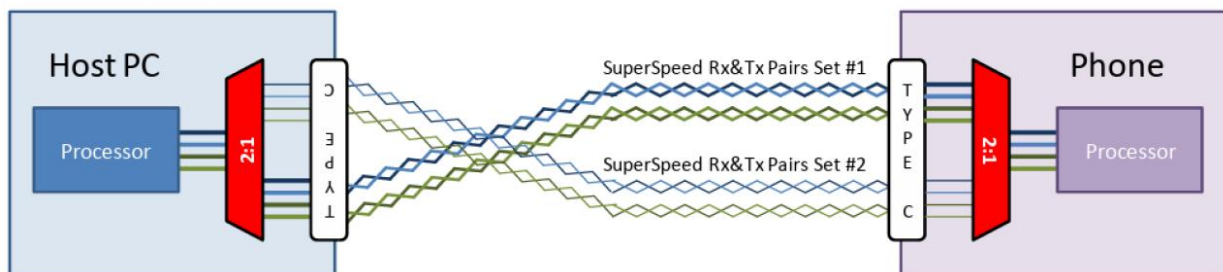

Pin Configuration

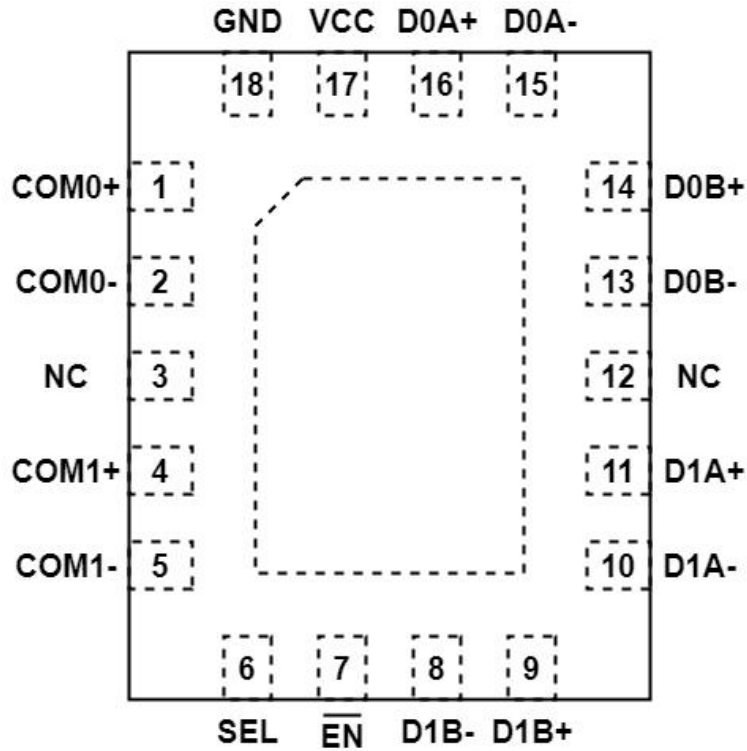

Pin#	Pin Name	Signal Type	Description
1	COM0+	I/O	Positive differential signal 0 for COM port
2	COM0-	I/O	Negative differential signal 0 for COM port
3	NC	/	Not Connected
4	COM1+	I/O	Positive differential signal 1 for COM port
5	COM1-	I/O	Negative differential signal 1 for COM port
6	SEL	I	Select Pin, See Truth Table
7	$\overline{\text{EN}}$	I	Enable Pin,Active Low
8	D1B-	I/O	Negative differential signal 1 for port B
9	D1B+	I/O	Positive differential signal 1 for port B
10	D1A-	I/O	Negative differential signal 1 for port A
11	D1A+	I/O	Positive differential signal 1 for port A
12	NC	/	Not Connected
13	D0B-	I/O	Negative differential signal 0 for port B
14	D0B+	I/O	Positive differential signal 0 for port B
15	D0A-	I/O	Negative differential signal 0 for port A
16	D0A+	I/O	Positive differential signal 0 for port A
17	VCC	Power	Positive Supply Voltage
18	GND	Ground	Power Ground

Truth Table

$\overline{\text{EN}}$	SEL	COM0-	COM0+	COM1-	COM1+
High	X	Hi-Z	Hi-Z	Hi-Z	Hi-Z
Low	Low	D0A-	D0A+	D0B-	D0B+
Low	High	D1A-	D1A+	D1B-	D1B+

Maximum Ratings

(Above which useful life may be impaired. For user guidelines, not tested.)

Storage Temperature	-65°C to +150°C
Junction Temperature	125°C
Supply Voltage to Ground Potential	-0.5V to +5.5V
Supere Speed Data Channel TX / RX	-0.5V to 3.8V
DC Input Voltage	-0.5V to VCC
DC Output Current	50mA
Power Dissipation	300mW

Notes:

Stresses greater than those listed under MAXIMUM RATINGS may cause permanent damage to the device. This is a stress rating only and functional operation of the device at these or any other conditions above those indicated in the operational sections of this specification is not implied. Exposure to absolute maximum rating conditions for extended periods may affect reliability.

Electrical Characteristics

(TA=25°C, VCC=1.8V, unless otherwise specified)

Parameter	Symbol	conditions	Min.	Typ.	Max	Unit
POWER SUPPLY						
VCC Quiescent Current	I _Q	SEL=0 or VCC, $\overline{\text{EN}}$ =0		28		uA
Power-down Current	I _{PO}	SEL=0 or VCC, $\overline{\text{EN}}$ =VCC			1	uA
DC CHARACTERISTICS						
Input logic high	V _{IH}	VCC=1.8~4.5V	1.6			V
Input logic low	V _{IL}	VCC=1.8~4.5V			0.4	V
$\overline{\text{EN}}$ Internal pull-up resistor	R _{UP}			2		MΩ
SEL Internal pull-down resistor	R _{DN}			2		MΩ
On-Resistance for TX/RX	R _{ON_HS}	V _{IS} = 0.2V I _{ON} =8mA		6.7	8	Ω
R _{ON} Flatness for TX/RX	R _{FLAT_LP}	V _{IS} = 0 to 1.2V I _{ON} =8mA		0.8	1	Ω
R _{ON} Flatness for TX/RX	R _{FLAT_LP}	V _{IS} = 0 to 0.2V I _{ON} =8mA		0.2	0.3	Ω
R _{ON} Matching Between Channels	R _{MATCH}	V _{IS} = 0 to 1.2V I _{ON} =8mA		0.1		Ω
Switch Off Leakage Current	I _{OFF}	$\overline{\text{EN}}$ =VCC, COM0, COM1=VCC D0A, D1A, D0B, D1B=0	-0.5		0.5	uA
AC CHARACTERISTICS						
Enable Time $\overline{\text{EN}}$ to Output	t _{EN}	R _L =50Ω C _L =0pF V _{IS} = 0.6V		80	150	uS
Disable Time $\overline{\text{EN}}$ to Output	t _{DIS}	R _L =50Ω C _L =0pF V _{IS} = 0.6V		40	250	nS
Turn-On Time SEL to Output	t _{ON}	R _L =50Ω C _L =0pF V _{IS} = 0.6V		400	1200	nS
Turn-Off Time SEL to Output	t _{OFF}	R _L =50Ω C _L =0pF V _{IS} = 0.6V		130	800	nS
Break-Before-Make Time	t _{BBM}	R _L =50Ω C _L =0pF V _{IS} = 0.6V		250	800	nS
Propagation Delay	t _{PD}	R _L =50Ω C _L =0pF V _{IS} = 0.6V		0.25		nS

Off Isolation	Off	$R_L = 50\Omega$ $f = 1.2\text{GHz}$ $V_{IS} = 0.2V_{PP}$, See Fig.2		-27		dB
Crosstalk	X_{TALK}	$R_L = 50\Omega$ $f = 1.2\text{GHz}$ $V_{IS} = 0.2V_{PP}$, See Fig.1		-43		dB
-3dB Bandwidth	BW_{-3dB}	$R_L = 50\Omega$ $C_L = 0\text{pF}$ Signal 0dBm	4.5	5.1		GHz
CAPACITANCE						
Switch On Capacitance	C_{ON}	$V_{Bias} = 0.2V$, $f = 1.5\text{GHz}$		1.5		pF
Switch Off Capacitance	C_{OFF}	$V_{Bias} = 0.2V$, $f = 1.5\text{GHz}$		1.0		pF

Notes:

- (1) Flatness is defined as the difference between maximum and minimum value of ON-resistance at the specified analog signal voltage points.
- (2) R_{ON} matching between channels is calculated by subtracting the channel with the lowest max Ron value from the channel with the highest max Ron value.
- (3) Crosstalk is inversely proportional to source impedance

Application Information

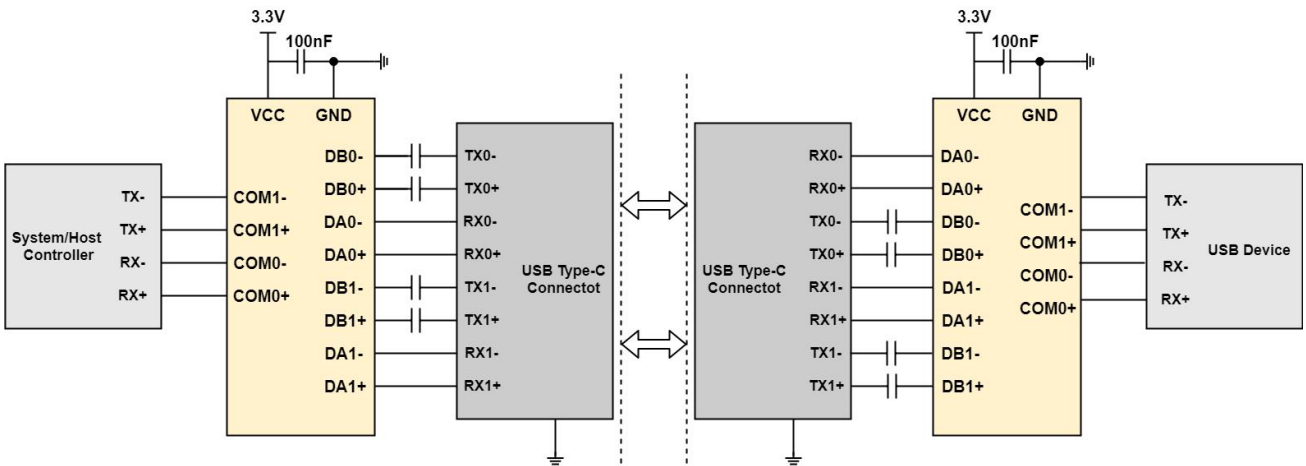
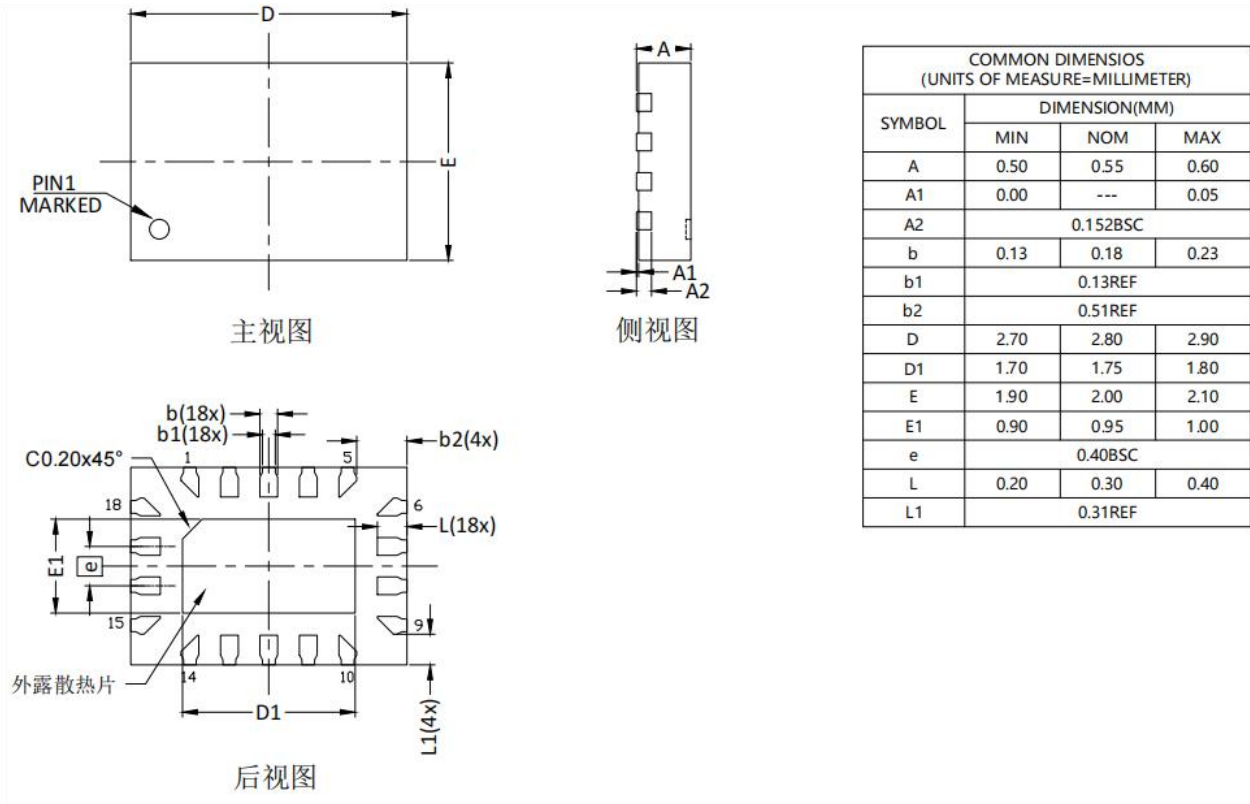

Fig. AC Coupling Capacitors for USB Type-C

Package Outline Dimensions(All dimensions in mm.)

(1) Package Type: QFN2.8x2.0-18L



Version Modification Record

Version Number	Revision	Date
first edition		/
V1.0	1. Update the order information on page 2	2024/07/5