Ultra-Low-Power Omnipolar Switch Hall Effect Sensor

FEATURES

- Industry ultra-low power consumption
 - 1.2 μ A with 3.0 V
- 1.65V to 5.5V operating range
- Push-Pull and Open-Drain output options
- SOT-23 and TO-92 package options
- 0°C to +85°C operating temperature range

APPLICATIONS

- Battery-critical position sensing
- Electricity meter tamper detection
- Cell Phone, laptop, or tablet case sensing
- E-locks, smoke detectors, appliances
- Medical devices, IoT systems
- Valve or solenoid position detection
- Contactless diagnostics or activation

DESCRIPTION

The SC206X family is an ultra-low-power Omni-polar switch Hall Effect Sensor, designed for the most compact and battery-sensitive systems. The device is offered in multiple magnetic thresholds, sampling rates, output drivers, and packages to accommodate various applications.

When the applied magnetic flux density exceeds the BOP threshold, the device outputs a low voltage. The output stays low until the flux density decreases to less than BRP, and then the output either drives a high voltage or becomes high impedance, depending on the device version. By incorporating an internal oscillator, the device samples the magnetic field and updates the output at a rate of 20 Hz for the lowest current consumption. Omnipolar magnetic responses are available.

The device operates from a V_{DD} range of 1.65 V to 5.5 V, and is packaged in a standard SOT-23, TO-92.



ORDERING INFORMATION

Part Number	Packing Form	MAGNETIC RESPONSE	Package	Output Type	BOP (Typ.)	BRP (Typ.)
SC2062UA	BU	Omnipolar	SIP3	Push-Pull	Typ. ± 20 Gs	Typ. ± 10 Gs
SC2062SO	RE		SOT-23	Push-Pull		
SC2063UA	BU		SIP3	Push-Pull	Typ. ± 30 Gs	Typ. ± 20 Gs
SC2063SO	RE		SOT-23	Push-Pull		
SC2064UA	BU		SIP3	Open-Drain	Typ. ± 30 Gs	Typ. ± 20 Gs
SC2064SO	RE		SOT-23	Open-Drain		

CONTENTS

FEATURES	- 1 -	<i>Magnetic Characteristics</i>	- 8 -
APPLICATIONS	- 1 -	TYPICAL CHARACTERISTIC	- 8 -
DESCRIPTION	- 1 -	FUNCTION DESCRIPTION	- 10 -
ORDERING INFORMATION	- 2 -	<i>Field Direction Definition</i>	- 10 -
BLOCK DIAGRAM	- 4 -	<i>Transfer Function</i>	- 11 -
TERMINAL CONFIGURATION	- 5 -	TYPICAL APPLICATION	- 12 -
ABSOLUTE MAXIMUM RATINGS	- 6 -	PACKAGE INFORMATION “UA”	- 14 -
ESD PROTECTION	- 6 -	PACKAGE INFORMATION “SO”	- 15 -
THERMAL CHARACTERISTICS	- 6 -	REVISION HISTORY	- 16 -
OPERATING CHARACTERISTICS	- 7 -		
<i>Electrical Characteristics</i>	- 7 -		

BLOCK DIAGRAM

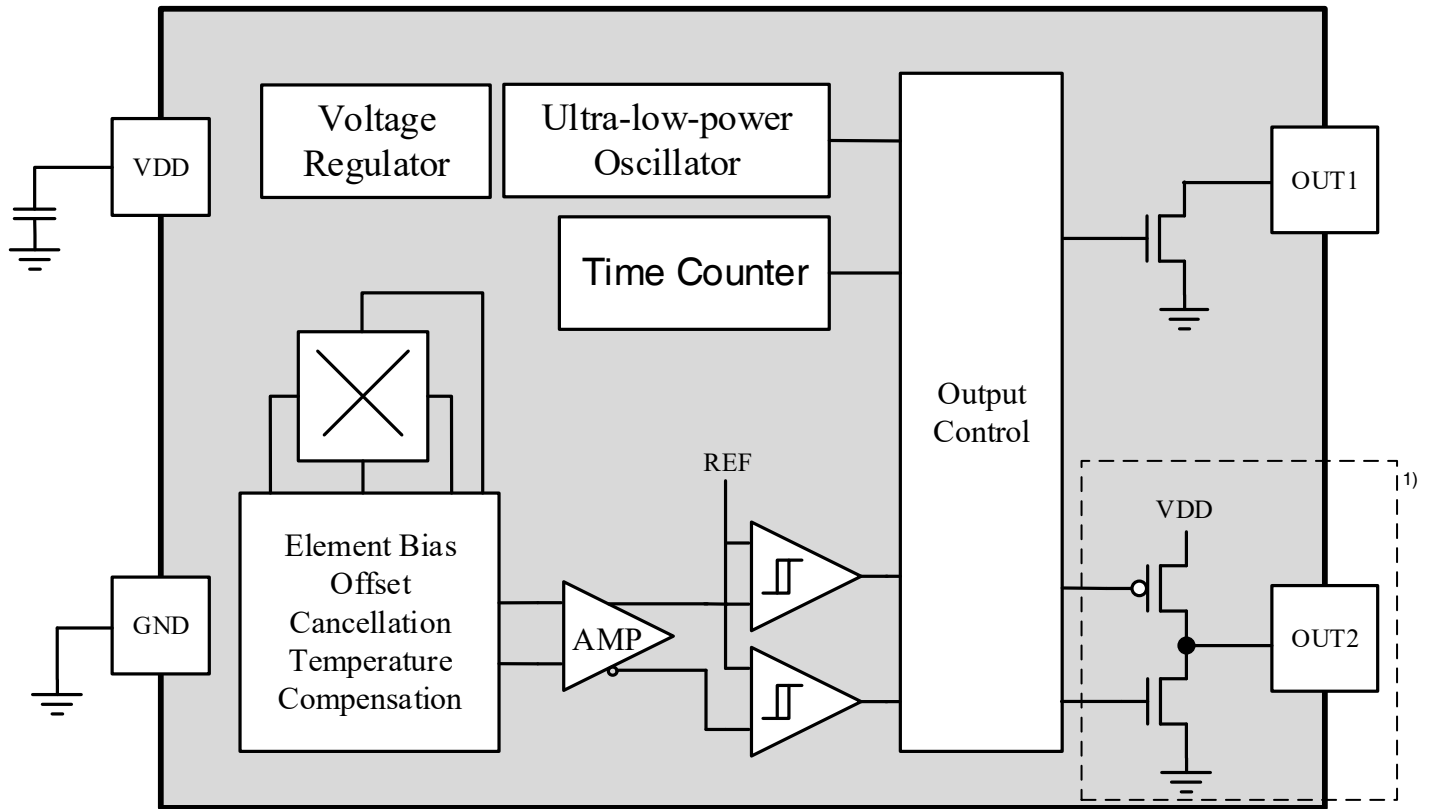

1) Output type depends on device version

TERMINAL CONFIGURATION

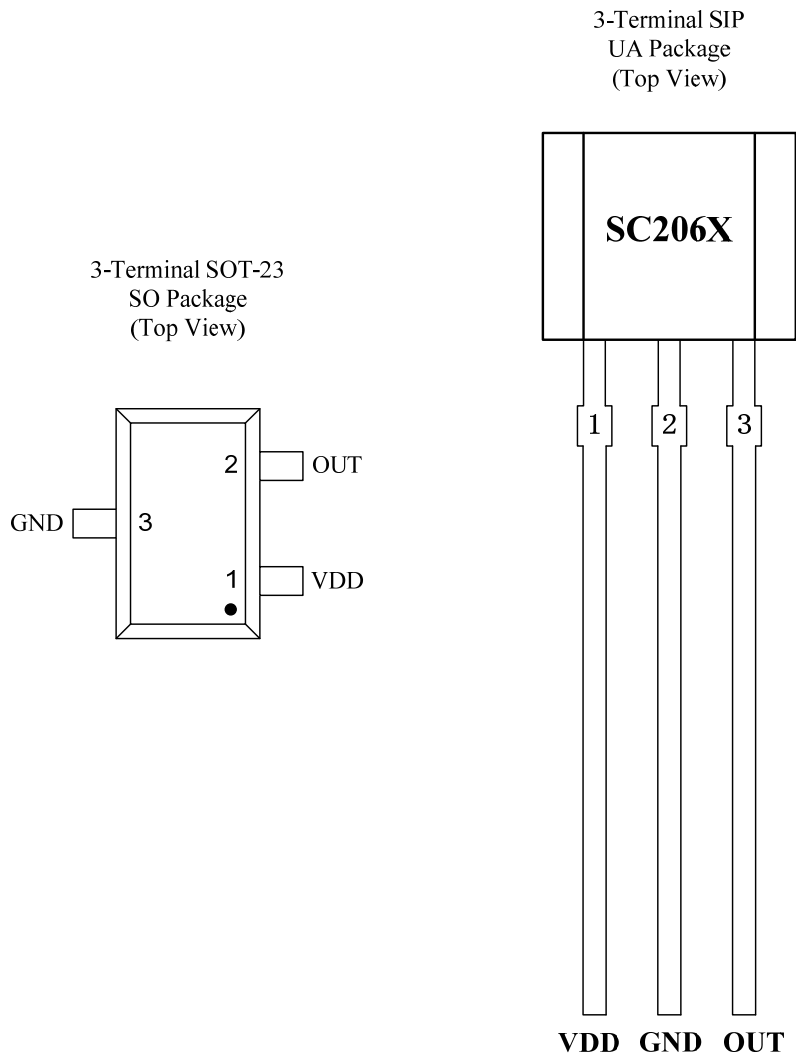

Terminal		Type	Description
Name	Number		
	UA	SO	
VDD	1	1	PWR 1.65V to 5.5V power supply
GND	2	3	Ground Ground terminal
OUT	3	2	Output Push-Pull or Open-drain output. The open drain requires a pull-up resistor to supply.

ABSOLUTE MAXIMUM RATINGS

over operating free-air temperature range (unless otherwise noted) ⁽¹⁾

Parameter	Symbol	Min.	Max.	Units
Power supply voltage	V _{DD}	-0.3	6	V
Output terminal voltage	V _{OUT}	-0.3	6	V
Output terminal current sink	I _{SINK}	0	5	mA
Operating ambient temperature	T _A	-40	85	°C
Maximum junction temperature	T _J	-55	125	°C
Storage temperature	T _{STG}	-65	125	°C

(1) Stresses above those listed here may cause permanent damage to the device. Exposure to absolute maximum rating conditions for extended periods may affect device reliability.

ESD PROTECTION

Human Body Model (HBM) tests according to: standard ANSI/ESDA/JEDEC JS-001

Parameter	Symbol	Min.	Max.	Units
ESD-Protection	V _{ESD}	-6	+6	KV

THERMAL CHARACTERISTICS

Symbol	Parameter	Test Conditions	Rating	Units
R _{θja}	UA Package thermal resistance	Single-layer PCB, with copper limited to solder pads	166	°C/W
R _{θja}	SO Package thermal resistance	Single-layer PCB, with copper limited to solder pads	228	°C/W

OPERATING CHARACTERISTICS

Electrical Characteristics

over operating free-air temperature range ($V_{DD} = 1.8V$, unless otherwise noted)

Symbol	Parameter	Test Conditions	Min.	Typ.	Max.	Units
Operating Characteristics						
V_{DD}	Operating voltage ⁽¹⁾	$T_J < T_{J(Max.)}$	1.65	--	5.5	V
$t_{V_{DD}slope}$	$t_{V_{DD}slope} = 0 \rightarrow 0.9 \cdot V_{DD}$	$V_{DD} = 1.65V$ to $5.5V$	--	--	100	μS
$I_{DD (Average)}$	Average current consumption	$V_{DD} = 1.8V$	--	1.0	1.7	μA
		$V_{DD} = 3V$	--	1.2	1.9	μA
		$V_{DD} = 5V$	--	1.6	2.6	μA
$I_{DD (peak)}$	Peak current consumption	$V_{DD} = 1.65V$ to $5.5V$	1.1	1.4	1.8	mA
t_{ACTIVE}	Active time	$V_{DD} = 1.65V$ to $5.5V$	25	40	55	μS
t_{ON}	Power on time	$V_{DD} = 1.65V$ to $5.5V$	--	40	55	μS
f_S	Frequency of magnetic sampling	$V_{DD} = 1.65V$ to $5.5V$	10	20	30	Hz
t_S	Period of magnetic sampling	$V_{DD} = 1.65V$ to $5.5V$	33	50	100	mS
Push Pull Output Characteristics						
V_{OH}	High-level output voltage	$I_{OUT} = -1$ mA	$V_{DD} - 0.35V$	$V_{DD} - 0.1V$	--	V
V_{OL}	Low-level output voltage	$I_{OUT} = 1$ mA	--	0.1	0.3	V
Open Drain Output Characteristics						
I_{LINK}	Output leakage current	$V_{DD} = 5.5$ V, $OUT = 5.5$ V	--	--	100	nA
V_{OL}	Low-level output voltage	$I_{OUT} = 1$ mA	--	0.1	0.3	V

Magnetic Characteristics

over operating free-air temperature range (unless otherwise noted)

Symbol	Parameter	Test Conditions	Min.	Typ.	Max.	Units
B _{OP}	Operated point	T _A =25°C (SC2062)	±0.5	±2.0	±3.5	mT
B _{RP}	Release point		±0.1	±1.0	±2.0	mT
B _{HYS}	Hysteresis		±0.1	±1.0	±1.5	mT
B _{OP}	Operated point	T _A =25°C (SC2063/SC2064)	±1.5	±3.0	±4.5	mT
B _{RP}	Release point		±1.0	±2.0	±3.0	mT
B _{HYS}	Hysteresis		±0.1	±1.0	±1.5	mT

1mT=10GS, Magnetic flux density, B, is indicated as a negative value for North-polarity magnetic fields, and as a positive value for South-polarity magnetic fields.

TYPICAL CHARACTERISTIC

SC2062/3/4

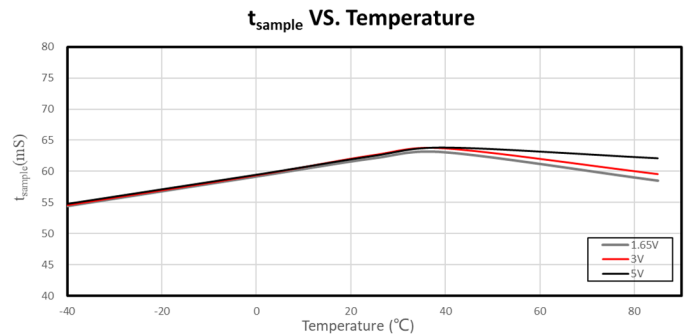
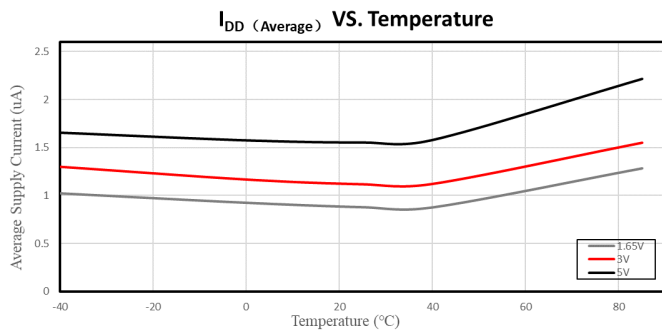

SC2063/4

$|B_{OP}|$ VS. Temperature

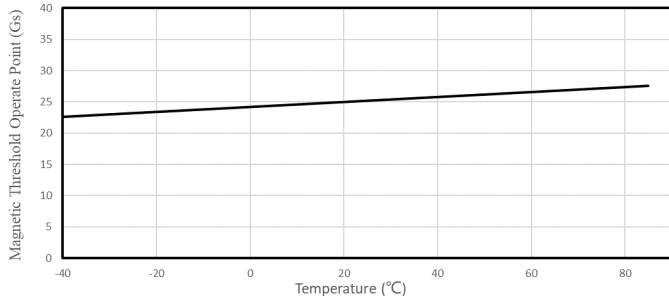

$|B_{RP}|$ VS. Temperature

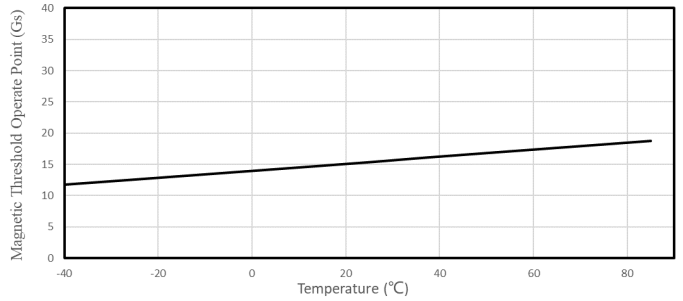

$|B_H|$ VS. Temperature

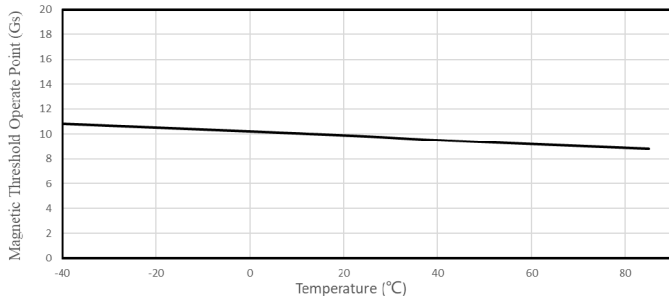

$|B_{OP}|$ VS. Supply Voltage

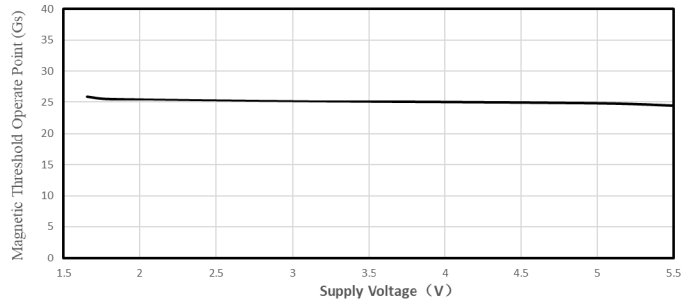

$|B_{RP}|$ VS. Supply Voltage

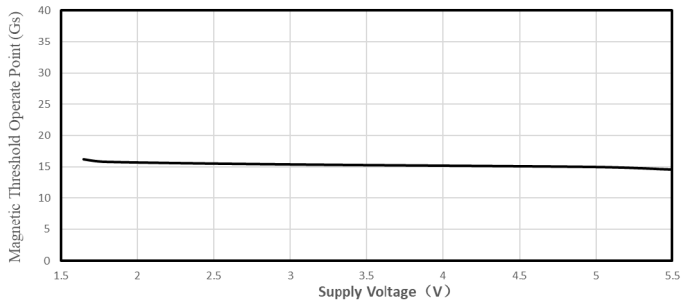

$|B_H|$ VS. Supply Voltage

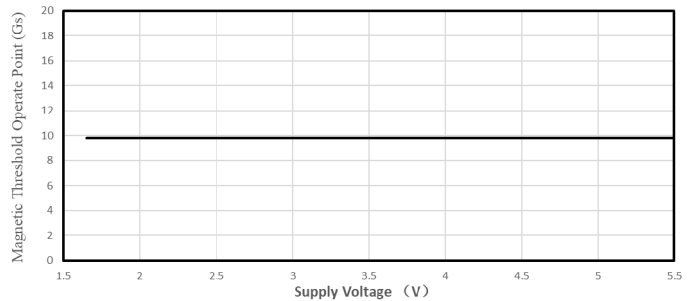

FUNCTION DESCRIPTION

The SC206X device is a magnetic sensor with a digital output that indicates when the magnetic flux density threshold has been crossed. The device integrates a Hall Effect element, analog signal conditioning, and a low-frequency oscillator that enables ultra-low average power consumption. By operating from a 1.65V to 5.5V supply, the device periodically measures magnetic flux density, updates the output, and enters a low-power sleep state.

The output of SC206X switches low (turns on) when a magnetic field (South or North polarity) perpendicular to the Hall element exceeds the operate point threshold, B_{OP} . After turn-on, the output is capable of sinking 5mA and the output voltage is V_Q (sat). When the magnetic field is reduced below the release point, B_{RP} , the device output goes high (turns off). The difference in the magnetic operate and release points is the hysteresis, B_{HYS} , of the device. This built-in hysteresis allows clean switching of the output even in the presence of external mechanical vibration and electrical noise.

Field Direction Definition

A positive magnetic field is defined as a South Pole near the marked side of the package.

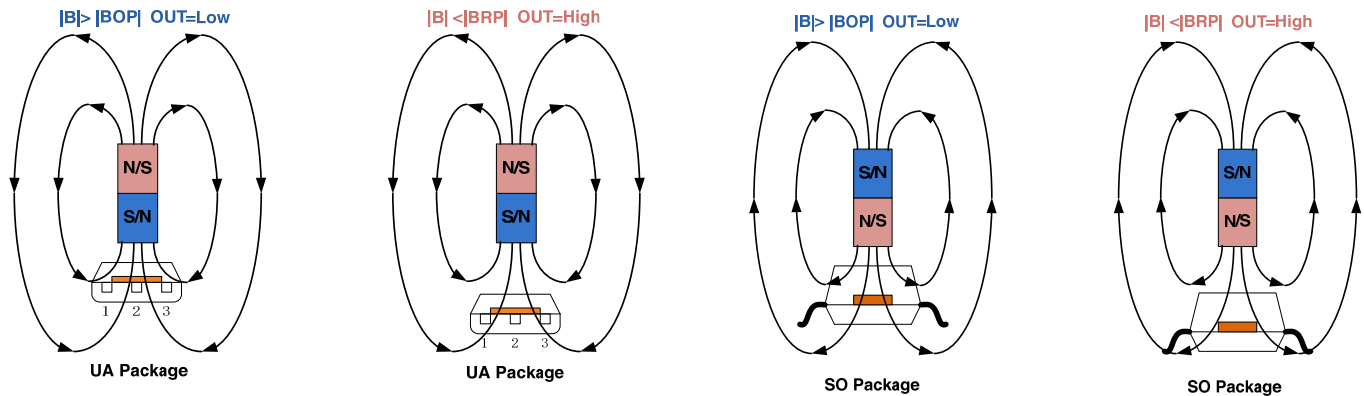

Transfer Function

The SC206X exhibits “Omni polar” magnetic characteristics. It means the device reacts to both North and South magnetic pole. The purpose is to detect the presence of any magnetic field applied on the device. This mode of operation simplifies customer production processes by avoiding the need to detect the Hall sensor pole active on the magnet used in the application. Therefore, the “Omni polar” magnetic behavior helps customers by removing the need of magnet pole detection system during production phase.

Powering-on the device in the hysteresis region, less than B_{OP} and higher than B_{RP} , allows an indeterminate output state. The correct state is attained after the first excursion beyond B_{OP} or B_{RP} . If the field strength is greater than B_{OP} , then the output is pulled low. If the field strength is less than B_{RP} , the output is released.

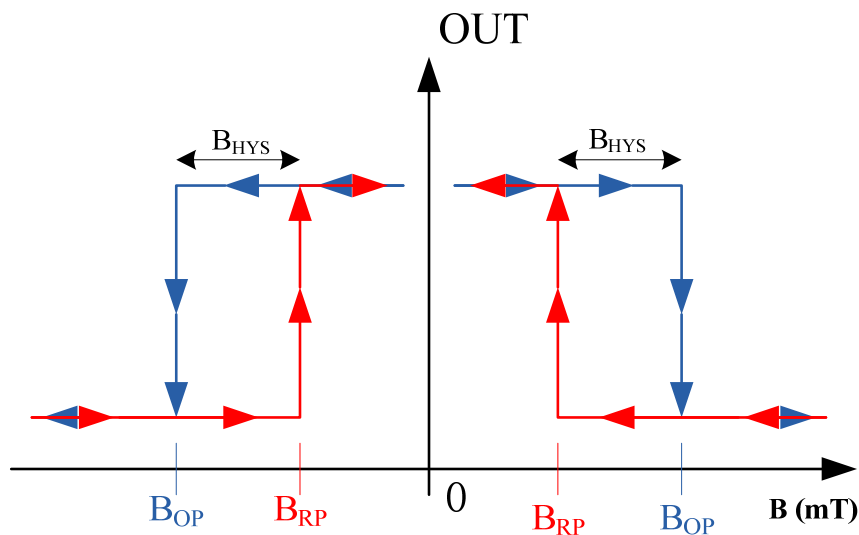

TYPICAL APPLICATION

Push Pull Output

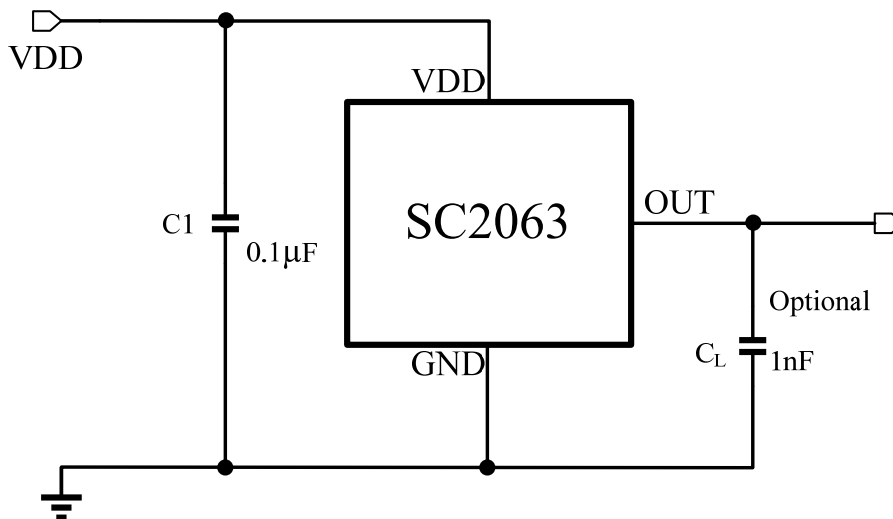
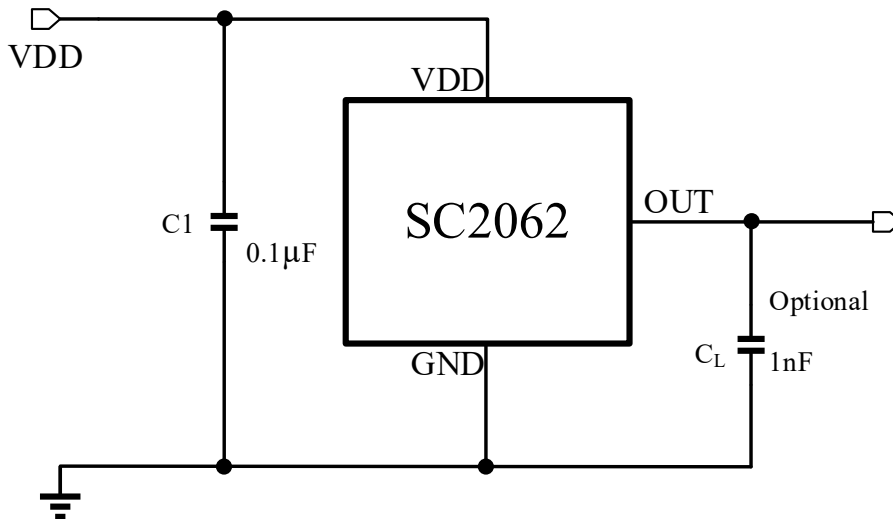

Open Drain Output

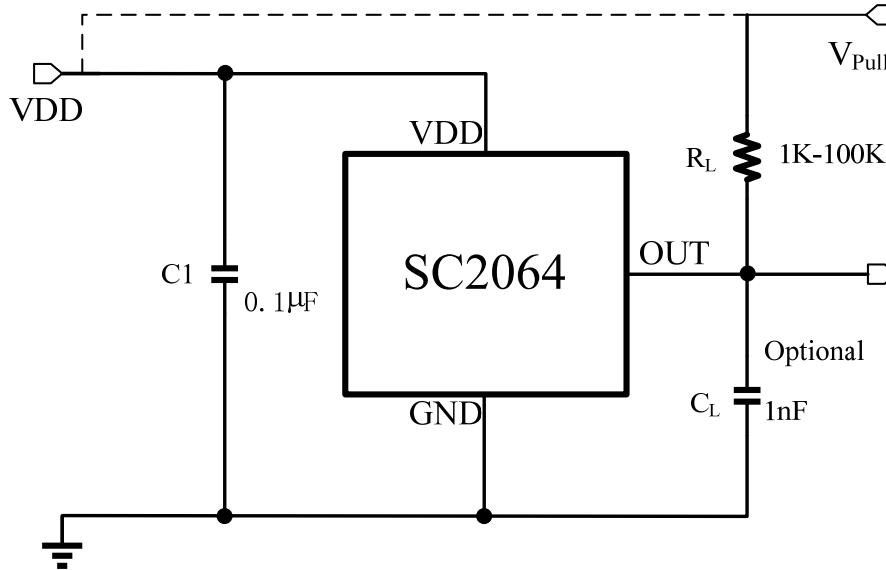

PACKAGE INFORMATION “UA”

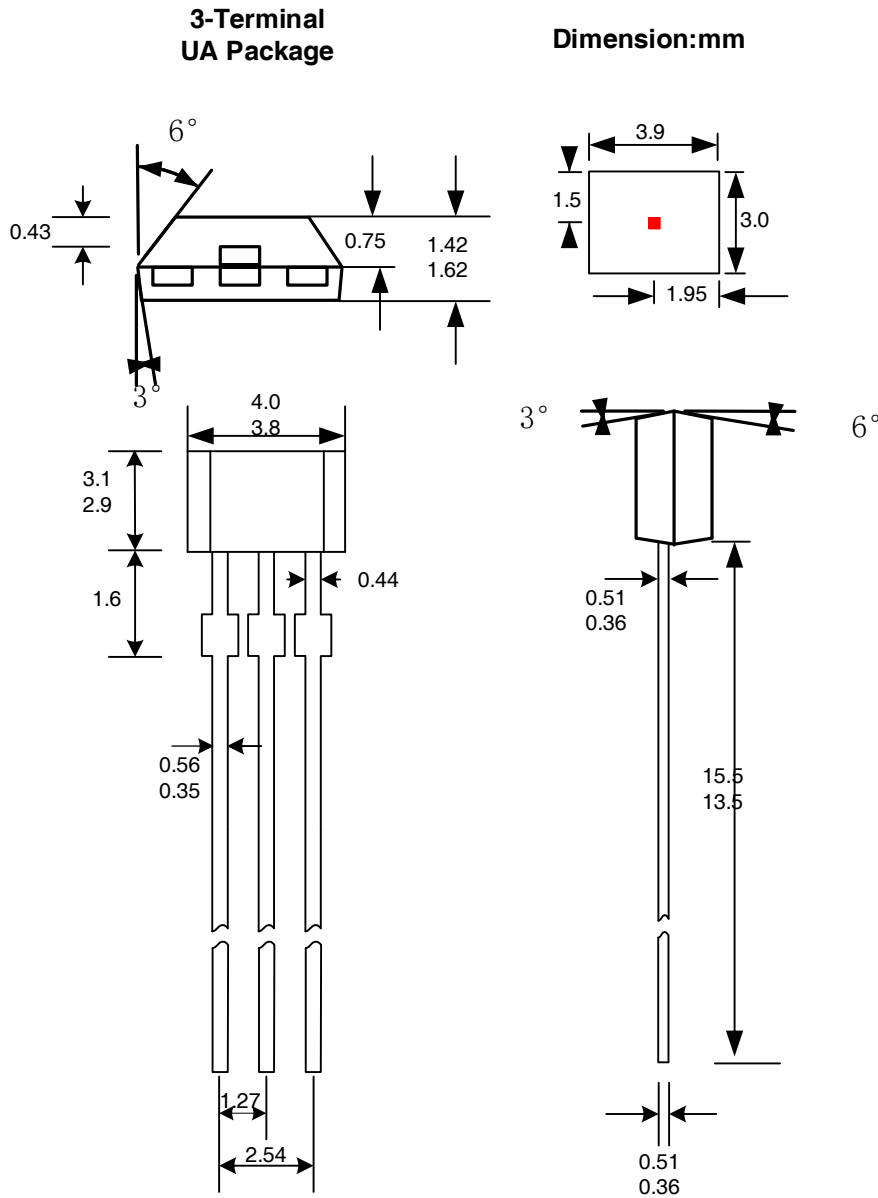

Notes:

1. Exact body and lead configuration at vendor's option within limits shown.
2. Height does not include mold gate flash.

Where no tolerance is specified, dimension is nominal.

PACKAGE INFORMATION “SO”

**3-Terminal
SO Package**

Dimension:mm

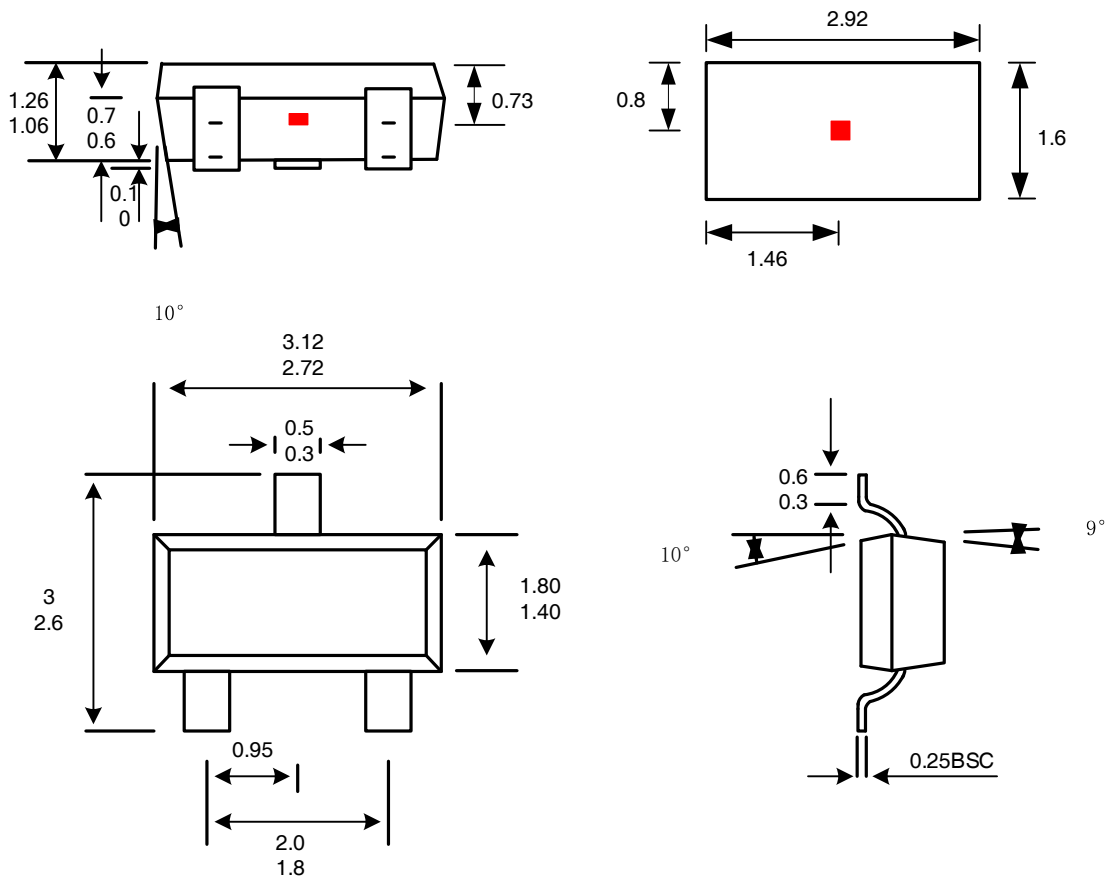

Notes:

1. Exact body and lead configuration at vendor's option within limits shown.
2. Height does not include mold gate flash.

Where no tolerance is specified, dimension is nominal.

REVISION HISTORY

Revision	Date	Description
Rev0.1	2022-03-18	Preliminary Datasheet
Rev1.0	2022-05-28	Release datasheet
Rev1.1	2024-05-11	Add SC2062 Part Number