

## 2.50mm Pitch Wire To Board Connector

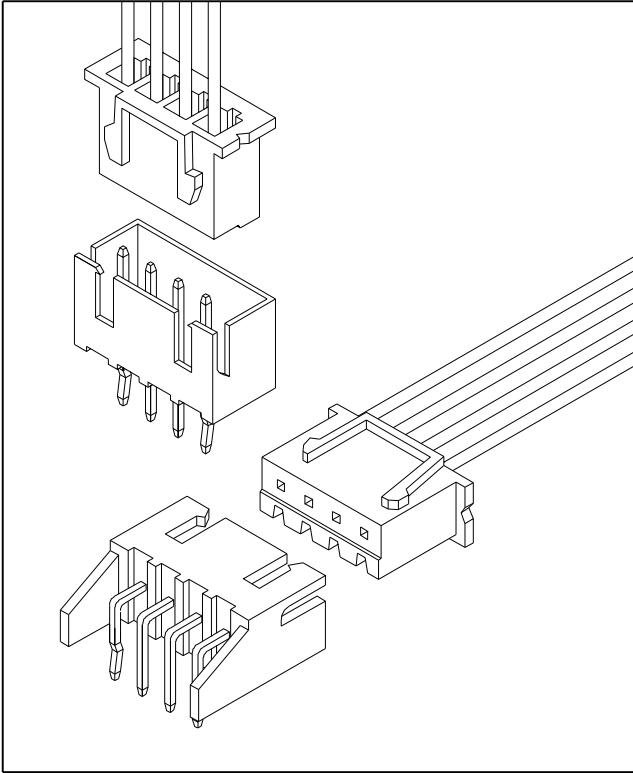

### Specification

<b>Circuits</b>	02-16 , 20
<b>Pitch</b>	2.50mm
<b>Current Rating</b>	3A AC/DC
<b>Voltage Rating</b>	250V AC/DC
<b>Contact Resistance</b>	10mΩ MAX.
<b>Withstand Voltage</b>	8,00V AC/minute
<b>Insulation Resistance</b>	1,000MΩ MIN.
<b>Temperature Range</b>	-25°C - +85°C
<b>Applicable Wire Range</b>	AWG #22 - #28
<b>Applicable P.C.B Thickness</b>	1.6mm
<b>Applicable P.C.B Hole Dia.</b>	Ø 1.0mm ± 0.05

### Assembly Layout

Vertical Type

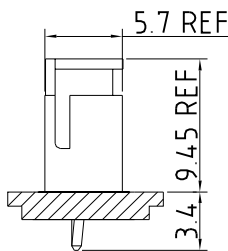

Right Angle Type

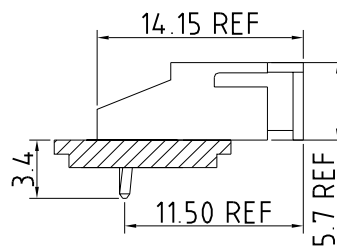

IPCW250 \* \*\* \* \* \* \* \*  
 ① ② ③ ④ ⑤ ⑥ ⑦ ⑧

- ① Series Type. IPCW250
- ② Connector Type.  
T: Terminal  
W: Wafer  
H: Housing
- ③ Pin code.  
Row  
Pin number of row

- ④ Material code.
- ⑤ Appearance code.
- ⑥ Internal code
- ⑦ Company code.

- ⑧ Other code.  
Wafer  
V: Vertical Type  
R: Right Angle  
S: Vertical SMT TYPE (02 - 08)  
T: Vertical SMT TYPE (09 - 16)  
M: Right Angle SMT TYPE

**Unit : mm**

### Terminal

#### Features

Use with: IPCW250 Series Housing

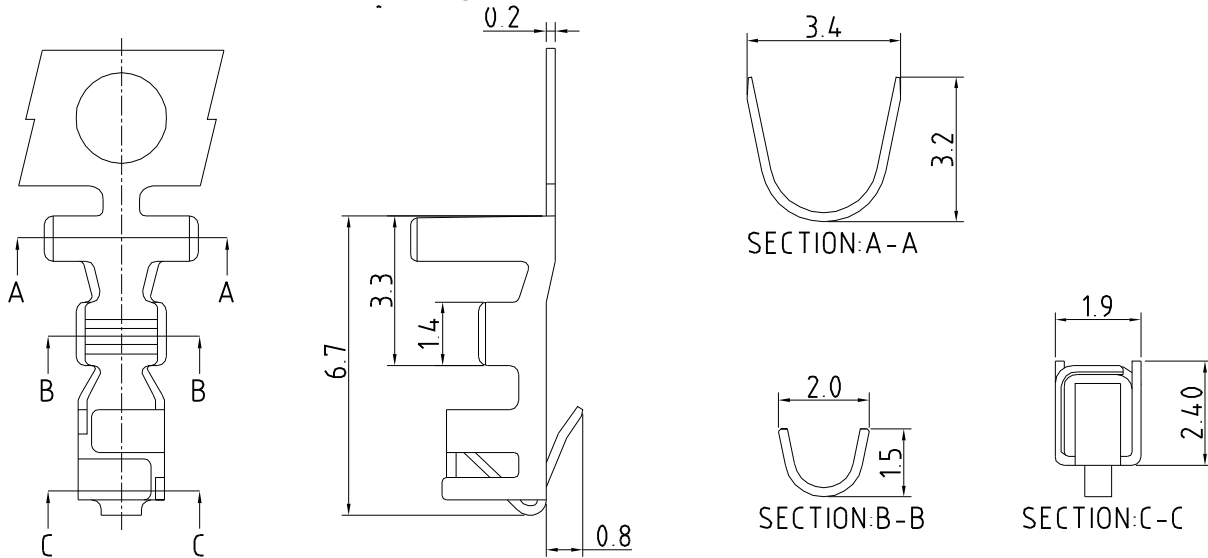

#### CONTACT INFORMATION

Part No.	Wire Range	Insulation O.D.	Material	Finish	Q'ty/Reel
IPCW250T01*	AWG #22-#28	1.90mm(MAX.)	Brass	See note	8,000 pcs
IPCW250T02*			Phosphor bronze		

Note:

For this product in a different specification please contact INCP for more information

### Housing

#### Features

Available Number of Circuits: 02-16, 20

Material: Regular Thermoplastic 94V-0

Use with: IPCW250 Crimp Terminal

Mates with : IPCW250 Series Wafer

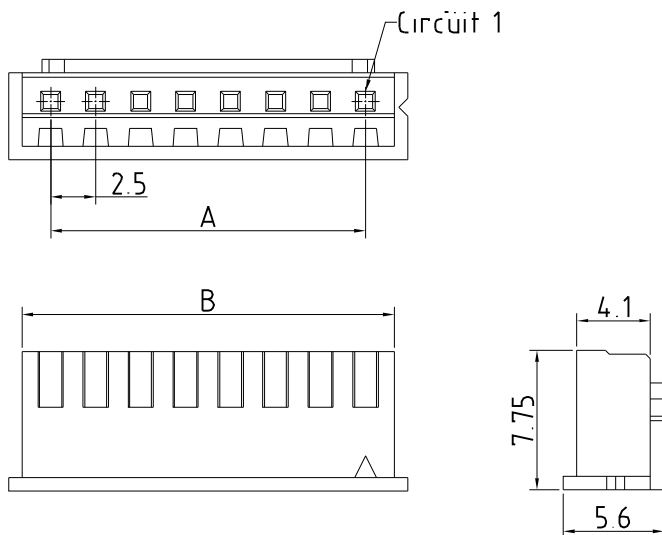

#### Dimension and Order Information

Circuits	Part No.	DIM.(mm)	
		A	B
2	IPCW250H12*	2.50	5.70
3	IPCW250H13*	5.00	8.20
4	IPCW250H14*	7.50	10.70
5	IPCW250H15*	10.00	13.20
6	IPCW250H16*	12.50	15.70
7	IPCW250H17*	15.00	18.20
8	IPCW250H18*	17.50	20.70
9	IPCW250H19*	20.00	23.20
10	IPCW250H1A*	22.50	25.70
11	IPCW250H1B*	25.00	28.20
12	IPCW250H1C*	27.50	30.70
13	IPCW250H1D*	30.00	33.20
14	IPCW250H1E*	32.50	35.70
15	IPCW250H1F*	35.00	38.20
16	IPCW250H1G*	37.50	40.70
20	IPCW250H1K*	47.50	50.70

## 2.50mm Pitch Wire To Board Connector

Unit : mm

### Wafer

Vertical

#### Features

Available Number of Circuits : 02-16 , 20

Material : Regular Thermoplastic 94V-0

Contact: 0.64mm(.025") Copper Alloy, Tin-plated

Mates with : IPCW250 Series Housing

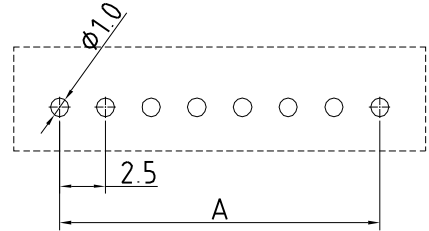
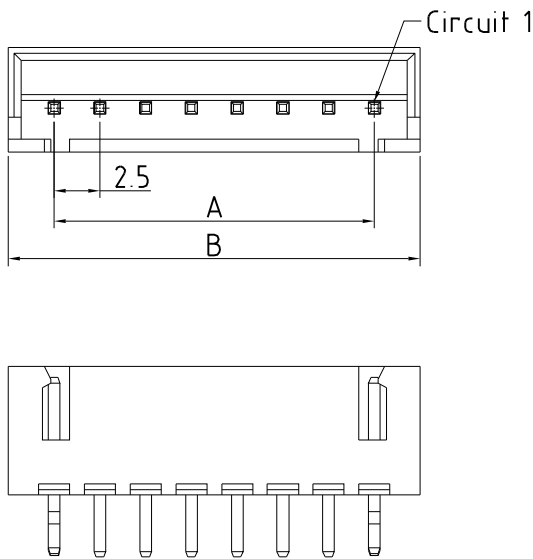

P.C.B LAYOUT

#### Dimension and Order Information

Circuits	Part No.	DIM.(mm)	
		A	B
2	IPCW250W12*V	2.50	7.50
3	IPCW250W13*V	5.00	10.00
4	IPCW250W14*V	7.50	12.50
5	IPCW250W15*V	10.00	15.00
6	IPCW250W16*V	12.50	17.50
7	IPCW250W17*V	15.00	20.00
8	IPCW250W18*V	17.50	22.50
9	IPCW250W19*V	20.00	25.00
10	IPCW250W1A*V	22.50	27.50
11	IPCW250W1B*V	25.00	30.00
12	IPCW250W1C*V	27.50	32.50
13	IPCW250W1D*V	30.00	35.00
14	IPCW250W1E*V	32.50	37.50
15	IPCW250W1F*V	35.00	40.00
16	IPCW250W1G*V	37.50	42.50
20	IPCW250W1K*V	47.50	52.50

### Wafer

Right Angle

#### Features

Available Number of Circuits : 02-16 , 20

Material : Regular Thermoplastic 94V-0

Contact: 0.64mm(.025") Copper Alloy, Tin-plated

Mates with : IPCW250 Series Housing

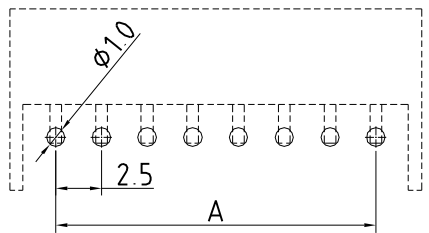
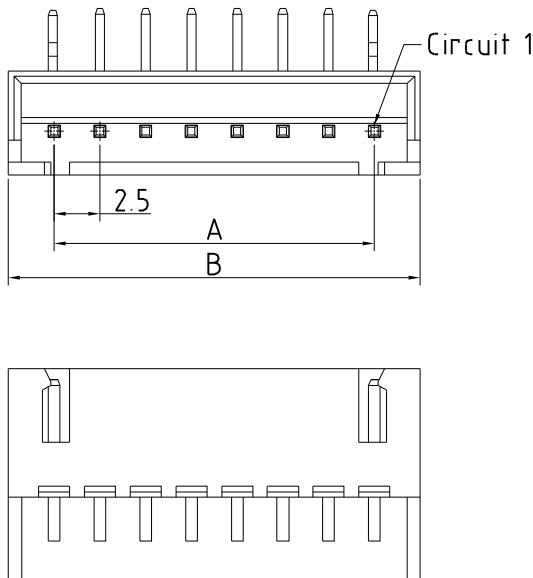

P.C.B LAYOUT

#### Dimension and Order Information

Circuits	Part No.	DIM.(mm)	
		A	B
2	IPCW250W12*R	2.50	7.50
3	IPCW250W13*R	5.00	10.00
4	IPCW250W14*R	7.50	12.50
5	IPCW250W15*R	10.00	15.00
6	IPCW250W16*R	12.50	17.50
7	IPCW250W17*R	15.00	20.00
8	IPCW250W18*R	17.50	22.50
9	IPCW250W19*R	20.00	25.00
10	IPCW250W1A*R	22.50	27.50
11	IPCW250W1B*R	25.00	30.00
12	IPCW250W1C*R	27.50	32.50
13	IPCW250W1D*R	30.00	35.00
14	IPCW250W1E*R	32.50	37.50
15	IPCW250W1F*R	35.00	40.00
16	IPCW250W1G*R	37.50	42.50
20	IPCW250W1K*R	47.50	52.50