

深圳市维拓精电科技有限公司
WTL International Limited

APPROVAL SHEET

DESCRIPTION :	5.0*3.2mm 4 Pads SMD Quartz Crystal			
NOMINAL FREQ.:	26.000MHz			
WTL P/N:	WTL5M95453PH			
VERSION:	1			
DATE:	2024.3.01			
Customer	Customer P/N			
/	/			
Customer Signature	WTL			
	Approved by:	<i>Kevin Liu</i>		
	Checked by:	<i>Shu Ping</i>		
	Issued by:	<i>colin zhan</i>		
REVISION HISTORY				
Revised Page	Revision Content	Date	Ref. No.	Reviser

CONTENT CATALOG

APPROVAL SHEET	P. 1
CONTENT CATALOG	P. 2
ELECTRICAL SPECIFICATIONS	P. 3
DIMENSIONS	P. 4
MARKING	P. 4
STRUCTURE ILLUSTRATION	P. 5
RELIABILITY SPECIFICATIONS	P. 6
SUGGESTED REFLOW PROFILE	P. 7
SUBSTANCES IN PRODUCT	P. 7
PACKING SPECIFICATIONS	P. 8
WTL PART NUMBER SYSTEM	P. 9

Attachment(s):

- 1.Product Specification Sheet
- 2.Electrical Testing Report
- 3.Reliability Report
- 4.ICP Test Report

FEATURE

- Size 5.0×3.2 , thickness 0.9mm
- High precision and high frequency stability
- Excellent heat resistance and environmental characteristics
- Designed for automatic mounting and reflow soldering
- RoHS Compliant / Pb Free

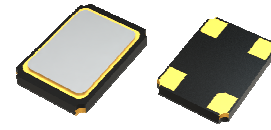

1、 ELECTRICAL SPECIFICATIONS

Hold Style	5032 Seam
Nominal Frequency	26.000MHz
Mode	Fundamental / AT
Frequency Tolerance (at 25°C)	±30ppm
Frequency Stability Over Operating Temperature Characteristics	±50ppm
Operating Temperature Range	-20°C ~ +70°C
Storage Temperature Range	-55°C ~ +125°C
Shunt Capacitance (C ₀)	5.0pF Max
Driver Level (Typical)	100μW
Load Capacitance(C _L)	13pF
ESR	50Ω Max
Insulation Resistance	More than 500Mohms at DC100V
Aging @25°C 1 st year (Max)	±3ppm/year

REMARK: SPECIFICATIONS SUBJECT TO CHANGE WITHOUT PRIOR NOTICE. PLEASE CONFIRM WITH OUR SALES ENGINEER.

2、 DIMENSIONS (Unit: mm)

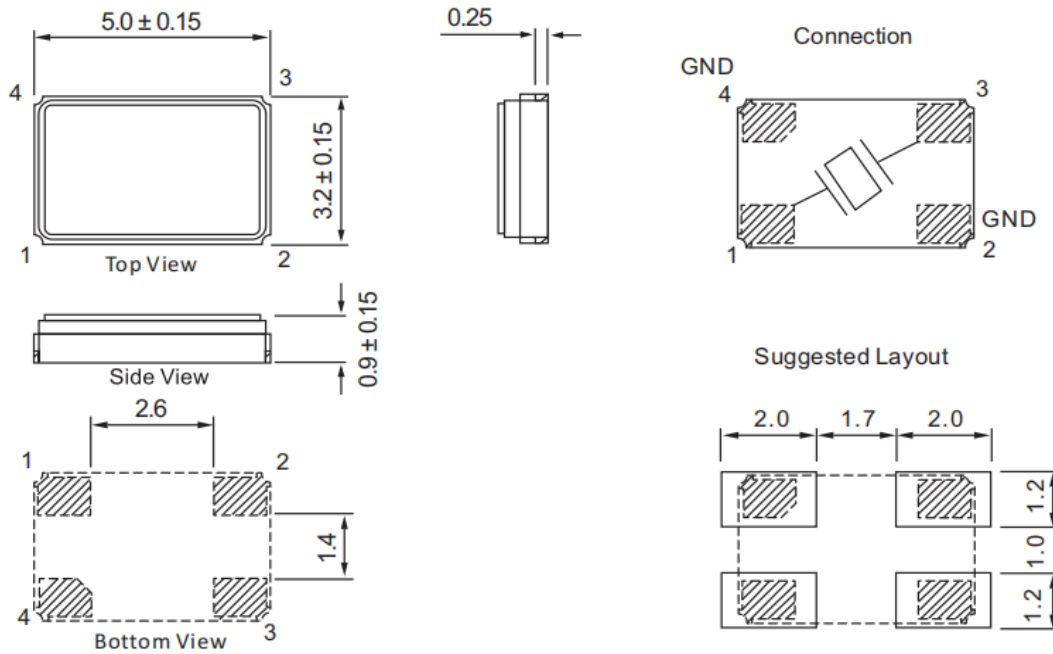

3、 MARKING

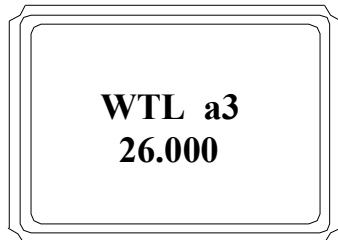

- WTL → Brand Logo
- 26.000 → Frequency (MHz)
- a → Week (a、b、c...z、A、B、C...Y、Z, from 1 to 52week)
- 3 → YEAR (1=2021year, 2=2022year, 9=2029year....)

Marking Instruction :

The date code was marked on the crystal body, which will be easily traced back in case of quality issue.

4、STRUCTURE ILLUSTRATION

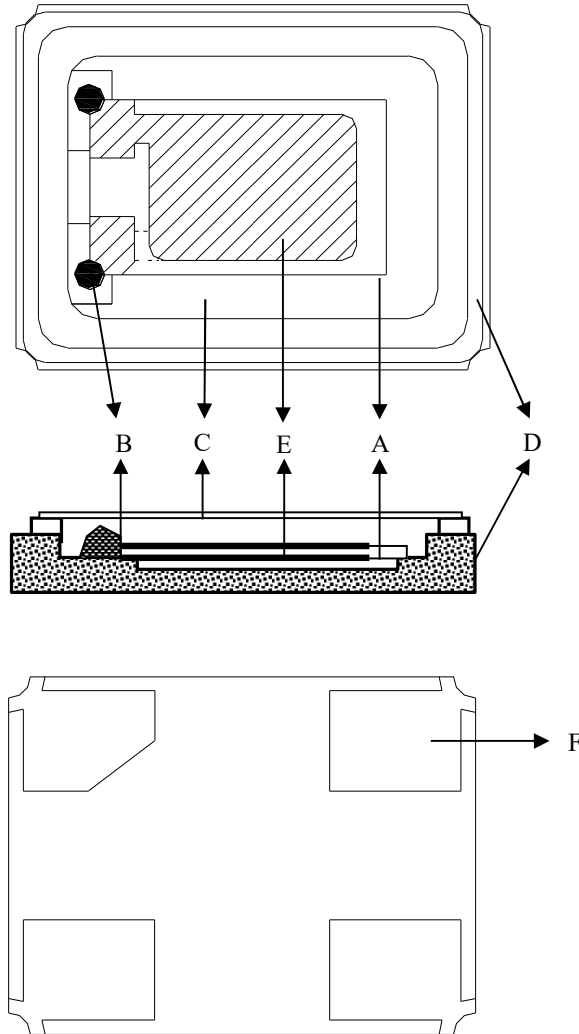

Parts		Material	QTY	COLOR
A	Blank	Mostly SiO ₂	1	White
B	Conductive paste	Ag:80%, silicone resin 10%	2	Greyish
C	Lid	Fe:52~56%,Ni:16~18%,Co:28~30%	1	Silvery
D	Package	Ceramic	1	Brown
E	Plating(blank)	Ag:99.99%	2	Silvery
F	Pad	Cu:6.6%,Au:0.2%,Fe:56%,Ni:18%	4	Golden

5、RELIABILITY SPECIFICATIONS

Item	Conditions	Result
Low Temp. Storage	Put the crystal into the $-40^{\circ}\text{C}\pm 2^{\circ}\text{C}$ constant temperature box for 500 ± 2 H , Measurement taken after 2 hour.	$\Delta F \cong \pm 5$ PPM $\Delta RR \cong \pm 5$ ohms
High Temp. Storage	Put the crystal into the $+100^{\circ}\text{C}\pm 2^{\circ}\text{C}$ constant temperature box for 500 ± 2 H, Measurement taken after 2 hour.	$\Delta F \cong \pm 5$ PPM $\Delta RR \cong \pm 5$ ohms
High Temp & Humidity	Put the crystal into the constant temperature & humid with the temperatures $85^{\circ}\text{C}\pm 3^{\circ}\text{C}$ and the humidity 98% for 500 ± 2 H. Measurement taken after 2 hour.	$\Delta F \cong \pm 5$ PPM $\Delta RR \cong \pm 5$ ohms
Thermal Shock	Put the crystal into the constant temperature $-55^{\circ}\text{C}\pm 2^{\circ}\text{C}$ for 30 ± 1 M, then change the temperature to $+85^{\circ}\text{C}\pm 2^{\circ}\text{C}$ for 30 ± 1 M, the total is 100times. Measurement taken after 2 hour.	$\Delta F \cong \pm 5$ PPM $\Delta RR \cong \pm 5$ ohms
Resistance To Soldering Heat	Passed through the re-flow oven under the following condition. Preheat to $150^{\circ}\text{C}\pm 5^{\circ}\text{C}$ for 60 to 120sec, and peak $265^{\circ}\text{C}\pm 5^{\circ}\text{C}$ for $10\text{s}\pm 3\text{sec}$. Measurement taken after DUT being left at room temperature for at 24 ± 2 hours	$\Delta F \cong \pm 5$ PPM $\Delta RR \cong \pm 5$ ohms
Drop Test	The crystal fall off the cement floor with the height $100\text{cm}\pm 5\text{cm}$ for 3 times. Measurement taken after 2 hour.	$\Delta F \cong \pm 5$ PPM $\Delta RR \cong \pm 5$ ohms
Vibration Test	Apply 0.75mm vibration at sweep frequency $10\sim 500$ Hz, for 2h. 10 cycles in each direction of 3 axis. Measurement taken after 2 hour.	$\Delta F \cong \pm 5$ PPM $\Delta RR \cong \pm 5$ ohms
Shock	Peak 1000m/s^2 , normal width 6ms half sine wave form, 3.7m/s , 3 perpendicular axis of samples, 3 cycles / direction, total 18 cycles. Measurement taken after 2 hour.	$\Delta F \cong \pm 5$ PPM $\Delta RR \cong \pm 5$ ohms
Fine Leak	Helium Bombing 4.5kgf/cm^2 for 2 hr	Less than $1*10^{-8}\text{atm.c.c./sec}$, Helium
Solder ability	In $245 \pm 5^{\circ}\text{C}$ solder bath for 2 ± 0.5 seconds. 8-12X magnifier.	Terminals shall be covered more then 95% with solder.

6、 SUGGESTED REFLOW PROFILE

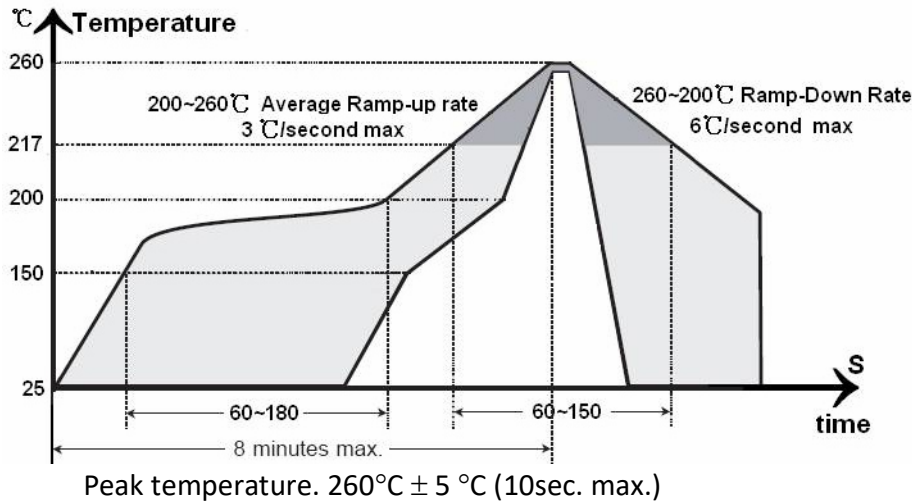

7、 SUBSTANCES IN PRODUCT

Drawing number	Disassembly Unit/component description	Homogeneous Material Name.	Substance Name	CAS No.	Substance Mass. (mg)	Content Rate(%)per
SMD5032	Crystal blank	Quartz	SiO ₂	14808-60-7	1.0131	100.00%
	Electrode	Electrode-Ag	Ag	7440-22-4	0.2332	100.00%
	Package	Ceramics	Al ₂ O ₃	1344-28-1	32.6582	90.00%
			Mn ₂ O ₃	1317-34-6	1.4515	4.00%
			SiO ₂	7631-86-9	1.4515	4.00%
			MoO ₃	1313-27-5	0.3629	1.00%
			MgO	1309-48-4	0.3629	1.00%
			Kovar ring	Fe	7439-89-6	0.4227
		Ni		7440-02-0	0.2313	29.00%
		Co		7440-48-4	0.1436	18.00%
		Plate		Au	7440-57-5	0.2273
			Ni	7440-02-0	0.9690	81.00%
	Metallizing	Mo	7439-98-7	0.3988	100.00%	
	Solder	Ag	7440-22-4	0.8494	71.00%	
		Cu	7440-50-8	0.3469	29.00%	
	Lid	Kovar	Fe	7439-89-6	13.5809	48.50%
			Ni	7440-02-0	9.8006	35.00%
			Co	7440-48-4	4.4803	16.00%
			Mn	7439-96-5	0.1400	0.50%
	Conduct Adhesive	silver adhesive	Ag	7440-22-4	0.6134	70.00%
			Pd	7440-05-3	0.0438	5.00%
C ₁₁ H ₂₄			1120-21-4	0.0876	10.00%	
C ₁₂ H ₂₆			112-40-3	0.0438	5.00%	
SiO ₂			7631-86-9	0.0876	10.00%	

All the products we provide meet the requirements of RoHS and Reach regulations, and we send SGS for ICP test every year.

8、PACKING SPECIFICATIONS (Unit: mm)

TAPE SPECIFICATION :

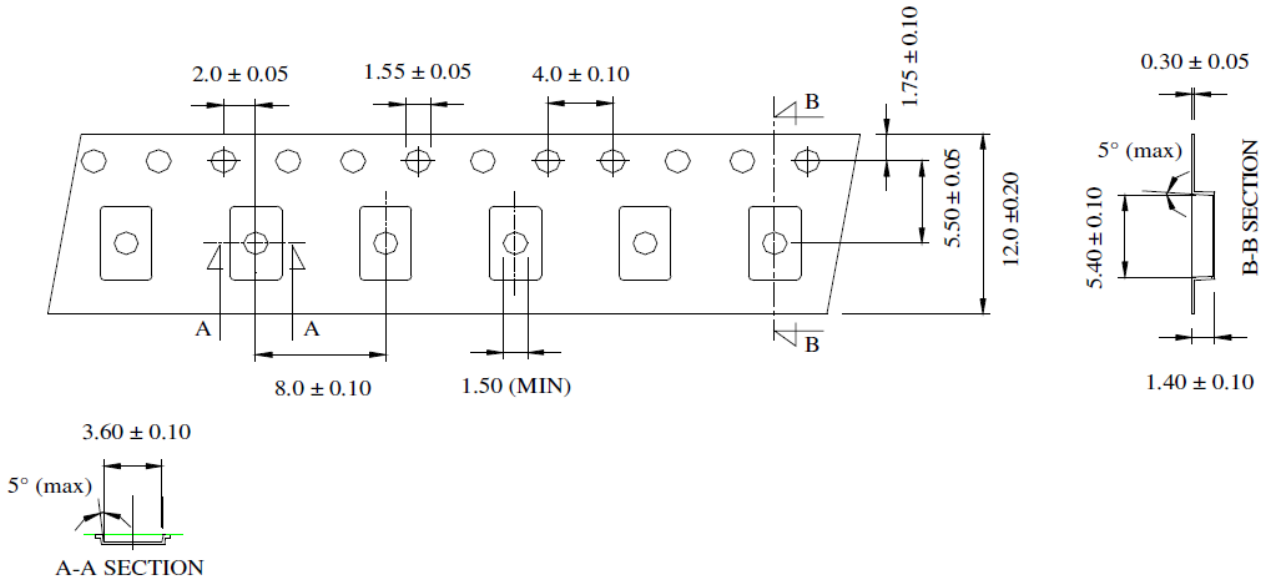

OUTLINE DIMENSION

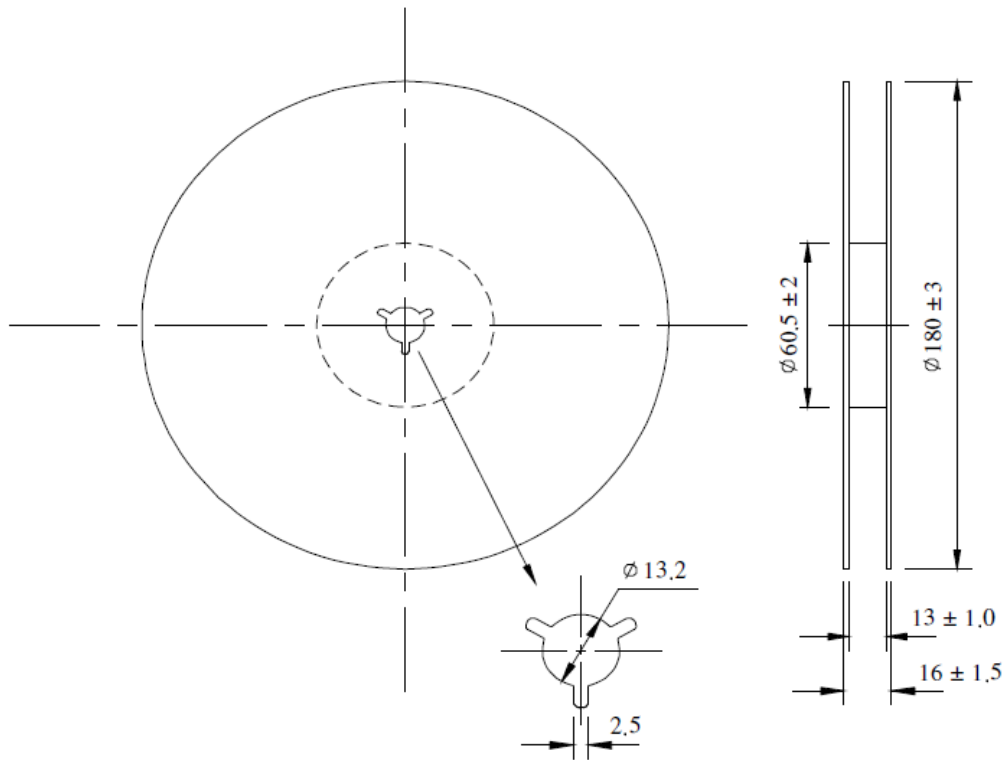

Q'ty: 1000pcs/Reel

Series TX5, P/N: WTL5M95453PH
SMD Seam Sealed Crystals 5.0×3.2 mm



9、WTL PART NUMBER SYSTEM :

For example: WTL5M37189MW

[Instructions: for project management, WTL will trace back the part number to developer wherever it goes]

WTL - 5M - 37189 - MW

WTL: Brand

5M : Package Code

37189: Serial number , flow code , without any rules

MW: WTL Developer Code, for example: VH,CH,PZ,RZ,ML