

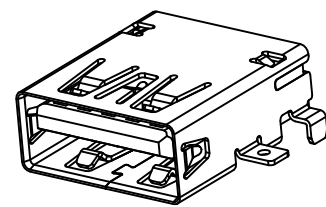

REV.	ECN NO.	DESCRIPTION	DWN.	APVD.	DATE
X1	N/A	Initial release	WTC	DLQ	2019.10.31

- NOTES:
- MATERIAL AND PLATING:**
Housing: PA9T+30%G.F,UL94V-0,BLUE
Contact: Phosphor Bronze,Au And Sn Plated.
Shell: Stainless Steel,Ni Plated.
 - MECHANICAL CHARACTERISTIC**
Mating Force: 35N(3.57Kgf) Max.
Unmating Force: 10N(1.02Kgf) Min.
Durability: 5,000 Cycles.
 - ELECTRICAL CHARACTERISTIC**
Current Rating: 1.8A(Pin1,4),
0.25A For Other Contacts.
Voltage Rating: 30V AC Max.
Contact Resistance: 30m Ohm Max.
Insulation Resistance: 100M Ohm Min.
Dielectric Withstanding Voltage: 100V AC.
 - TEMPERATURE**
Operating Temperature: -40°C~+85°C
Storage Temperature: -60°C~+105°C
 - DATECODE INFORMATION:**
YYMMDD (Y:YEAR M:MONTH D:DATE)

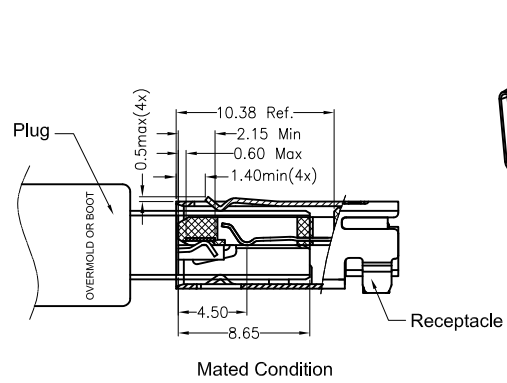
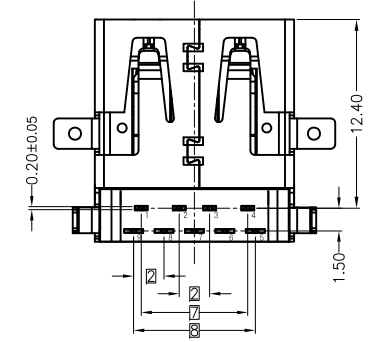
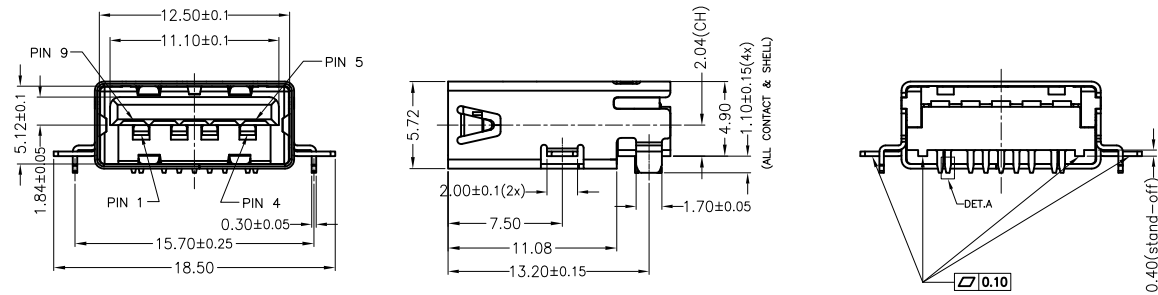
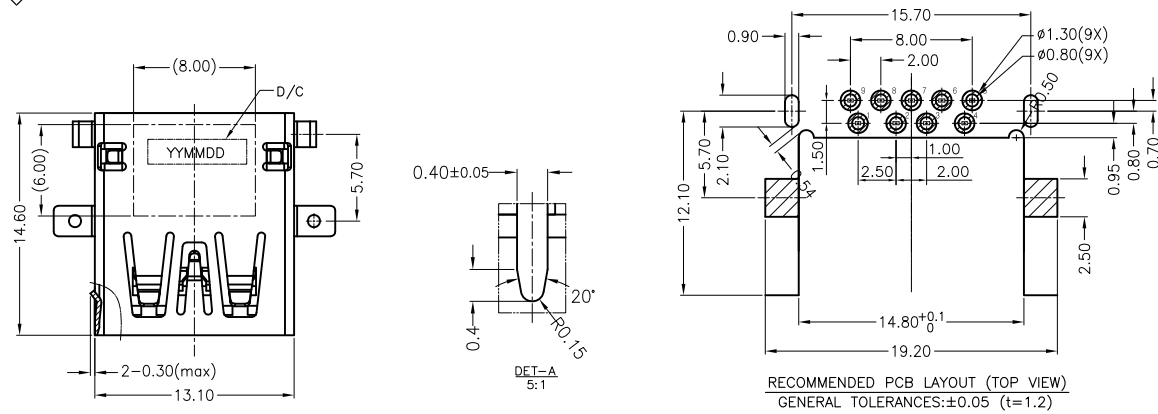

ORDERING INFORMATION
US0905***0498

MATRICAL:
5=PA9T+30%G.F

COLOR:
U=BLUE

PLATING:
A=G/F

Contact Number	Signal Name
PIN1	VBUS
PIN2	D-
PIN3	D+
PIN4	GND
PIN5	StdA_SSRX-
PIN6	StdA_SSRX+
PIN7	GND_DRAIN
PIN8	StdA_SSTX-
PIN9	StdA_SSTX+
Shell	Shield

THE RESTRICTION OF ENVIRONMENTAL MANAGEMENT SUBSTANCES IS
BASED ON THE NEW VERSION OF HTQ-S-3Q-83

TITLE: USB3.0 AF R/A DIP TYPE CH=2.04		HOMETOM www.hometom.com.tw HORNG TONG ENTERPRISE CO.,LTD.	
TOLERANCE		APPROVAL:	UNIT: mm
LINEAR: X.X ±0.30 .XX ±0.20 .XXX ±0.10	ANGLE: X° ±2° .X° ±1° .XX° ±0.5°	CHECK:	PART NO: US0905***0498
CUSTOMER DRAWING	REV: X1	DRAWN:	SIZE: A4 DWG.NO: CUS415-00
		SCALE: 1:1	PRJ.: SHEET: 1 / 1