



SN74HC/HCT85(LX) 4-bit Magnitude Comparator

Product Specification

Specification Revision History:

Version	Date	Description
2022-06-A1	2022-06	New
2023-04-B1	2023-04	Update the template



Contents

1、 General Description.....	3
2、 Block Diagram And Pin Description	6
2.1、 Block Diagram	6
2.2、 Pin Configurations.....	7
2.3、 Pin Description	8
2.4、 Function Table.....	8
3、 Electrical Parameter	9
3.1、 Absolute Maximum Ratings.....	9
3.2、 Recommended Operating Conditions	9
3.3、 Electrical Characteristics	10
3.3.1、 DC Characteristics 1	10
3.3.2、 DC Characteristics 2	11
3.3.3、 DC Characteristics 3	12
3.3.4、 AC Characteristics 1	13
3.3.5、 AC Characteristics 2	14
3.3.6、 AC Characteristics 3	15
4、 Testing Circuit	16
4.1、 AC Testing Circuit	16
4.2、 AC Testing Waveforms.....	16
4.3、 Measurement Points	16
4.4、 Test Data	16
5、 Package Information	17
5.1、 DIP16	17
5.2、 SOP16	18
5.3、 TSSOP16.....	19
6、 Statements And Notes	20
6.1、 The name and content of Hazardous substances or Elements in the product	20
6.2、 Notes	20



灵星芯微 集成电路

1、General Description

The SN74HC/HCT85 is a 4-bit magnitude comparator that can be expanded to almost any length. They perform comparison of two 4-bit binary, BCD or other monotonic codes and present the three possible magnitude results at the outputs ($Q_{A>B}$, $Q_{A=B}$ and $Q_{A<B}$). The 4-bit inputs are weighted (A0 to A3 and B0 to B3), where A3 and B3 are the most significant bits. For proper compare operation the expander inputs ($I_{A>B}$, $I_{A=B}$ and $I_{A<B}$) to the least significant position must be connected as follows: $I_{A<B}=I_{A>B}=\text{LOW}$ and $I_{A=B}=\text{HIGH}$. For words greater than 4-bits, units can be cascaded by connecting outputs $Q_{A>B}$, $Q_{A=B}$ and $Q_{A<B}$ to the corresponding inputs of the significant comparator. Inputs include clamp diodes. This enables the use of current limiting resistors to interface inputs to voltages in excess of V_{CC} .

Features:

- CMOS low power dissipation
- Input levels:
 - For SN74HC85: CMOS level
 - For SN74HCT85: TTL level
- Specified from -40°C to $+125^{\circ}\text{C}$
- Packaging information: DIP16/SOP16/TSSOP16



灵星芯微 精密制程

Ordering Information:**Tube packing specifications:**

Part number	Packaging form	Marking code	Tube quantity	Boxed tube quantity	Boxed quantity	Notes
SN74HC85N(LX)	DIP16	SN74HC85N	25 PCS/tube	40 tube/box	1000 PCS/box	Dimensions of plastic enclosure: 19.0mm×6.4mm Pin spacing: 2.54mm
SN74HCT85N(LX)	DIP16	SN74HCT85N	25 PCS/tube	40 tube/box	1000 PCS/box	Dimensions of plastic enclosure: 19.0mm×6.4mm Pin spacing: 2.54mm
SN74HC85DR(LX)	SOP16	HC85	50 PCS/tube	200 tube/box	10000 PCS/box	Dimensions of plastic enclosure: 10.0mm×3.9mm Pin spacing: 1.27mm
SN74HCT85DR(LX)	SOP16	HCT85	50 PCS/tube	200 tube/box	10000 PCS/box	Dimensions of plastic enclosure: 10.0mm×3.9mm Pin spacing: 1.27mm
SN74HC85PW(LX)	TSSOP16	HC85	96 PCS/tube	200 tube/box	19200 PCS/box	Dimensions of plastic enclosure: 5.0mm×4.4mm Pin spacing: 0.65mm
SN74HCT85PW(LX)	TSSOP16	HCT85	96 PCS/tube	200 tube/box	19200 PCS/box	Dimensions of plastic enclosure: 5.0mm×4.4mm Pin spacing: 0.65mm



Reel packing specifications:

Part number	Packaging form	Marking code	Reel quantity	Boxed reel quantity	Notes
SN74HC85DR(LX)	SOP16	HC85	2500 PCS/reel	5000 PCS/box	Dimensions of plastic enclosure: 10.0mm×3.9mm Pin spacing:1.27mm
SN74HCT85DR(LX)	SOP16	HCT85	2500 PCS/reel	5000 PCS/box	Dimensions of plastic enclosure: 10.0mm×3.9mm Pin spacing:1.27mm
SN74HC85PW(LX)	TSSOP16	HC85	5000 PCS/reel	10000 PCS/box	Dimensions of plastic enclosure: 5.0mm×4.4mm Pin spacing:0.65mm
SN74HCT85PW(LX)	TSSOP16	HCT85	5000 PCS/reel	10000 PCS/box	Dimensions of plastic enclosure: 5.0mm×4.4mm Pin spacing:0.65mm

Note: If the physical information is inconsistent with the ordering information, please refer to the actual product.



2、Block Diagram And Pin Description

2.1、Block Diagram

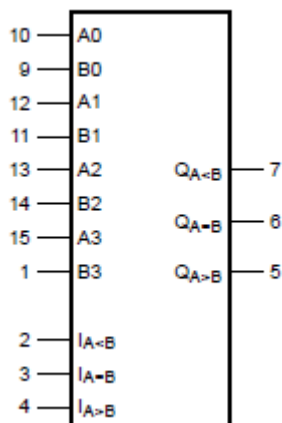

Figure 1. Logic symbol

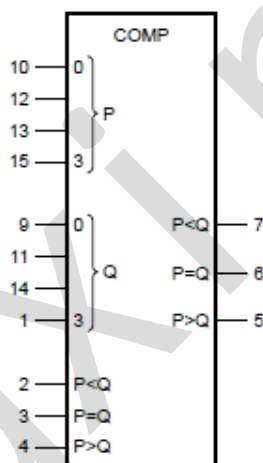

Figure 2. IEC logic symbol

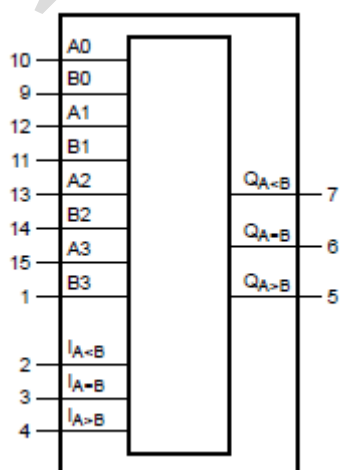

Figure 3. Functional diagram

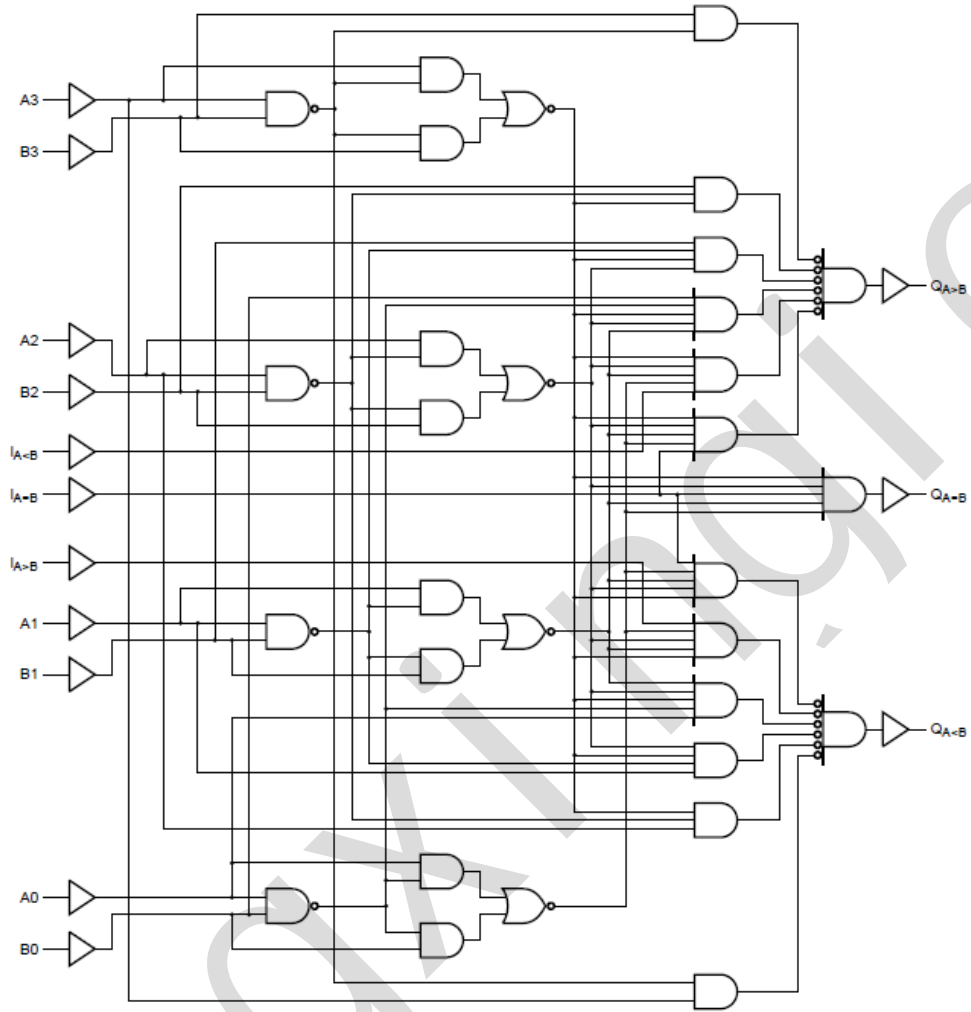
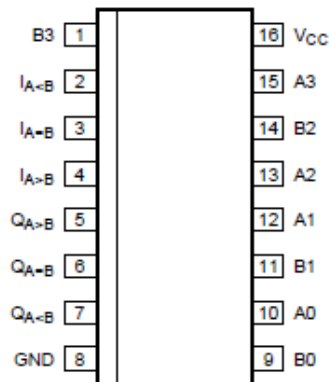

Figure 4. Logic diagram

2.2. Pin Configurations





2.3、Pin Description

Pin No.	Pin Name	Description
1	B3	word B input
2	I _{A<B}	A<B expansion input
3	I _{A=B}	A=B expansion input
4	I _{A>B}	A>B expansion input
5	Q _{A>B}	A>B output
6	Q _{A=B}	A=B output
7	Q _{A<B}	A<B output
8	GND	ground (0V)
9	B0	word B input
10	A0	word A input
11	B1	word B input
12	A1	word A input
13	A2	word A input
14	B2	word B input
15	A3	word A input
16	V _{CC}	supply voltage

2.4、Function Table

Comparing input				Cascading input			Output		
A3, B3	A2, B2	A1, B1	A0, B0	I _{A>B}	I _{A<B}	I _{A=B}	Q _{A>B}	Q _{A<B}	Q _{A=B}
A3>B3	X	X	X	X	X	X	H	L	L
A3<B3	X	X	X	X	X	X	L	H	L
A3=B3	A2>B2	X	X	X	X	X	H	L	L
A3=B3	A2<B2	X	X	X	X	X	L	H	L
A3=B3	A2=B2	A1>B1	X	X	X	X	H	L	L
A3=B3	A2=B2	A1<B1	X	X	X	X	L	H	L
A3=B3	A2=B2	A1=B1	A0>B0	X	X	X	H	L	L
A3=B3	A2=B2	A1=B1	A0<B0	X	X	X	L	H	L
A3=B3	A2=B2	A1=B1	A0=B0	H	L	L	H	L	L
A3=B3	A2=B2	A1=B1	A0=B0	L	H	L	L	H	L
A3=B3	A2=B2	A1=B1	A0=B0	L	L	H	L	L	H
A3=B3	A2=B2	A1=B1	A0=B0	X	X	H	L	L	H
A3=B3	A2=B2	A1=B1	A0=B0	H	H	L	L	L	L
A3=B3	A2=B2	A1=B1	A0=B0	L	L	L	H	H	L

Note: H=HIGH voltage level; L=LOW voltage level; X=don't care.



3、Electrical Parameter

3.1、Absolute Maximum Ratings

(Voltages are referenced to GND (ground=0V), unless otherwise specified.)

Parameter	Symbol	Conditions	Min.	Max.	Unit
supply voltage	V_{CC}	-	-0.5	+7.0	V
input clamping current	I_{IK}	$V_I < -0.5V$ or $V_I > V_{CC}+0.5V$	-	± 20	mA
output clamping current	I_{OK}	$V_O < -0.5V$ or $V_O > V_{CC}+0.5V$	-	± 20	mA
output current	I_O	$-0.5V < V_O < V_{CC}+0.5V$	-	± 25	mA
supply current	I_{CC}	-	-	50	mA
ground current	I_{GND}	-	-50	-	mA
storage temperature	T_{stg}	-	-65	+150	$^{\circ}C$
total power dissipation	P_{tot}	-	-	500	mW
soldering temperature	T_L	10s	DIP	245	$^{\circ}C$
			SOP/TSSOP	260	

3.2、Recommended Operating Conditions

Parameter	Symbol	Conditions	Min.	Typ.	Max.	Unit
SN74HC85						
supply voltage	V_{CC}	-	2.0	5.0	6.0	V
input voltage	V_I	-	0	-	V_{CC}	V
output voltage	V_O	-	0	-	V_{CC}	V
input transition rise and fall rate	$\Delta t/\Delta V$	$V_{CC}=2.0V$	-	-	625	ns/V
		$V_{CC}=4.5V$	-	1.67	139	ns/V
		$V_{CC}=6.0V$	-	-	83	ns/V
ambient temperature	T_{amb}	-	-40	-	+125	$^{\circ}C$
SN74HCT85						
supply voltage	V_{CC}	-	4.5	5.0	5.5	V
input voltage	V_I	-	0	-	V_{CC}	V
output voltage	V_O	-	0	-	V_{CC}	V
input transition rise and fall rate	$\Delta t/\Delta V$	$V_{CC}=2.0V$	-	-	-	ns/V
		$V_{CC}=4.5V$	-	1.67	139	ns/V
		$V_{CC}=6.0V$	-	-	-	ns/V
ambient temperature	T_{amb}	-	-40	-	+125	$^{\circ}C$



3.3、Electrical Characteristics

3.3.1、DC Characteristics 1

($T_{amb}=25^{\circ}C$, voltages are referenced to GND (ground=0V), unless otherwise specified.)

Parameter	Symbol	Conditions	Min.	Typ.	Max.	Unit	
SN74HC85							
HIGH-level input voltage	V_{IH}	$V_{CC}=2.0V$	1.5	1.2	-	V	
		$V_{CC}=4.5V$	3.15	2.4	-	V	
		$V_{CC}=6.0V$	4.2	3.2	-	V	
LOW-level input voltage	V_{IL}	$V_{CC}=2.0V$	-	0.8	0.5	V	
		$V_{CC}=4.5V$	-	2.1	1.35	V	
		$V_{CC}=6.0V$	-	2.8	1.8	V	
HIGH-level output voltage	V_{OH}	$V_I=V_{IH}$ or V_{IL}	$I_O=-20\mu A; V_{CC}=2.0V$	1.9	2.0	-	V
			$I_O=-20\mu A; V_{CC}=4.5V$	4.4	4.5	-	V
			$I_O=-20\mu A; V_{CC}=6.0V$	5.9	6.0	-	V
			$I_O=-4.0mA; V_{CC}=4.5V$	3.98	4.32	-	V
			$I_O=-5.2mA; V_{CC}=6.0V$	5.48	5.81	-	V
LOW-level output voltage	V_{OL}	$V_I=V_{IH}$ or V_{IL}	$I_O=20\mu A; V_{CC}=2.0V$	-	0	0.1	V
			$I_O=20\mu A; V_{CC}=4.5V$	-	0	0.1	V
			$I_O=20\mu A; V_{CC}=6.0V$	-	0	0.1	V
			$I_O=4.0mA; V_{CC}=4.5V$	-	0.15	0.26	V
			$I_O=5.2mA; V_{CC}=6.0V$	-	0.16	0.26	V
input leakage current	I_I	$V_I=V_{CC}$ or GND; $V_{CC}=6.0V$	-	-	± 1.0	μA	
supply current	I_{CC}	$V_I=V_{CC}$ or GND; $I_O=0A; V_{CC}=6.0V$	-	-	8.0	μA	
input capacitance	C_I	-	-	3.5	-	pF	
SN74HCT85							
HIGH-level input voltage	V_{IH}	$V_{CC}=4.5V$ to $5.5V$	2.0	1.6	-	V	
LOW-level input voltage	V_{IL}	$V_{CC}=4.5V$ to $5.5V$	-	1.2	0.8	V	
HIGH-level output voltage	V_{OH}	$V_I=V_{IH}$ or $V_{IL}; V_{CC}=4.5V$	$I_O=-20\mu A$	4.4	4.5	-	V
			$I_O=-4.0mA$	3.98	4.32	-	V
LOW-level output voltage	V_{OL}	$V_I=V_{IH}$ or $V_{IL}; V_{CC}=4.5V$	$I_O=20\mu A$	-	0	0.1	V
			$I_O=4.0mA$	-	0.15	0.26	V
input leakage current	I_I	$V_I=V_{CC}$ or GND; $V_{CC}=5.5V$	-	-	± 1.0	μA	
supply current	I_{CC}	$V_I=V_{CC}$ or GND; $I_O=0A; V_{CC}=5.5V$	-	-	8.0	μA	
additional supply current	ΔI_{CC}	per input pin; $V_I=V_{CC}-2.1V$; other inputs at V_{CC} or GND; $I_O=0A; V_{CC}=4.5V$ to $5.5V$	$I_{A<B}$ and $I_{A>B}$ inputs	-	-	360	μA
			A_n, B_n and $I_{A=B}$ inputs	-	-	540	μA
input capacitance	C_I	-	-	3.5	-	pF	



3.3.2、DC Characteristics 2

($T_{amb}=-40^{\circ}\text{C}$ to $+85^{\circ}\text{C}$, voltages are referenced to GND (ground=0V), unless otherwise specified.)

Parameter	Symbol	Conditions	Min.	Typ.	Max.	Unit	
SN74HC85							
HIGH-level input voltage	V_{IH}	$V_{CC}=2.0\text{V}$	1.5	-	-	V	
		$V_{CC}=4.5\text{V}$	3.15	-	-	V	
		$V_{CC}=6.0\text{V}$	4.2	-	-	V	
LOW-level input voltage	V_{IL}	$V_{CC}=2.0\text{V}$	-	-	0.5	V	
		$V_{CC}=4.5\text{V}$	-	-	1.35	V	
		$V_{CC}=6.0\text{V}$	-	-	1.8	V	
HIGH-level output voltage	V_{OH}	$V_I=V_{IH}$ or V_{IL}	$I_O=-20\mu\text{A}; V_{CC}=2.0\text{V}$	1.9	-	-	V
			$I_O=-20\mu\text{A}; V_{CC}=4.5\text{V}$	4.4	-	-	V
			$I_O=-20\mu\text{A}; V_{CC}=6.0\text{V}$	5.9	-	-	V
			$I_O=-4.0\text{mA}; V_{CC}=4.5\text{V}$	3.84	-	-	V
			$I_O=-5.2\text{mA}; V_{CC}=6.0\text{V}$	5.34	-	-	V
LOW-level output voltage	V_{OL}	$V_I=V_{IH}$ or V_{IL}	$I_O=20\mu\text{A}; V_{CC}=2.0\text{V}$	-	-	0.1	V
			$I_O=20\mu\text{A}; V_{CC}=4.5\text{V}$	-	-	0.1	V
			$I_O=20\mu\text{A}; V_{CC}=6.0\text{V}$	-	-	0.1	V
			$I_O=4.0\text{mA}; V_{CC}=4.5\text{V}$	-	-	0.33	V
			$I_O=5.2\text{mA}; V_{CC}=6.0\text{V}$	-	-	0.33	V
input leakage current	I_I	$V_I=V_{CC}$ or GND; $V_{CC}=6.0\text{V}$	-	-	± 1.0	μA	
supply current	I_{CC}	$V_I=V_{CC}$ or GND; $I_O=0\text{A}; V_{CC}=6.0\text{V}$	-	-	80	μA	
SN74HCT85							
HIGH-level input voltage	V_{IH}	$V_{CC}=4.5\text{V}$ to 5.5V	2.0	-	-	V	
LOW-level input voltage	V_{IL}	$V_{CC}=4.5\text{V}$ to 5.5V	-	-	0.8	V	
HIGH-level output voltage	V_{OH}	$V_I=V_{IH}$ or $V_{IL}; V_{CC}=4.5\text{V}$	$I_O=-20\mu\text{A}$	4.4	-	-	V
			$I_O=-4.0\text{mA}$	3.84	-	-	V
LOW-level output voltage	V_{OL}	$V_I=V_{IH}$ or $V_{IL}; V_{CC}=4.5\text{V}$	$I_O=20\mu\text{A}$	-	-	0.1	V
			$I_O=4.0\text{mA}$	-	-	0.33	V
input leakage current	I_I	$V_I=V_{CC}$ or GND; $V_{CC}=5.5\text{V}$	-	-	± 1.0	μA	
supply current	I_{CC}	$V_I=V_{CC}$ or GND; $I_O=0\text{A}; V_{CC}=5.5\text{V}$	-	-	80	μA	
additional supply current	ΔI_{CC}	per input pin; $V_I=V_{CC}-2.1\text{V};$ other inputs at V_{CC} or GND; $I_O=0\text{A}; V_{CC}=4.5\text{V}$ to 5.5V	$I_{A<B}$ and $I_{A>B}$ inputs	-	-	450	μA
			A_n, B_n and $I_{A=B}$ inputs	-	-	675	μA



3.3.3、DC Characteristics 3

($T_{amb}=-40^{\circ}\text{C}$ to $+125^{\circ}\text{C}$, voltages are referenced to GND (ground=0V), unless otherwise specified.)

Parameter	Symbol	Conditions	Min.	Typ.	Max.	Unit	
SN74HC85							
HIGH-level input voltage	V_{IH}	$V_{CC}=2.0\text{V}$	1.5	-	-	V	
		$V_{CC}=4.5\text{V}$	3.15	-	-	V	
		$V_{CC}=6.0\text{V}$	4.2	-	-	V	
LOW-level input voltage	V_{IL}	$V_{CC}=2.0\text{V}$	-	-	0.5	V	
		$V_{CC}=4.5\text{V}$	-	-	1.35	V	
		$V_{CC}=6.0\text{V}$	-	-	1.8	V	
HIGH-level output voltage	V_{OH}	$V_I=V_{IH}$ or V_{IL}	$I_O=-20\mu\text{A}; V_{CC}=2.0\text{V}$	1.9	-	-	V
			$I_O=-20\mu\text{A}; V_{CC}=4.5\text{V}$	4.4	-	-	V
			$I_O=-20\mu\text{A}; V_{CC}=6.0\text{V}$	5.9	-	-	V
			$I_O=-4.0\text{mA}; V_{CC}=4.5\text{V}$	3.7	-	-	V
			$I_O=-5.2\text{mA}; V_{CC}=6.0\text{V}$	5.2	-	-	V
LOW-level output voltage	V_{OL}	$V_I=V_{IH}$ or V_{IL}	$I_O=20\mu\text{A}; V_{CC}=2.0\text{V}$	-	-	0.1	V
			$I_O=20\mu\text{A}; V_{CC}=4.5\text{V}$	-	-	0.1	V
			$I_O=20\mu\text{A}; V_{CC}=6.0\text{V}$	-	-	0.1	V
			$I_O=4.0\text{mA}; V_{CC}=4.5\text{V}$	-	-	0.4	V
			$I_O=5.2\text{mA}; V_{CC}=6.0\text{V}$	-	-	0.4	V
input leakage current	I_I	$V_I=V_{CC}$ or GND; $V_{CC}=6.0\text{V}$	-	-	± 1.0	μA	
supply current	I_{CC}	$V_I=V_{CC}$ or GND; $I_O=0\text{A}; V_{CC}=6.0\text{V}$	-	-	160	μA	
SN74HCT85							
HIGH-level input voltage	V_{IH}	$V_{CC}=4.5\text{V}$ to 5.5V	2.0	-	-	V	
LOW-level input voltage	V_{IL}	$V_{CC}=4.5\text{V}$ to 5.5V	-	-	0.8	V	
HIGH-level output voltage	V_{OH}	$V_I=V_{IH}$ or $V_{IL}; V_{CC}=4.5\text{V}$	$I_O=-20\mu\text{A}$	4.4	-	-	V
			$I_O=-4.0\text{mA}$	3.7	-	-	V
LOW-level output voltage	V_{OL}	$V_I=V_{IH}$ or $V_{IL}; V_{CC}=4.5\text{V}$	$I_O=20\mu\text{A}$	-	-	0.1	V
			$I_O=4.0\text{mA}$	-	-	0.4	V
input leakage current	I_I	$V_I=V_{CC}$ or GND; $V_{CC}=5.5\text{V}$	-	-	± 1.0	μA	
supply current	I_{CC}	$V_I=V_{CC}$ or GND; $I_O=0\text{A}; V_{CC}=5.5\text{V}$	-	-	160	μA	
additional supply current	ΔI_{CC}	per input pin; $V_I=V_{CC}-2.1\text{V};$ other inputs at V_{CC} or GND; $I_O=0\text{A}; V_{CC}=4.5\text{V}$ to 5.5V	$I_{A<B}$ and $I_{A>B}$ inputs	-	-	490	μA
			An, Bn and $I_{A=B}$ inputs	-	-	735	μA



3.3.4、AC Characteristics 1

($T_{amb}=25^{\circ}\text{C}$, $GND=0\text{V}$, $C_L=50\text{pF}$, unless otherwise specified.)

Parameter	Symbol	Conditions	Min.	Typ.	Max.	Unit	
SN74HC85							
propagation delay	t_{pd}	An, Bn to $Q_{A>B}$; An, Bn to $Q_{A<B}$; see Figure 6 ^[1]	$V_{CC}=2.0\text{V}$	-	63	195	ns
			$V_{CC}=4.5\text{V}$	-	23	39	ns
			$V_{CC}=5.0\text{V}; C_L=15\text{pF}$	-	20	-	ns
			$V_{CC}=6.0\text{V}$	-	18	33	ns
		An, Bn to $Q_{A=B}$; see Figure 6	$V_{CC}=2.0\text{V}$	-	58	175	ns
			$V_{CC}=4.5\text{V}$	-	21	35	ns
			$V_{CC}=5.0\text{V}; C_L=15\text{pF}$	-	18	-	ns
			$V_{CC}=6.0\text{V}$	-	17	30	ns
		$I_{A=B}$ or $I_{A>B}$ to $Q_{A<B}$; $I_{A<B}$ or $I_{A=B}$ to $Q_{A>B}$; see Figure 6	$V_{CC}=2.0\text{V}$	-	50	140	ns
			$V_{CC}=4.5\text{V}$	-	18	28	ns
			$V_{CC}=5.0\text{V}; C_L=15\text{pF}$	-	15	-	ns
			$V_{CC}=6.0\text{V}$	-	14	24	ns
		$I_{A=B}$ to $Q_{A=B}$; see Figure 6	$V_{CC}=2.0\text{V}$	-	39	120	ns
			$V_{CC}=4.5\text{V}$	-	14	24	ns
			$V_{CC}=5.0\text{V}; C_L=15\text{pF}$	-	11	-	ns
			$V_{CC}=6.0\text{V}$	-	11	20	ns
transition time	t_t	see Figure 6 ^[2]	$V_{CC}=2.0\text{V}$	-	19	75	ns
			$V_{CC}=4.5\text{V}$	-	7	15	ns
			$V_{CC}=6.0\text{V}$	-	6	13	ns
power dissipation capacitance	C_{PD}	per package; $V_I=GND$ to V_{CC} ^[3]	-	18	-	pF	
SN74HCT85							
propagation delay	t_{pd}	An, Bn to $Q_{A>B}$; An, Bn to $Q_{A<B}$; see Figure 6 ^[1]	$V_{CC}=4.5\text{V}$	-	26	44	ns
			$V_{CC}=5.0\text{V}; C_L=15\text{pF}$	-	22	-	ns
		An, Bn to $Q_{A=B}$; see Figure 6	$V_{CC}=4.5\text{V}$	-	24	40	ns
			$V_{CC}=5.0\text{V}; C_L=15\text{pF}$	-	20	-	ns
		$I_{A=B}$ or $I_{A>B}$ to $Q_{A<B}$; $I_{A<B}$ or $I_{A=B}$ to $Q_{A>B}$; see Figure 6	$V_{CC}=4.5\text{V}$	-	18	31	ns
			$V_{CC}=5.0\text{V}; C_L=15\text{pF}$	-	15	-	ns
		$I_{A=B}$ to $Q_{A=B}$; see Figure 6	$V_{CC}=4.5\text{V}$	-	18	31	ns
			$V_{CC}=5.0\text{V}; C_L=15\text{pF}$	-	15	-	ns
transition time	t_t	$V_{CC}=4.5\text{V}$; see Figure 6 ^[2]	-	7	15	ns	
power dissipation capacitance	C_{PD}	per package; $V_I=GND$ to $V_{CC}-1.5\text{V}$ ^[3]	-	20	-	pF	

Note:

[1] t_{pd} is the same as t_{PLH} and t_{PHL} .

[2] t_t is the same as t_{THL} and t_{TLH} .

[3] C_{PD} is used to determine the dynamic power dissipation (P_D in uW).

$$P_D=C_{PD}\times V_{CC}^2\times f_i+\sum(C_L\times V_{CC}^2\times f_o) \text{ where:}$$



f_i =input frequency in MHz; f_o =output frequency in MHz;

C_L =output load capacitance in pF;

V_{CC} =supply voltage in V;

$\sum(C_L \times V_{CC}^2 \times f_o)$ =sum of outputs.

3.3.5、AC Characteristics 2

(T_{amb} =-40°C to +85°C, GND =0V, C_L =50pF, unless otherwise specified.)

Parameter	Symbol	Conditions	Min.	Typ.	Max.	Unit	
SN74HC85							
propagation delay	t_{pd}	An, Bn to $Q_{A>B}$; An, Bn to $Q_{A<B}$; see Figure 6 ^[1]	$V_{CC}=2.0V$	-	-	245	ns
			$V_{CC}=4.5V$	-	-	49	ns
			$V_{CC}=6.0V$	-	-	42	ns
		An, Bn to $Q_{A=B}$; see Figure 6	$V_{CC}=2.0V$	-	-	220	ns
			$V_{CC}=4.5V$	-	-	44	ns
			$V_{CC}=6.0V$	-	-	37	ns
		$I_{A=B}$ or $I_{A>B}$ to $Q_{A<B}$; $I_{A<B}$ or $I_{A=B}$ to $Q_{A>B}$; see Figure 6	$V_{CC}=2.0V$	-	-	175	ns
			$V_{CC}=4.5V$	-	-	35	ns
			$V_{CC}=6.0V$	-	-	30	ns
		$I_{A=B}$ to $Q_{A=B}$; see Figure 6	$V_{CC}=2.0V$	-	-	150	ns
			$V_{CC}=4.5V$	-	-	30	ns
			$V_{CC}=6.0V$	-	-	26	ns
transition time	t_t	see Figure 6 ^[2]	$V_{CC}=2.0V$	-	-	95	ns
			$V_{CC}=4.5V$	-	-	19	ns
			$V_{CC}=6.0V$	-	-	16	ns
SN74HCT85							
propagation delay	t_{pd}	An, Bn to $Q_{A>B}$; An, Bn to $Q_{A<B}$; see Figure 6 ^[1]	$V_{CC}=4.5V$	-	-	55	ns
			$V_{CC}=4.5V$	-	-	50	ns
		$I_{A=B}$ or $I_{A>B}$ to $Q_{A<B}$; $I_{A<B}$ or $I_{A=B}$ to $Q_{A>B}$; see Figure 6	$V_{CC}=4.5V$	-	-	39	ns
			$V_{CC}=4.5V$	-	-	39	ns
transition time	t_t	$V_{CC}=4.5V$; see Figure 6 ^[2]	-	-	19	ns	

Note:

[1] t_{pd} is the same as t_{PLH} and t_{PHL} .

[2] t_t is the same as t_{THL} and t_{TLH} .



3.3.6、AC Characteristics 3

($T_{amb}=-40^{\circ}\text{C}$ to $+125^{\circ}\text{C}$, $\text{GND}=0\text{V}$, $C_L=50\text{pF}$, unless otherwise specified.)

Parameter	Symbol	Conditions	Min.	Typ.	Max.	Unit	
SN74HC85							
propagation delay	t_{pd}	An, Bn to $Q_{A>B}$; An, Bn to $Q_{A<B}$; see Figure 6 ^[1]	$V_{CC}=2.0\text{V}$	-	-	295	ns
			$V_{CC}=4.5\text{V}$	-	-	59	ns
			$V_{CC}=6.0\text{V}$	-	-	50	ns
		An, Bn to $Q_{A=B}$; see Figure 6	$V_{CC}=2.0\text{V}$	-	-	265	ns
			$V_{CC}=4.5\text{V}$	-	-	53	ns
			$V_{CC}=6.0\text{V}$	-	-	45	ns
		$I_{A=B}$ or $I_{A>B}$ to $Q_{A<B}$; $I_{A<B}$ or $I_{A=B}$ to $Q_{A>B}$; see Figure 6	$V_{CC}=2.0\text{V}$	-	-	210	ns
			$V_{CC}=4.5\text{V}$	-	-	42	ns
			$V_{CC}=6.0\text{V}$	-	-	36	ns
		$I_{A=B}$ to $Q_{A=B}$; see Figure 6	$V_{CC}=2.0\text{V}$	-	-	180	ns
$V_{CC}=4.5\text{V}$	-		-	36	ns		
$V_{CC}=6.0\text{V}$	-		-	31	ns		
transition time	t_t	see Figure 6 ^[2]	$V_{CC}=2.0\text{V}$	-	-	110	ns
			$V_{CC}=4.5\text{V}$	-	-	22	ns
			$V_{CC}=6.0\text{V}$	-	-	19	ns
SN74HCT85							
propagation delay	t_{pd}	An, Bn to $Q_{A>B}$; An, Bn to $Q_{A<B}$; see Figure 6 ^[1]	$V_{CC}=4.5\text{V}$	-	-	66	ns
			$V_{CC}=4.5\text{V}$	-	-	60	ns
		$I_{A=B}$ or $I_{A>B}$ to $Q_{A<B}$; $I_{A<B}$ or $I_{A=B}$ to $Q_{A>B}$; see Figure 6	$V_{CC}=4.5\text{V}$	-	-	47	ns
			$V_{CC}=4.5\text{V}$	-	-	47	ns
transition time	t_t	$V_{CC}=4.5\text{V}$; see Figure 6 ^[2]	-	-	22	ns	

Note:

[1] t_{pd} is the same as t_{PLH} and t_{PHL} .

[2] t_t is the same as t_{THL} and t_{TLH} .



4、Testing Circuit

4.1、AC Testing Circuit

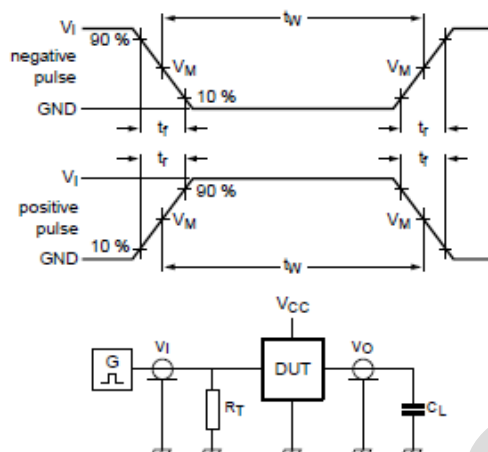

Figure 5. Test circuit for measuring switching times

Definitions for test circuit:

C_L =Load capacitance including jig and probe capacitance.

R_T =Termination resistance should be equal to the output impedance Z_o of the pulse generator.

4.2、AC Testing Waveforms

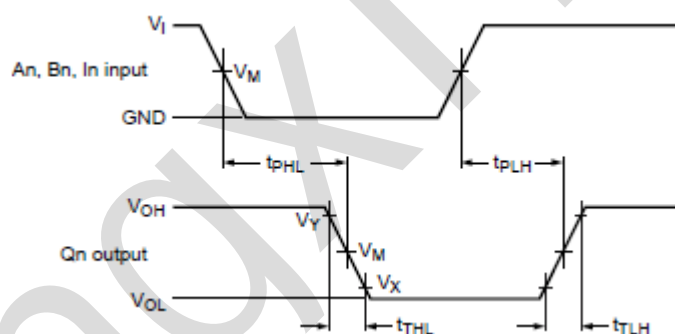

Figure 6. Word A inputs (An), word B inputs (Bn) and expansion inputs (In) to the outputs (Qn) propagation delays and the output transition times

4.3、Measurement Points

Type	Input		Output		
	V_I	V_M	V_M	V_X	V_Y
SN74HC85	V_{CC}	$0.5 \times V_{CC}$	$0.5 \times V_{CC}$	$0.1 \times V_{CC}$	$0.9 \times V_{CC}$
SN74HCT85	3V	1.3V	1.3V	$0.1 \times V_{CC}$	$0.9 \times V_{CC}$

4.4、Test Data

Type	Input		Load	Test
	V_I	t_r, t_f	C_L	
SN74HC85	V_{CC}	6ns	15pF, 50pF	t_{PHL}, t_{PLH}
SN74HCT85	3V	6ns	15pF, 50pF	t_{PHL}, t_{PLH}



5、Package Information

5.1、DIP16

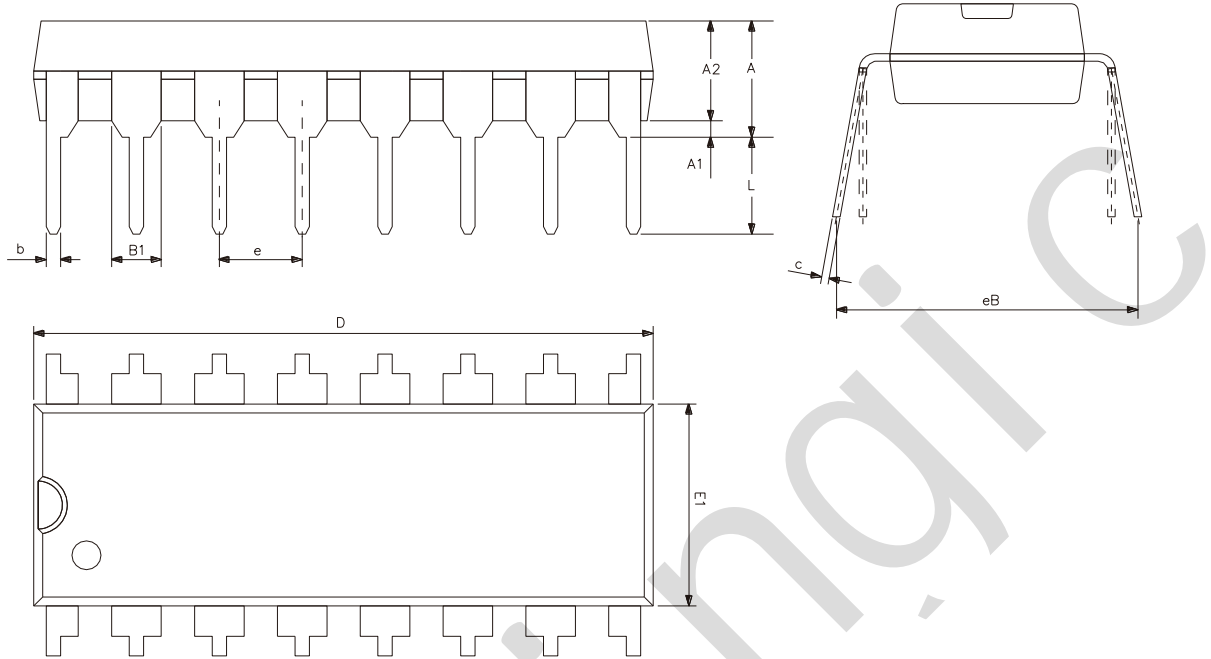

Symbol	Dimensions (mm)	
	Min.	Max.
A2	3.20	3.60
A1	0.51	-
A	3.60	5.33
L	3.00	3.60
b	0.36	0.56
B1	1.52	
D	18.80	19.94
E1	6.20	6.60
e	2.54	
c	0.20	0.36
eB	7.62	9.30



5.2、SOP16

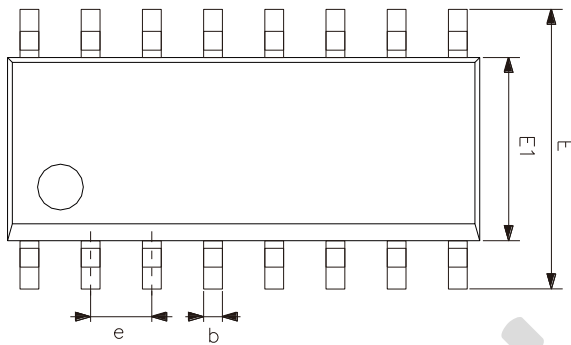
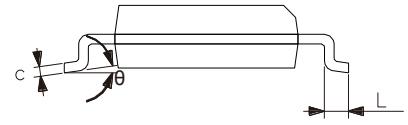
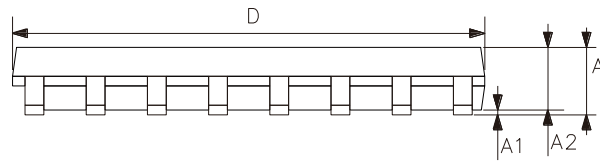

Symbol	Dimensions (mm)	
	Min.	Max.
A	1.35	1.80
A1	0.10	0.25
A2	1.25	1.55
b	0.33	0.51
c	0.19	0.25
D	9.50	10.10
E	5.80	6.30
E1	3.70	4.10
e	1.27	
L	0.35	0.89
θ	0°	8°



5.3、TSSOP16

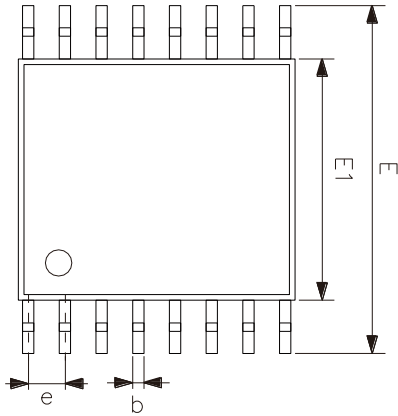
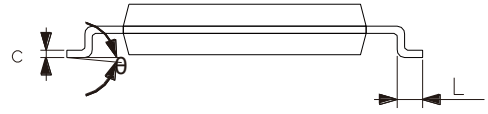
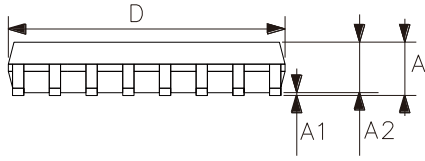

Symbol	Dimensions (mm)	
	Min.	Max.
A	-	1.20
A1	0.05	0.15
A2	0.80	1.05
b	0.19	0.30
c	0.09	0.20
D	4.90	5.10
E1	4.30	4.50
E	6.20	6.60
e	0.65	
L	0.45	0.75
θ	0°	8°



灵星芯微 集成电路

6、 Statements And Notes

6.1、 The name and content of Hazardous substances or Elements in the product

Part name	Hazardous substances or Elements									
	Lead and lead compounds	Mercury and mercury compounds	Cadmium and cadmium compounds	Hexavalent chromium compounds	Polybrominated biphenyls	Polybrominated biphenyl ethers	Dibutyl phthalate	Butylbenzyl phthalate	Di-2-ethylhexyl phthalate	Diisobutyl phthalate
Lead frame	○	○	○	○	○	○	○	○	○	○
Plastic resin	○	○	○	○	○	○	○	○	○	○
Chip	○	○	○	○	○	○	○	○	○	○
The lead	○	○	○	○	○	○	○	○	○	○
Plastic sheet installed	○	○	○	○	○	○	○	○	○	○
explanation	○: Indicates that the content of hazardous substances or elements in the detection limit of the following the SJ/T11363-2006 standard. ×: Indicates that the content of hazardous substances or elements exceeding the SJ/T11363-2006 Standard limit requirements.									

6.2、 Notes

We Recommend you to read this chapter carefully before using this product.

The information in this chapter is provided for reference only and Lingxing disclaims any express or implied warranties, including but not limited to applicability, special application or non-infringement of third party rights.

This product is not suitable for critical equipment such as life-saving, life-sustaining or safety equipment. It is also not suitable for applications that may result in personal injury, death, or serious property or environmental damage due to product malfunction or failure. Lingxing will not be liable for any damages incurred by the customers at their own risk for such applications.

The customer is responsible for conducting all necessary tests Lingxing's application to avoid failure in the application or the application of the customer's third party users. Lingxing does not accept any liability.

The Company reserves the right to change or improve the information published in this chapter at any time. The information in this chapter are subject to change without notice. We recommend the customer to consult our sales staff before purchasing.

Please obtain related materials form Lingxing's regular channels and we are not responsible for its content if it is provided by sources other than our company.

In case of any conflict between the Chinese and English version, the version is subject to the Chinese one.